

General Safety Instructions

Application

Electrical Connection

Installation

Maintenance



Submersible pump for building sites

You have bought a Jung Pumpen product and therefore purchased quality and performance. Guarantee this achievement by an installation according to the operating instructions so that our product can meet your demands to your full satisfaction. Please note that damages as a result of poor installation will affect the guarantee.

For this reason please follow the advice of the operating instructions.

Like any other electrical appliance the operation of this product can fail by electrical failure or technical faults. It is wise to always consider standby pumps, emergency generator and a control unit fitted with mains independent alarm.

UB 62 E	ID-No. 09816 / 03
UB 62 ES	ID-No. 09818 / 03
UB 62 D	ID-No. 09817 / 02
UB 62 DS	ID-No. 09819 / 02
UB 102 E	ID-No. 09282 / 00
UB 102 ES	ID-No. 09283 / 00
UB 102 D	ID-No. 00533 / 08
UB 102 DS	ID-No. 00534 / 08

Operating Instructions

General Safety Instruction

This operation manual gives basic instructions that should be followed carefully during installation, operation and maintenance. It is essential that this manual is carefully read by the responsible personnel/operator before assembly and commissioning. It is always to be kept available at the installation site.

Identification of safety instructions in the operating manual

Safety instructions given in this manual non-available with which would affect safety are identified by the following symbol:



General danger for personnel



Dangerous voltage



Danger for machine and function

It is imperative that signs affixed to the machine, e.g.

- rotation arrow
 - fluid connection symbols
 - data / approval plate
- be observed and kept legible.

Qualification of personnel

An authorized (certified) electrician and mechanic shall carry out all work. Scope of responsibility and supervision of the personnel must be exactly defined by the plant operator. If the staff does not have the necessary knowledge, they must be trained and instructed, which may be performed by the machine manufacturer or supplier on behalf of the plant operator, moreover, the plant operator is to make sure that the contents of the operating manual are fully understood by the personnel.

Hazards in the event of non-compliance with the safety instructions

Non-compliance with the safety instructions may produce a risk to the personnel as well as to the environment and the machine and results in a loss of any right to claim damages or compensation. For example, non-compliance may involve the following hazards:

- Failure of important functions of the machine/plant
- Failure of specified procedures of maintenance and repair
- Exposure of people to electrical, mechanical and chemical hazards
- Endangering the environment owing to hazardous substances being released.

Safety regulations for owner / operator

All safety instructions contained in this manual, all relevant national and local health and safety codes and any other service and safety instructions issued by the plant operator shall be complied with.

Safety instructions relevant for operation

If hot or cold machine components involve hazards, they must be guarded against accidental contact.

Guards for moving parts (e.g. coupling) must not be removed from the machine while in operation.

Any leakage of hazardous (e.g. explosive, toxic, hot) fluids (e.g. from the shaft seal) must be drained away so as to prevent any risk to persons or the environment. Statutory regulations are to be complied with. The pumping station must be kept tidy and in good condition.

Hazards resulting from electricity are to be prevented (see for example, the national-specifications or the regulations of your local electricity supply company.)

Safety instructions relevant for maintenance, inspections and assembly work

It shall be the plant operator's responsibility to ensure that all maintenance, inspection and assembly work is performed by authorized and qualified personnel who have adequately familiarized themselves with the subject matter by studying this manual in detail.

Any work on the machine shall only be performed when it is at a stand-still, it being imperative that the procedure for shutting down the machine described in this manual be followed.

Pumps and pump units which convey hazardous media must be decontaminated. All waste emissions such as used oil must be appropriately disposed of, oil spills must be cleaned up and emissions to the environment must be reported. On completion of work all safety and protective facilities must be reinstalled and made operative again.

Prior to restarting the machine, the instructions listed under "Electrical Connection" and "Installation" are to be observed.

Unauthorized alterations and production of spare parts

Any modification may be made to the machine only after consultation with the manufacturer. Using spare parts and accessories authorised by the manufacturer is in the interest of safety. Use of other parts may exempt the manufacturer from any warranty or compensation claims.

Unauthorized modes of operation

The reliability of the machine delivered will be only guaranteed if it is used in the manner intended, in accordance with clause 1; of this manual: The limit values specified in the data sheet must under no circumstances be exceeded.

Warranty claim

Jung Pumpen pumps are long living, high quality products with expected reliable operation. However, should the need arise for a warranty claim, please contact your Jung Pumpen distributor.

Operating Instructions

List of contents

• General safety instructions.....	page 2
• List of contents.....	page 3
• Technical data	page 4
- Dimensions	
- Application	
- Transportation	
• Safety precautions	page 5
• Installation	page 6
- Electrical connection	
- Sense of rotation	
- Winding thermostat	
- Wiring diagrams	
- Operation through frequency converter	
• Installation	page 7
- Installation with guide rail system	
- Mobile installation	
• Maintenance / Service	page 8 - 9
- Mobile operation	
- Maintenance	
- Checking the seal chamber	
- Oil changing	
- Cleaning	
- Repairs	
- Malfunctions	
• Sectional drawing	page 10
• Spare parts list	page 11
• Declaration of conformity	page 11

Operating Instructions

Technical Data

	UB 62 E	UB 62 ES	UB 102 E	UB 102 ES	UB 62 D	UB 62 DS	UB 102 D	UB 102 DS
Supply voltage [V]	1 x 230				3 x 400			
Power input P1 [kW]	0,83		1,37		0,85		1,36	
Nominal current [A]	3,90		6,00		1,40		2,40	
cos phi	0,94		0,98		0,87		0,84	
r.p.m. [1/min]	2510		2705		2800		2740	
weight [kg]	13,2	13,5	15,0	15,3	13,5	13,8	15,5	15,8
max. switch. frequency	30 / h							
max. water temperature	1 – 40° C							
protective system	IP 68							

Description

This manual applies to a Jung Pumpen submersible drainage pump UB 62 or 102 E/ES or D/DS. „S“ models with mounted on level control.

Picture 1: dimensions

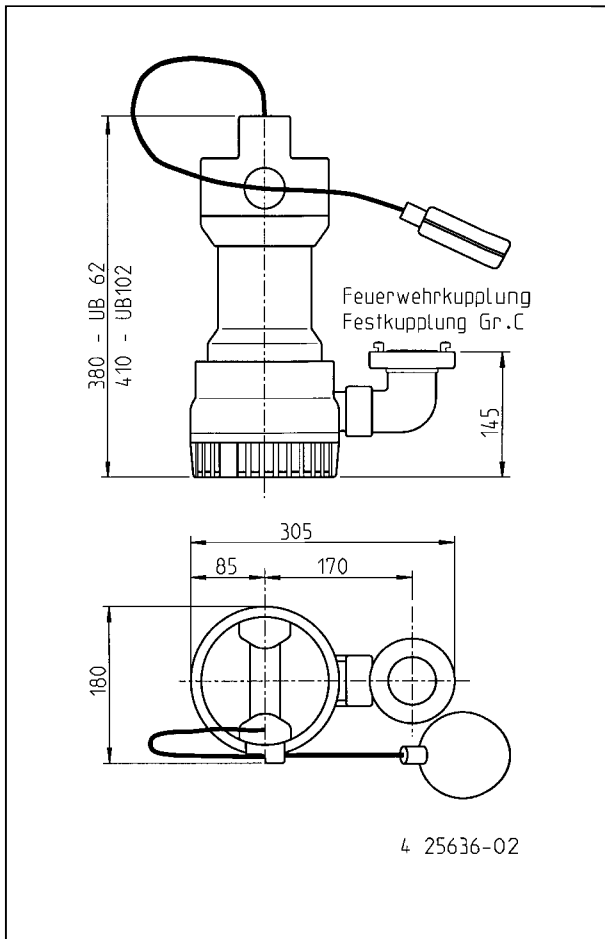

Application

- The pumps of the UB series are designed for de-watering works at building constructions, civil engineering, drainage works or at disaster operations. The pumps are suitable for dirty-, rain-, ground-, and drainage water with solids up to a Ø of 10 mm. They must not be used for pumping sewage water from lavatories.
- Allowed temperature of pumped medium:
Continuous operation : 40 °C (S1-operation)
Intermittent operation : S3-operation 10%,
1 min. operation, 9 min. stand by
- At different operating conditions in explosion hazardous locations please ask the industrial and trade supervision, the building inspection or the employer's liability insurance association.
- If kept dry the pump can be stored down to a minimum temperature of -20°C. The flooded pump must not freeze.
- noise emission: >70 dB (A)

Transportation and storage

The pump can be transported and stored in vertical or horizontal position.



Always use the shackle to carry the pump, never lift it at the cable. Make sure the pump cannot roll or fall over and injure people or damage property.

If kept dry the pump can be stored down to a minimum temperature of -20°C. The flooded pump must not freeze.

For longer periods of storage, the pump must be protected against moisture and heat. The impeller should be rotated occasionally to prevent the seals from sticking together.

After a long period of storage, the pump should be inspected before it is taken into operation. Pay special attention to the seals and the cable gland.

Follow the instructions of „Operation“.

Operating Instructions



Please pay attention to the following regulations at installing the pump(s) or ask your qualified electrician / distributor.

- regulations for electrical installations (in Germany: VDE 0100, VDE 0165)
- regulations for prevention of accidents in sewage technical installations (in Germany: GUV 7.4, GUV 17.6)
- guidelines for explosion protection (in Germany: GUV 19.8)
- electrical installations in explosion hazardous areas (in Germany: Elex V)

Safety precautions

In order to minimize the risk of accidents in connection with the service and installation work, the following rules should be followed:

- Never work alone. Use a lifting harness, safety line and a respirator as required. Do not ignore the risk of drowning.
- Make sure there are no poisonous gases within the work area.
- Check the explosion risk before welding or using electric hand tools.
- Do not ignore health hazards. Observe strict cleanliness.
- Bear in mind the risk of electrical accidents.
- Make sure that the lifting equipment is in good condition.
- Provide a suitable barrier around the work area, e.g. guard rail
- Make sure you have a clear path of retreat.
- Use safety helmet, safety goggles and protective shoes.
- All personnel who work with sewage systems must be vaccinated against diseases to which they may be exposed.
- A first-aid kit must be close at hand.
- Note that special rules apply to installation in explosive atmosphere.

Follow all other health and safety rules and local codes and ordinances

Electrical connection



- Following works should only be done by qualified and authorized electricians.

- Jung Pumpen disclaims all responsibility for work done by untrained or/and unauthorized personnel.



- Heed operating voltage !
(see name plate and additional labels)

- Take out the main fuses to isolate the mains supply from the control unit before repairs or any other works and make sure it cannot be energized again.
- If the pump is equipped with automatic level control, there is a risk of sudden restart.
- Before starting check the efficiency of the protective arrangements of the pump and the monitoring equipment. Failure to heed this warning may cause a lethal accident.
- Do not put the lead ends into water!
Irruption of water may cause malfunctions.

- If persons are likely to come into physical contact with pump or pumped media, the earthed (grounded) socket must have an additional connection to an earth- (ground) fault protection device (GFI).
- When pumping near a lake, a jetty, a pond etc. a safety distance of at least 20 m between the person and the pump is applicable. Do not place the pump directly in a pool. Observe the special safety regulations if used in connection with swimming pools.
- Use the pump only in accordance to the data stated on the pump's plate resp. in the technical data on page 4.



WARNING

Special rules apply to installation in explosive atmosphere.

Intrinsically safe circuits (Exi) are normally required for the automatic level control system by level regulators.

- A Jung Pumpen control unit gives you the certainty of design under safety regulations and an acceptance of work without any problems.
- Level sensors must be used at low voltage. For further details please see data sheet / o.m. Local rules may specify otherwise.
- To prevent the pump from blocking after long rest periods an additional daily trial run unit can be installed.
- Connection only to a mains supply installed in accordance to the local regulations. For fusing use only 10 A slow fuses or automatic circuit-breaker with C or D characteristic. (former G and K)
- Because the motor's nominal voltage is measured at the terminal board of the pump, please consider the voltage drop of long supply cables.
- The motors of the three-phase a.c. pumps must be protected by a suitable overcurrent release. Adjustment as following:
direct start: + 10% of the nominal current
star-delta start: (nominal current x 0,58) + 10 %
If the protective arrangement has triggered, eliminate the trouble
- Replace the cable if the cable jacket is damaged. Do not pinch the cable or pull it around sharp bends.
- Always install the control unit in a dry and well ventilated room above the backpressure level. Never install the control unit in the sump !

Earthing

For safety reasons, the earth conductor should be appr. 50 mm (2 inch) longer than the phase conductors. If the motor cable is jerked loose by mistake, the earth conductor should be at last conductor to come loose from its terminal. This applies to both ends of cable. Ensure the correct earthing of the pump and the control unit.

Operating Instructions

Picture 2: wiring E / ES

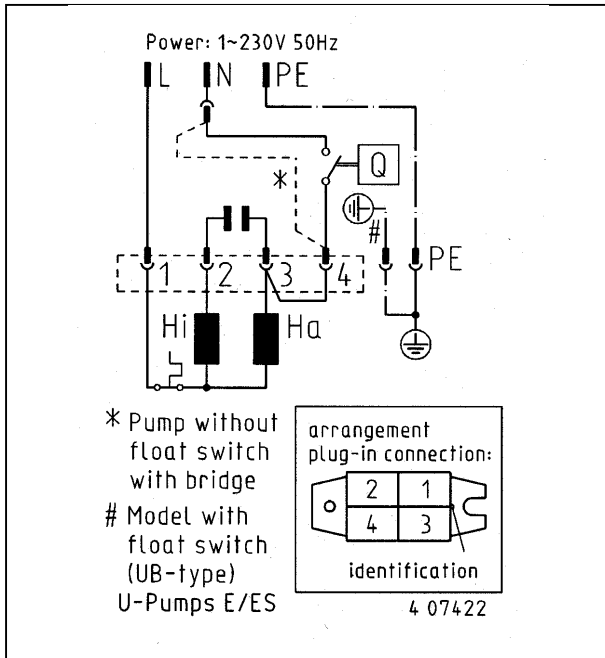

Picture 3: wiring D / DS

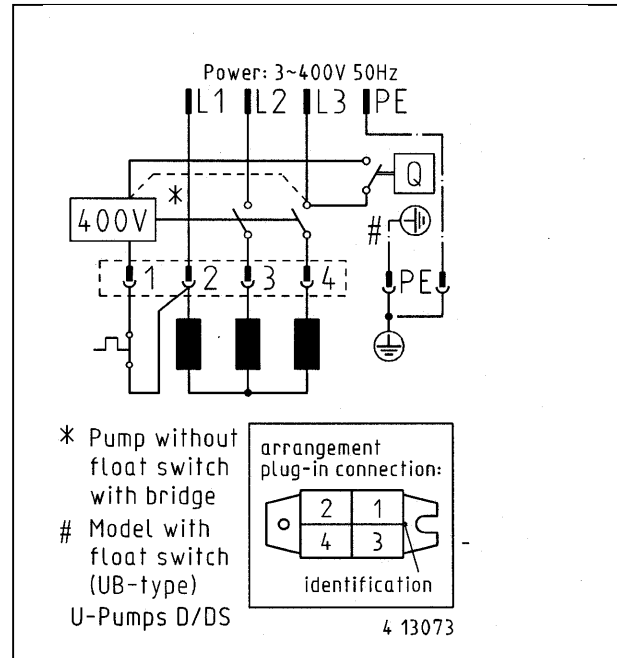

Winding thermostat

Because of the built-in thermostat an additional motor protection is not necessary. Inadmissible high temperatures and operation times will release the thermostat. If so, pull out the plug before repairs to prevent automatically pump restarts.

Sense of rotation (only three-phase models)

Before installation you have to check the sense of rotation. At correct rotating field the start bump of the pump is into the opposite direction to the arrow on the top of the pump. In case of wrong direction of rotation change two of the three phases of the mains supply.



Watch out for the start bump, which can be powerful

Operation through frequency converter

WARNING If you want to operate pumps through a frequency converter please contact your distributor !

If the technical feasibility is already checked, the pumps have to be ordered as a special version !

They need a special PTC thermistor for motor protection and a tripping unit with a conformity certificate ! (e.g. PTB 3.53 – PTC/A)

Use frequency converters only for deceleration !

If three-phase current pumps are operated through a frequency converter, the r.p.m. change proportional to the input-frequency.

Frequency converters have a setting range between nearly 0 Hz and more than 50 Hz. Because of physically reasons the pumps must not be operated with higher frequencies than indicated on the name plate. If the frequency rises beyond the rated value, the absorbed power escalates to the overload of the motor.

To recognize pumps with a PTC thermistor, please check the name plate. The last letter in the field of the motor type must be a **K**.

Example: motor type: D 160-4/200 K has a PTC thermistor and can be operated through a frequency converter. Pumps without this mark cannot be operated through a frequency converter.

Example: motor type: D 112-4/200

Additionally the pumps have a label at the lead end to point out the possible frequency converter operation.

Supply voltage of the PTC thermistor: max. 2,5 V !

Installation

To ensure the proper installation, consider the dimensions of the installation. The sump has to be cleaned from all sediments before any installation or repair works. The minimum height between the lifting hook and the floor shall be sufficient to lift the pump out of the sump. The lifting equipment shall be able to hoist the pump straight up and down in the sump, preferably without the need for resetting the lifting hook. Oversized lifting equipment could cause damages if the pump should stick when it is lifted.

The lifting equipment has to be securely anchored.

Operating Instructions

Picture 4: installation example

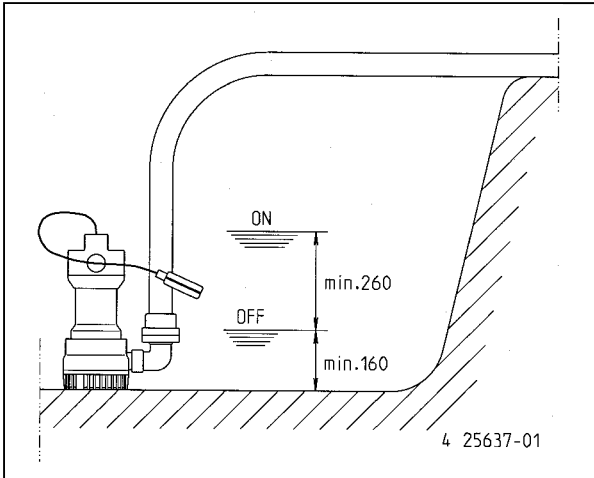

Always use the shackle to carry the pump, never lift it at the cable or the hose!

WARNING To lower the pump in a deep tank, use a rope or a chain.

Stay clear of suspended loads.

Take out the main fuses to isolate the mains supply both control unit and pump before any works and make sure it cannot be energized again.

Make sure the pump cannot roll or fall over and injure people or damage property.

In some installations the water and the pump can be hot. Bear in mind the risk of burn injuries.

Before installation, please check:

- the visible parts of the pump and the installation
- sluice and reflux valves
- the oil level in the oil chamber
- if the impeller moves freely
- direction of rotation

The pump should be installed accordingly to the examples in picture 4 and 5. Observe the min. flow speed of 0,7 m/s in the pipe work.

The pump must be secured against sinking into the bottom of the excavation, if necessary, by a suitable base or support. For this application we recommend our transport / protection cage.

If the pump is used in the cage, the cable of the submersible ball contact switch must be adjusted from 250 mm to a length of 100 mm, to guarantee the trouble-free operation.

At changing the operational site ensure a completely drained off hose when the pump stops working. When the pump operates again, water in the hose will prevent the deaeration of the spiral housing and therewith the correct operation of the pump. For the same reason the pump may not operate properly when it is submerged in switched on condition.

If the pump is used in sumps that can dry out, it is also possible to deaerate the spiral housing by taking the hexagon socket screw M8x16 [Pos. 25] out of the spiral housing.

Picture 5: installation example with cage

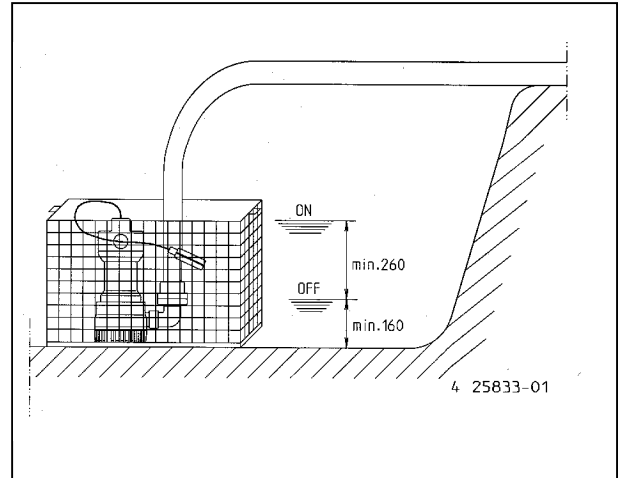

WARNING Observe the measurements of the level sensors as shown in picture 3 and 4. The sensor must not be installed below the inlet.

Mobile operation / deaeration

For mobile operation and retrofitting of existing sumps a pump base installation is uncomplicated and easy to maintain. Mount a 90° elbow to the discharge, install the pressure pipe, fasten the chain at the shackle and lower the pump into the excavation. A fastening device for a hoist simplifies the pump installation.

At changing the operational site ensure a completely drained off hose when the pump stops working. When the pump operates again, water in the hose will prevent the deaeration of the spiral housing and therewith the correct operation of the pump. For the same reason the pump may not operate properly when it is submerged in switched on condition.

WARNING In case of a damage at the pump a slight quantity of the oil chamber filling can leak into the pumping medium.

Operating Instructions

Maintenance



Take out the main fuses to isolate the mains supply of both, control unit and pump, before any works and make sure it cannot be energized again. Check the cable on mechanical or chemical damages.



At using a chain to lift the pump, please pay attention to the rules for prevention of accidents. Chains have to be inspected regularly by qualified personal.



The motor of the UFK series has the protection type: flameproof enclosure. Only authorized workshops or the manufacturer are permitted to carry out repairs effecting the flameproof ness. In case of repairs the gap peripheries have to be inspected for damages, defective parts must be replaced by genuine spare parts. Jung Pumpen disclaims all responsibility for work done by untrained, unauthorized personnel.

General safety

- clean the pump thoroughly
- beware of the risk of infection
- follow local safety regulations

The pump is designed for use in liquids which can be dangerous to health. When working on the pump, prevent injuries to the eyes and skin, by:

- wearing goggles and rubber gloves
- cleaning the pump before any works
- cleaning the parts after dismantling
- hold a cloth over the drain plug to prevent splatter when opening the oil chamber

In case of contact with dangerous liquids:

- eye contact: rinse your eyes immediately in running water for 15 min. Hold your eyelids apart with your fingers. Contact an eye specialist
- skin contact: remove contaminated clothes, wash your skin with soap and water, seek medical attention, if necessary

To keep the reliability of operation the first oil change of the seal chamber should be made after 300 working hours (max. 6 months), after that the oil should be changed every 1000 working hours, not later than once a year.

If the pump delivers water with abrasive additions servicing should be carried out at adequate shorter intervals. At decreasing flow rates or ascending noises the impeller has to be checked on wear, and if necessary, it has to be changed.

Checking the seal chamber

The seal chamber has a filling- and drain plug with hexagon head (width across 13 mm). To check the mechanical seal put the pump into a horizontal position and drain the oil into a clean graduated measuring can. If the quantity of oil corresponds to the oil originally in place and is not discoloured (milky) the primary mechanical seal is in good condition.

Milky or yellowish/grey oil indicates that water has leaked into the oil chamber. In this case the oil filling should be renewed and inspected again after a further 300 hours. If the oil is again found to be discoloured or infiltrated by dirty particles the mechanical seal should be checked for wear and replaced if necessary. For automatically monitoring of the seal chamber, the filling plug can be replaced by our seal leak detector DKG (Code-No. 00252) or DKG-Ex (Code-No. 00249).

Oil changing

For the change of the oil, use spindle oil make: „ESSO“, type: Spinesso 22 or other mineral oils with a viscosity of 22 – 46, quantity: see spare parts list.

WARNING Do not overfill the seal chamber, otherwise the pump can seriously be damaged.

Changing the impeller

1. Take the 3 hexagon socket screws [18] out of strainer base [15] and remove it together with the cover [19].
2. Take the hexagon socket screw [17] together with the distance bush [16] out of impeller [13] and remove it.

WARNING When the impeller is removed from the shaft, make sure you do not lose parts of the mechanical seal.

3. Push the new impeller [13] on the shaft up to the limit stop and secure it with the hexagon socket screw [17] and the distance bush [16].
4. Clean the O-ring [20] thoroughly, push the cover [19] with the strainer base [15] into position and fasten it with the screws [18].

Changing the mechanical seal

1. Take off the impeller as described above.
2. Take out the mechanical seal [14] with a small flat screwdriver. Clean the receiver thoroughly and push in the new mechanical seal [14].
3. Assemble the impeller as described under “changing the impeller.”

Operating Instructions

Cleaning

The foot strainer prevents coarse impurities and fibres from reaching the impeller. Regularly cleaning secures the maximum pumping capacity.

To clean the impeller and the spiral housing, unscrew the 3 hexagon socket screws at the bottom side of the pump and take off the foot strainer.

To clean the impeller remove the cover as well.

Regularly cleaning of the impeller and the level control sensors or float switches secures the maximum pumping capacity and operational reliability.

for UAK series

Jung Pumpen GmbH & Co Industriestraße 4-6 - 33803 Steinhagen XX ¹
Hebewirkung – siehe technische Daten Geräuschemissionswert < 70dB (A) Korrosionsschutz – Kunstharzlack

¹ Die beiden ersten Ziffern der Pumpen-Nr. bezeichnen das Produktionsjahr.

Torque ratio M_A for screw material:

for M 6, $M_A = 8 \text{ Nm (0.8 kpm)}$

for M 8, $M_A = 20 \text{ Nm (2.0 kpm)}$

for M 10, $M_A = 40 \text{ Nm (4.0 kpm)}$

Malfunctions

Pump does not run

cause: missing mains supply

remedy: check supply voltage

cause: faulty fuse (maybe too low)

remedy: check fuse and change if necessary

cause: damaged supply cable

remedy: changing of the cable gland only by qualified personnel

Pump runs, but doesn't deliver water

cause: trapped air in the spiral housing

remedy: drain off the pressure tube or hose, to ensure the opening of the reflux valve to deaerate the spiral housing and ensure the correct operation of the pump

Blockage of impeller

cause: solid- or fibrous admixtures blocking the impeller

remedy: check impeller and spiral housing, as explained under „cleaning“

Reduced performance curve

cause: worn-out impeller

remedy: change impeller

cause: wrong sense of rotation

remedy: change two of the three leads inside of the plug

Operating Instructions

Picture 6: sectional drawing

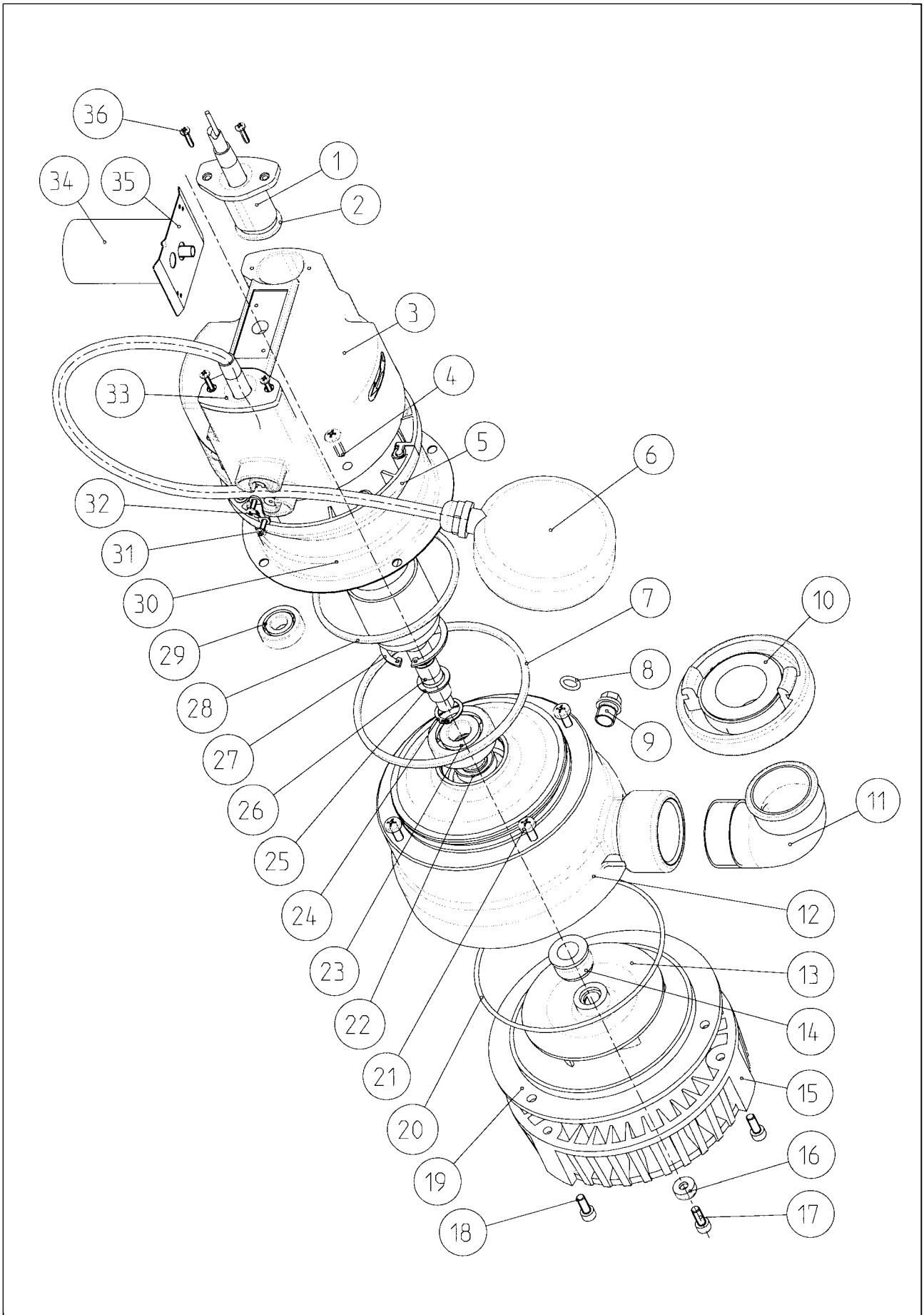

Operating Instructions

Position	Code-No.	Description	Qty. E	Qty ES	Qty. D	Qty. DS
1	25343	cable gland, completely, 10,0 m	1	1	-	-
1	25345	cable gland, completely, 10,0 m	-	-	1	1
2	25352	O-ring 25 x 4	2	2	2	2
3	24926	terminal cover without float switch	1	1	1	1
4	25388	oval head screw 6,0 x 20	4	4	4	4
5	25301	hood fastener	2	2	2	2
6	25351	submersible ball contact switch ES		1		
6	25550	submersible ball contact switch DS				1
7	19706	O-ring 120,7 x 5,33	1	1	1	1
8	03269	O-ring 10 x 2,5	1	1	1	1
9	03280	plug ¼"	1	1	1	1
10	11892	solid fire hose coupling 1 ½"	1	1	1	1
11	17894	elbow A4, 1 ½"	1	1	1	1
12	25468	Pump casing with separating sheet				
13	23856	impeller, US 62	1	1	1	1
13	25153	impeller, US 102	1	1	1	1
14	12811	mechanical seal, 16 x 18,8	1	1	1	1
15	25135	foot strainer	1	1	1	1
16	23774	cap 18 x 6	1	1	1	1
17	19724	hexagon socket screw with TUFLOK, M6 x 16	1	1	1	1
18	19724	hexagon socket screw with TUFLOK, M6 x 16	3	3	3	3
19	25140	cover for pump casing	1	1	1	1
20	23898	O-ring, 135 x 3	1	1	1	1
21	16367	oval head screw M 6 x 16	4	4	4	4
22	03349	rotary shaft seal 16 x 30 x 7, BA DUO	1	1	1	1
23	05706	deep groove ball bearing 6303 2 ZR	1	1	1	1
24	03285	circlip for shaft, A 17x1,0	1	1	1	1
25	17861	supporting ring 17 x 24 x 1,5	1	1	1	1
26	25356	shaft with rotor E71-2/50, US 62	1	1	-	-
26	25358	shaft with rotor D71-2/50, US 102	-	-	1	1
26	25359	shaft with rotor E71-2/80, US 62	1	1	-	-
26	25361	shaft with rotor D71-2/50, US 102	-	-	1	1
27	00098	circlip for bores J 47 x 1,75	1	1	1	1
28	25389	O-ring 100 x 5	1	1	1	1
29	27432	deep groove ball bearing 6201	1	1	1	1
30	25338	stator casing with motor, US 62	1	1	-	-
30	25339	stator casing with motor, US 102	1	1	-	-
30	25340	stator casing with motor, US 62	-	-	1	1
30	25341	stator casing with motor, US 102	-	-	1	1
31	17312	oval head screw M 3,5 x 16		2		2
32	25353	cable clip		1		1
33	24928	switch cartridge	1	-	1	-
34	19773	capacitor 8 µF, UB 62	1	1	-	-
34	24912	capacitor 20 µF, UB 102	1	1	-	-
34	13132	contactor 380 V SP	-	-	1	1
35	10046	sheet steel retainer	1	1	1	1
36	29037	retainer with top hat rail			1	1
36	20537	oval head screw 3,5 x 16	4	4	4	4
37	13133	oil, Spinesso 22, 300 cm³	1	1	1	1

Replacement kits

14999	oil, Spinesso 22, 1 Liter bottle
25468	Spiral housing, consisting of: 17894, 25337
25629	Seal kit, consisting of: 03269, 03349, 03990, 12811, 19706, 23898, 25352, 25389

By ordering spare parts indicate type of the pump and the part number.

Operating Instructions

JUNG PUMPEN GmbH & Co KG Tel. 05204 17 - 0
Industriestr. 4-6 Fax 05204 80368
33803 Steinhagen, Germany e-Mail info@jung-pumpen.de



EG - Konformitätserklärung Declaration of EC - Conformity Attestation de Conformité CE

Hiermit erklären wir, daß alle Exemplare unserer Geräte
Herewith we declare that all our devices
Nous attestons par la présente, que tous nos produits

U3K...	UAK... (bis 3,2kW)	US ... (außer ...Ex)
U6K...	J67...	UB ...

den wesentlichen Schutzanforderungen folgender EG – Richtlinien entsprechen :
comply with the following provisions applying to :
correspondent aux principales directives CE suivantes :

EG - Niederspannungsrichtlinie	73/23/EWG i.d.F. 93/68/EWG
EG - EMV Richtlinie	89/336/EWG
EG - Bauproduktenrichtlinie	89/106/EWG

Angewendete harmonisierte Normen, insbesondere :
Applied harmonized standards in particular :
Principales normes harmonisées :

73/23/EWG	89/336/EWG	89/106/EWG
EN 60 335 - 1	EN 55 014 - 1/2	EN 12050 - 2
EN 60 335 - 2 - 41	EN 61 000 - 3 - 2/3	
EN 60 034 - T5		

Angewendete, nicht unter obige EG Richtlinien fallende technische Normen und Spezifikationen :
Applied national technical standards and specifications in particular :
Normes et spécifications n'entrant pas dans les directives ci-dessus :

EN 809	VDE-Ausweis Nr. 93172 G (U3K...)
EN 292 Teil 1+ 2	VDE-Ausweis Nr. 70808 G (U6K...)
	VDE-Ausweis Nr. 135569 G (US+UB...)

Bei einer nicht mit uns abgestimmten Änderung des Gerätes verliert diese Erklärung ihre Gültigkeit.
By altering the device without approval the declaration would invalidate.
Toute modification de la machine, effectuée sans notre accord, annule la validité de la présente déclaration.

Steinhagen, den 23.06.2003

(Schweitzer)
Geschäftsführer

(Abel)
Techn.Geschäftsleitung

40010241.DOC / TB – Sn
Ersetzt dito. vom 14.01.03