General Safety Instructions

Application

Electrical Connection

Installation

Maintenance



Sewage disposal unit

You have bought a Jung Pumpen product and therefore purchased quality and performance. Guarantee this achievement by an installation according to the operating instructions so that our product can meet your demands to your full satisfaction. Please note that damages as a result of poor installation will affect the guarantee.

For this reason please follow the advice of the operating instructions.

Like any other electrical appliance the operation of this product can fail by electrical failure or technical faults. It is wise to always consider standby pumps, emergency generator and a control unit fitted with mains independent alarm.

compli 1010/4 BWE	ID-No. 09273 / 00
compli 1010/4 BW	ID-No. 09829 / 03
compli 1015/4 BW	ID-No. 09830 / 03
compli 1025/4 BW	ID-No. 09831 / 03

compli 1010/4 BW SE	ID-No. 09274 / 00
compli 1010/4 BW S	ID-No. 09838 / 03
compli 1015/4 BW S	ID-No. 09839 / 03
compli 1025/4 BW S	ID-No. 09840 / 03

Operating Instructions

General Safety Instruction

This operation manual gives basic instructions that should be followed carefully during installation, operation and maintenance. It is essential that this manual is carefully read by the responsible personnel/operator before assembly and commissioning. It is always to be kept available at the installation site.

Identification of safety instructions in the operating manual

Safety instructions given in this manual non-available with which would affect safety are identified by the following symbol:



General danger for personnel



Dangerous voltage



Danger for machine and function

It is imperative that signs affixed to the machine, e.g.

- rotation arrow
- fluid connection symbols
- data / approval plate

be observed and kept legible.

Qualification of personnel

An authorized (certified) electrician and mechanic shall carry out all work. Scope of responsibility and supervision of the personnel must be exactly defined by the plant operator. If the staff does not have the necessary knowledge, they must be trained and instructed, which may be performed by the machine manufacturer or supplier on behalf of the plant operator, moreover, the plant operator is to make sure that the contents of the operating manual are fully understood by the personnel.

Hazards in the event of non-compliance with the safety instructions

Non-compliance with the safety instructions may produce a risk to the personnel as well as to the environment and the machine and results in a loss of any right to claim damages or compensation. For example, non-compliance may involve the following hazards:

- Failure of important functions of the machine/plant
- Failure of specified procedures of maintenance and repair
- Exposure of people to electrical, mechanical and chemical hazards
- Endangering the environment owing to hazardous substances being released.

Safety regulations for owner / operator

All safety instructions contained in this manual, all relevant national and local health and safety codes and any other service and safety instructions issued by the plant operator shall be complied with.

Safety instructions relevant for operation

If hot or cold machine components involve hazards, they must be guarded against accidental contact.

Guards for moving parts (e.g. coupling) must not be removed from the machine while in operation.

Any leakage of hazardous (e.g. explosive, toxic, hot) fluids (e.g. from the shaft seal) must be drained away so as to prevent any risk to persons or the environment. Statutory regulations are to be complied with. The pumping station must be kept tidy and in good condition.

Hazards resulting from electricity are to be prevented (see for example, the national-specifications or the regulations of your local electricity supply company.)

Safety instructions relevant for maintenance, inspections and assembly work

It shall be the plant operator's responsibility to ensure that all maintenance, inspection and assembly work is performed by authorized and qualified personnel who have adequately familiarized themselves with the subject matter by studying this manual in detail.

Any work on the machine shall only be performed when it is at a stand-still, it being imperative that the procedure for shutting down the machine described in this manual be followed.

Pumps and pump units which convey hazardous media must be decontaminated. All waste emissions such as used oil must be appropriately disposed of, oil spills must be cleaned up and emissions to the environment must be reported. On completion of work all safety and protective facilities must be reinstalled and made operative again.

Prior to restarting the machine, the instructions listed under "Electrical Connection" and "Installation" are to be observed.

Unauthorized alterations and production of spare parts

Any modification may be made to the machine only after consultation with the manufacturer. Using spare parts and accessories authorised by the manufacturer is in the interest of safety. Use of other parts may exempt the manufacturer from any warranty or compensation claims.

Unauthorized modes of operation

The reliability of the machine delivered will be only guaranteed if it is used in the manner intended, in accordance with clause 1; of this manual: The limit values specified in the data sheet must under no circumstances be exceeded.

Warranty claim

Jung Pumpen pumps are long living, high quality products with expected reliable operation. However, should the need arise for a warranty claim, please contact your Jung Pumpen distributor.

Operating Instructions

List of contents

- General safety instructions..... page 2

- List of contents..... page 3

- Technical data page 4
 - Description
 - Application
 - Transportation and storage

- General safety page 5

- Installation / Operation / Maintenance page 6 - 9
 - Mounting
 - Mounting of hand diaphragm pump
 - Control panel
 - Alarm device
 - Malfunctions

- Drawing and spare parts list page 10 - 11

Operating Instructions

Technical Data

	compli			
	1010/4 BW E	1010/4 BW	1015/4 BW	1025/4 BW
Supply voltage [V]	1N ~ 230	3N ~ 400		
Power input P1 [kW]	1,55	1,30	2,2	3,00
Nominal current [A]	6,9	4,9 / 2,8	6,9 / 3,9	8,9 / 5,1
cos phi	0,96	0,68	0,82	0,85
r.p.m. [1/min]	1442	1451	1405	1363
weight [kg]	25	25	25	25
Mode of operation: intermittent service S3	25 %	40 %	35 %	10 %
max. switch. frequency	40 / h			
max. water temperature	1 – 40° C			
protective system	IP 68			

Description

This manual applies to a Jung Pumpen sewage disposal unit of the compli series 1000. Observe the special handling instructions of the Ex-approved UFK type (option)

Picture 1: dimensions

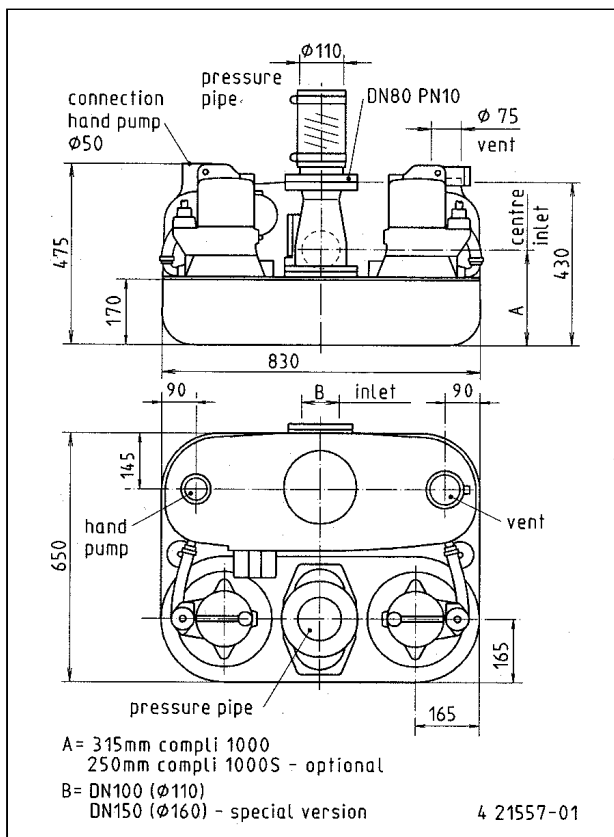

Application

- The compli units are designed for sewage in the domestic, industrial and municipal sectors (DIN EN 12050-1, DIN 1986, part 3). They are ideally suited to deliver sewage and waste water with the usual admixtures to the next gravity sewer in remote situations. In some countries sumps with a connection to the public sewer are an explosion hazardous location. For this application the **explosion proof UFK type** is necessary, for further information ask your distributor.

- Only Ex-approved pumps may be used at different operating conditions in explosion hazardous locations. Please ask the industrial and trade supervision, the building inspection or the employer's liability insurance association for such an application.
- The unit is flood-proof, but the control unit, protective system IP 44, has to be installed in a well-ventilated and dry area, safe from flooding. A high degree of humidity could damage the unit.
- Height of overflow: max. 2 m (3,2 feet), duration: max. 7 days
- Allowed temperature of pumped medium:
Continuous operation : 40 °C (S1-operation)
Intermittent operation : S3 operation, 30 % (3,0 min. operation, 7,0 min. stand by)
- If kept dry the pump can be stored down to a minimum temperature of -20°C. The flooded pump must not freeze.
- noise emission: >70 dB (A)

Transportation and storage

The pump can be transported and stored in vertical or horizontal position.



Always use the shackle to carry the pump, never lift it at the cable. Make sure the pump cannot roll or fall over and injure people or damage property.

If kept dry the pump can be stored down to a minimum temperature of -20°C. The flooded pump must not freeze.

For longer periods of storage, the pump must be protected against moisture and heat. The impeller should be rotated occasionally to prevent the seals from sticking together.

After a long period of storage, the pump should be inspected before it is taken into operation. Pay special attention to the seals and the cable gland. Follow the instructions of „Operation“.

Operating Instructions



Please pay attention to the following regulations at installing the pump(s) or ask your qualified electrician / distributor.

- regulations for electrical installations (in Germany: VDE 0100, VDE 0165)
- regulations for prevention of accidents in sewage technical installations (in Germany: GUV 7.4, GUV 17.6)
- guidelines for explosion protection (in Germany: GUV 19.8)
- electrical installations in explosion hazardous areas (in Germany: Elex V)

Safety precautions

In order to minimize the risk of accidents in connection with the service and installation work, the following rules should be followed:

- Never work alone. Use a lifting harness, safety line and a respirator as required. Do not ignore the risk of drowning.
- Make sure there are no poisonous gases within the work area.
- Check the explosion risk before welding or using electric hand tools.
- Do not ignore health hazards. Observe strict cleanliness.
- Bear in mind the risk of electrical accidents.
- Make sure that the lifting equipment is in good condition.
- Provide a suitable barrier around the work area, e.g. guard rail
- Make sure you have a clear path of retreat.
- Use safety helmet, safety goggles and protective shoes.
- All personnel who work with sewage systems must be vaccinated against diseases to which they may be exposed.
- A first-aid kit must be close at hand.
- Note that special rules apply to installation in explosive atmosphere.

Follow all other health and safety rules and local codes and ordinances

Electrical connection



- Following works should only be done by qualified and authorized electricians.



- Jung Pumpen disclaims all responsibility for work done by untrained or/and unauthorized personnel.

- Heed operating voltage !
(see name plate and additional labels)

- Take out the main fuses to isolate the mains supply from the control unit before repairs or any other works and make sure it cannot be energized again.
- If the pump is equipped with automatic level control, there is a risk of sudden restart.
- Before starting check the efficiency of the protective arrangements of the pump and the monitoring equipment. Failure to heed this warning may cause a lethal accident.
- Do not put the lead ends into water!
Irruption of water may cause malfunctions.

- If persons are likely to come into physical contact with pump or pumped media, the earthed (grounded) socket must have an additional connection to an earth- (ground) fault protection device (GFI).
- When pumping near a lake, a jetty, a pond etc. a safety distance of at least 20 m between the person and the pump is applicable. Do not place the pump directly in a pool. Observe the special safety regulations if used in connection with swimming pools.
- Use the pump only in accordance to the data stated on the pump's plate resp. in the technical data on page 4.



WARNING

Special rules apply to installation in explosive atmosphere.

Intrinsically safe circuits (Exi) are normally required for the automatic level control system by level regulators.

- A Jung Pumpen control unit gives you the certainty of design under safety regulations and an acceptance of work without any problems.
- Level sensors must be used at low voltage. For further details please see data sheet / o.m. Local rules may specify otherwise.
- To prevent the pump from blocking after long rest periods an additional daily trial run unit can be installed.
- Connection only to a 2-pole shock proof connector socket or a 16 A 5-pole CEE connector socket, installed in accordance to the local regulations.
- The mains supply must be installed in accordance to the local regulations. For fusing of d.o.l. starting pumps use only 10 A slow fuses or automatic circuit-breaker with C or D characteristic. (former G and K)
Because the motor's nominal voltage is measured at the terminal board of the pump, please consider the voltage drop of long supply cables.
- The motors of the three-phase a.c. pumps must be protected by a suitable overcurrent release.
Adjustment as following:
direct start: + 10% of the nominal current
star-delta start: (nominal current x 0,58) + 10 %
If the protective arrangement has triggered, eliminate the trouble
- Replace the cable if the cable jacket is damaged. Do not pinch the cable or pull it around sharp bends.
- Always install the control unit in a dry and well ventilated room above the backpressure level. Never install the control unit in the sump !

Earthing

For safety reasons, the earth conductor should be appr. 50 mm (2 inch) longer than the phase conductors. If the motor cable is jerked loose by mistake, the earth conductor should be at last conductor to come loose from it's terminal. This applies to both ends of cable. Ensure the correct earthing of the pump and the control unit.

Operating Instructions

Picture 2: installation example

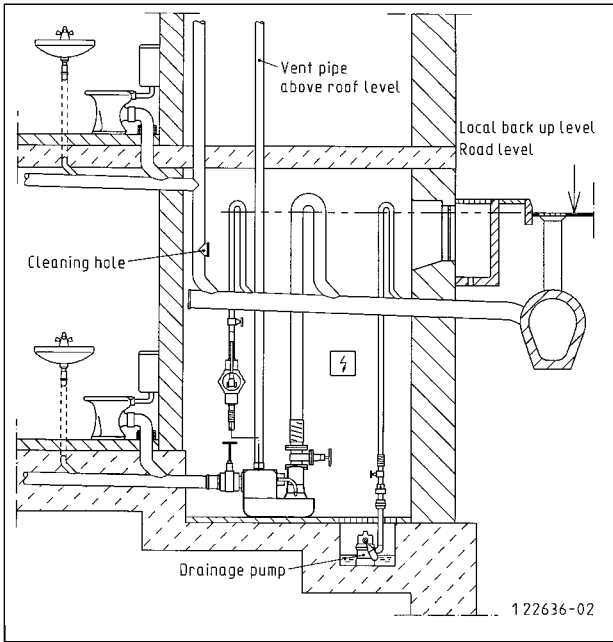

Installation

To ensure the proper installation, consider the dimensions of the installation. The tank has to be cleaned from all sediments before any installation or repair works. The minimum height between the lifting hook and the floor shall be sufficient to lift the pump out of the sump. The lifting equipment shall be able to hoist the pump straight up and down on the tank, preferably without the need for resetting the lifting hook. Oversized lifting equipment could cause damages if the pump should stick when it is lifted.

The lifting equipment has to be securely anchored.

In accordance to the regulations for prevention of accidents and the DIN 12056-2 sewage disposal units must be installed buoyancy proof and with a necessary clearance zone to ensure easy maintenance and repairs at all parts be in consideration.

The min. clearance zone must be 60 cm (2 feet) in breadth and height. The unit should be installed correspondingly to picture 2. Under DIN EN 12056-2 the pressure tube must be taken in a loop over the local back-up level and secured with a DIN EN 12050-4 approved reflux valve. Observe the min. flow speed of 0,7 m/s in the pipework. A sluice valve must be installed in the inlet pipe and behind the reflux valve of the pressure tube. To dewater the operational premise a pump sump with a drainage pump should be planned.



Always use the shackle to carry the pump, never lift it at the cable or the hose !
To lower the pump in a deep tank, use a rope or a chain.

WARNING

Stay clear of suspended loads.

Take out the main fuses to isolate the mains supply both control unit and pump before any works and make sure it cannot be energized again.

Make sure the pump cannot roll or fall over and injure people or damage property.

In some installations the water and the pump can be hot. Bear in mind the risk of burn injuries.

Picture 3: floor mounting

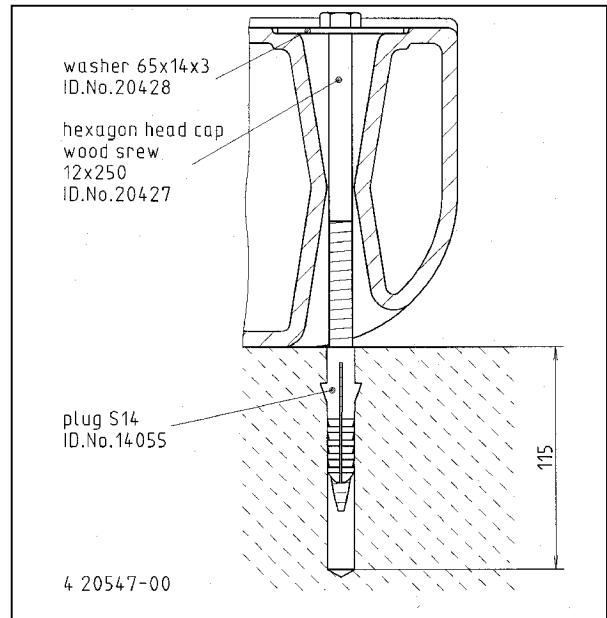

WARNING

All screws that fasten parts on the tank, must not be screwed down with a tightening moment higher than 6 Nm.

Before installation, please check:

- the visible parts of the pump and the installation
- sluice and reflux valves
- the oil level in the oil chamber
- if the impeller moves freely
- direction of rotation

Mounting

1. Push the unit with the clamping joint on the inlet pipe up the limit stop. Close the sluice valve to prevent the water intake during the installation.
2. Tighten the 4 hexagon head cap screws (width across 13 mm) of the inlet clamping joint.
3. Mark and drill the holes for the floor fixing of the tank.
4. Put the washers \varnothing 65 mm on the hexagon head wood screws 12 x 250 mm, screw the S 14 plugs slightly onto the screws and insert everything through the holes in the tank and screw it down.
5. Cut off the upper right connecting branch at the marked position, to open the ventilation and remove the burr. (see pict. 1)
6. Connect the ventilation pipe DN 70 with the elastic connector.
7. Install on the duplex swing type check valve: a: stop valve (accessory) b: spigot flange (included)
8. Connect the pressure pipe with the elastic connection.
- 9.

WARNING

Secure the storage tank from unintended water intake during the installation, e.g. by closing the sluice valve.

Operating Instructions

Mounting of hand diaphragm pump

1. Cut with a sharp knife through the groove of the upper left connecting branch. Use a screwdriver and a hammer to take out the sealing cap and remove the burr. (see pict. 1)
2. Insert the plug-in seal 58/50 (code-No. 10907).
3. Push a PVC pipe, outside Ø 50 mm, through the seal into the tank. The distance between the pipe end and the tank bottom must be min. 30 mm (1,2 inch).
4. Install the hand diaphragm pump on the wall in an easily accessible location and connect it to the PVC pipe.
5. Connect the discharge pipe to the pump in accordance to pict. 4.

Control panel



Install the control panel in a well-ventilated and dry area, safe from flooding. A high degree of humidity could damage the unit.

- The panel should be mounted at a place higher than the backpressure level and should be easily accessible to facilitate checking in case of trouble.
- Take out the main fuses to isolate the mains supply of both, control unit and pump, before any works and make sure it cannot be energized again. Jung Pumpen disclaims all responsibility for work done by untrained, unauthorized personnel
- Check the cable on mechanical or chemical damages.
- Before starting check the efficiency of the protective arrangements of the pump and the monitoring equipment. Failure to heed this warning may cause a lethal accident.

Alarm device

If the control unit is installed in a place where the alarm buzzer is hard to hear, an external flash light or buzzer can be installed. The max. cable length can be 250 m (273 yard) with a minimum core size of 0,75 mm². (see operating instructions of control unit)

Test run

1. Screw off the cleansing hole cover from the tank.
2. Open the inlet and outlet sluice valves.
3. Connect the mains supply. Check the sense of rotation (see operating instructions of control unit)
4. Fill the tank up to the switch on position of the integrated level control until the starting point is reached.
5. The pump starts working and drains the tank. Check the pump process through the inspection hole. Close the inspection hole afterwards. Do not forget the seal. Check the tightness of the whole installation by several test runs.

Checking the alarm system

1. Lift the float of the level control through the open cleansing hole slowly by hand beyond the starting point, until the alarm system switches on. (alarm delay time appr. 12 sec.)
2. If the trial run and the alarm check was satisfactory let the float go and close the inspection hole. Do not forget the seal.

Operation

The sewage disposal unit operates automatically, depending on the water level in the tank. A test run can be started by actuating the test run push button. The operation is signalled by a green LED.

Stopping operation

Pull the main plug, isolate the main supply or take out the main fuses. If the inflow cannot be stopped it is wise to consider an emergency generator for power failures. The tank can also be drained by an additional hand diaphragm pump in case of power failures or other malfunctions.

Inspection

A monthly test run and check of the unit ensures the reliable operation and also the tightness of the pressure pipes, valves and connections.

Operating Instructions

Maintenance



Take out the main fuses to isolate the mains supply of both, control unit and pump, before any works and make sure it cannot be energized again. Check the cable on mechanical or chemical damages.



In accordance to the DIN EN 12056-4 servicing should be carried out in intervals of 6 months by competent personnel. Jung Pumpen disclaims all responsibility for work done by untrained, unauthorized personnel.



At using a chain to lift the pump, please pay attention to the rules for prevention of accidents. Chains have to be inspected regularly by qualified personal.



The motor of the UFK series has the protection type: flameproof enclosure. Only authorised workshops or the manufacturer are permitted to carry out repairs effecting the flameproofness. In case of repairs the gap peripheries have to be inspected for damages, defective parts must be replaced by genuine spare parts.

General safety

- clean the pump thoroughly
- beware of the risk of infection
- follow local safety regulations

The pump is designed for use in liquids which can be dangerous to health. When working on the pump, prevent injuries to the eyes and skin, by:

- wearing goggles and rubber gloves
- cleaning the pump before any works
- cleaning the parts after dismantling
- hold a cloth over the drain plug to prevent splatter when opening the oil chamber

In case of contact with dangerous liquids:

- eye contact: rinse your eyes immediately in running water for 15 min. Hold your eyelids apart with your fingers. Contact an eye specialist
- skin contact: remove contaminated clothes, wash your skin with soap and water, seek medical attention, if necessary

To keep the reliability of operation the first oil change of the seal chamber should be made after 300 working hours, after that the oil should be changed every 1000 working hours, not later than once a year.

If the pump delivers water with abressive additions servicing should be carried out at adequate shorter intervals. At decreasing flow rates or ascending noises the impeller has to be checked on wear, and if necessary, it has to be changed.

The servicing should contain:

1. Checking the tightness of the whole installation including flexible connections, valves
2. Checking of valves including adjusting and greasing if necessary.
3. Opening and cleaning of the reflux valve, checking of valve face and ball or flap.
4. Cleaning of the pump and the pressure outlet, checking of impeller and bearing clearance.
5. Checking the oil chamber and oil-level (if oil chamber exists)
6. Cleaning of the tank, if necessary in accordance to special requirements.
7. Checking of the electrical system, voltage, sense of rotation (3-phase units only), current consumption of each motor, motor protection and adjusting value, test button, level control and indicators.
8. Checking of tank condition.
9. Rinsing the hole installation thoroughly at least every second year.
10. Re-initiation of the unit with test run.
11. Providing a test-report with declaration of all works that have been carried out and all measured values.

Operating Instructions

Malfunctions

Pump does not run

- cause: missing mains supply
remedy: check supply voltage
- cause: faulty fuse (maybe too low)
remedy: check fuse and change if necessary
- cause: damaged supply cable
remedy: changing of the cable gland only by qualified personnel

Pump does not run, no power failure, no alarm

- cause: jammed float
remedy: close inlet sluice valve, switch off the mains supply, open the cleansing hole and move the float up and down until it moves freely

Pump does not run, no power failure, alarm is signalled and float works properly

- cause: released winding thermostat because of electrical or mechanical overload of the pump. (tightened or blocked impeller, electrical motor fault)
- remedy: close inlet sluice valve, switch off mains supply, empty the tank, unscrew the 6 hexagon head screw M 10 x 30 (part-No. 19685) on the pump base, take off the pump, check the impeller and the cutting system and remove blocking parts if necessary. If there is no mechanical problem the electrical fault finding should only be done by qualified electricians.

Pump runs but without / low capacity and alarm is signalled

- cause: wrong phase sequence of the mains supply or one phase is missing
(result: lower or missing pump flow rate)
- remedy: change two of the three leads with the phase inverter (see operating instructions ADZ ...)
- cause: closed sluice valve in the discharge pipe
remedy: check sluice valve and open it
- cause: clogged reflux valve
remedy: switch off mains supply, close sluice valve, open the reflux valve, check and clean it
- cause: clogged pressure pipe
remedy: rinse the pressure pipe thoroughly
- cause: trapped air in the spiral housing
remedy: take off the deaeration hose (part-No. 01588) and clean it
clean the deaeration hole in the pump and in the fitting of the tank

Unit operates too noisy at the end of operation

- cause: follow up time is too long
remedy: adjust follow up time
(see operating instructions ADZ ...)

CE

Jung Pumpen GmbH & Co
Industriestraße 4-6 - 33803 Steinhagen

XX¹

EN 12050-1

Fäkalienhebeanlage DN 80/100
Hebewirkung – siehe technische Daten
Geräuschemissionswert < 70dB (A)
Korrosionsschutz – Kunstharzlack

¹ Die beiden ersten Ziffern der Pumpen-Nr. bezeichnen das Produktionsjahr.

Operating Instructions

Picture 4: compli 1000

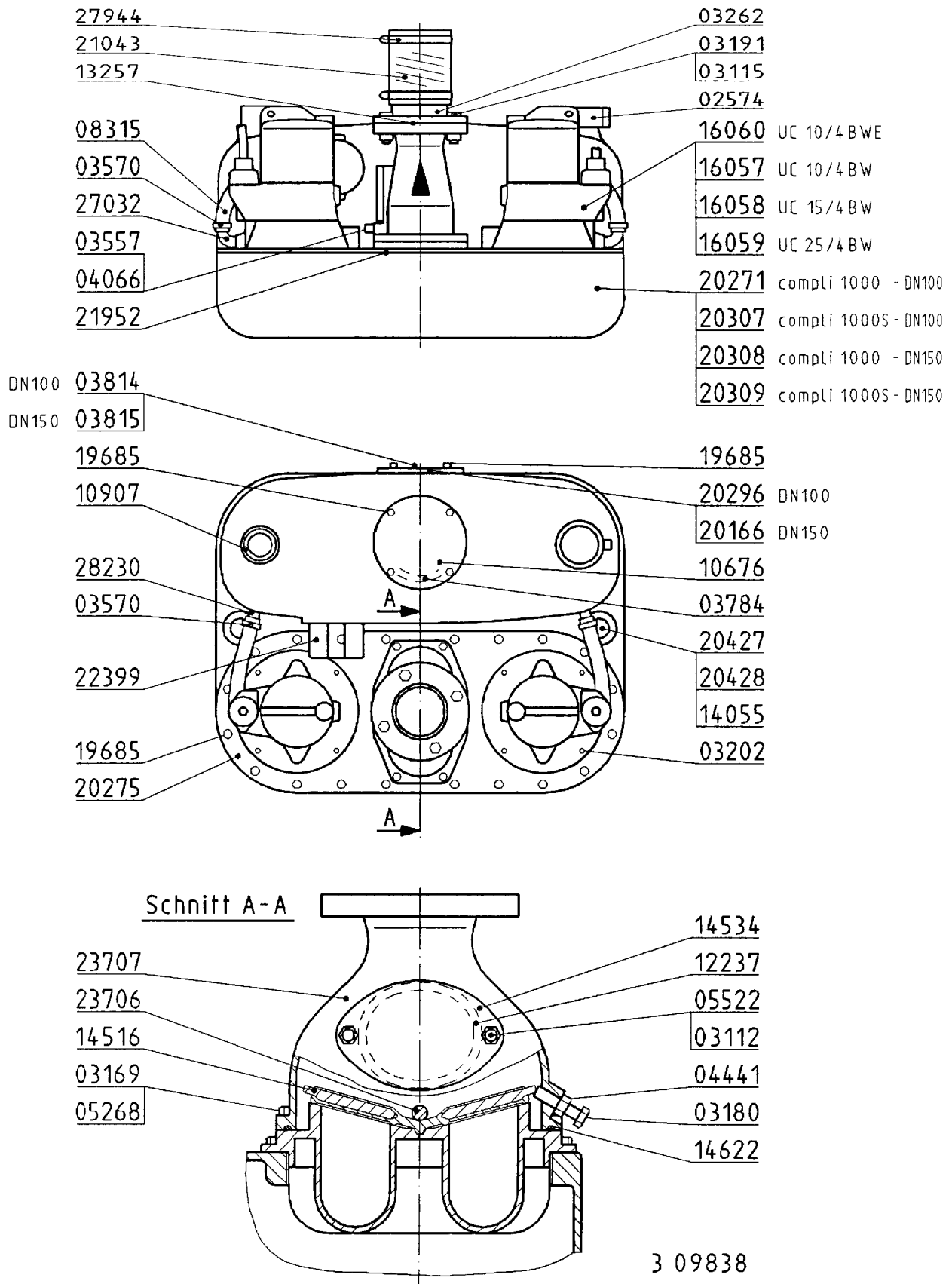

Operating Instructions

No.	Code-No.	Description	Qty. compli			
			1010/4 BW E	1010/4 BW	1015/4 BW	1025/4 BW
1	02574	elastic connector with clamps	1	1	1	1
2	03112	hexagon nut M 12	2	2	2	2
3	03115	hexagon nut M 16	4	4	4	4
4	03169	hexagon head screw M 10 x 30	4	4	4	4
5	03180	hexagon head screw M 12 x 50	1	1	1	1
6	03202	hexagon socket screw M 6 x 16	8	8	8	8
7	03262	spigot flange DN 100	1	1	1	1
8	03557	plug ½"	1	1	1	1
9	03570	hose clamp Ø 20 – 32	4	4	4	4
10	03784	O-ring 142 x 6	1	1	1	1
11	03814	O-ring 105 x 15 (DN 100)	1	1	1	1
12	03815	O-ring 155 x 15 (DN 150)	1	1	1	1
13	4066	washer 8,4	1	1	1	1
14	04441	hexagon flanged nut M 12	1	1	1	1
15	05268	washer A 10,5	4	4	4	4
16	05522	stud M 12 x 25	2	2	2	2
17	08315	hose Ø 20 x 290 mm	2	2	2	2
18	10676	blind flange	1	1	1	1
19	10907	plug in seal d 50 x D 59	1	1	1	1
20	12237	O-ring 100 x 7	1	1	1	1
21	13257	gasket DN 80, PN 10	1	1	1	1
22	14055	plug S 14	2	2	2	2
23	14416	valve flap compli 1000	1	1	1	1
24	14533	service cover	1	1	1	1
25	14622	O-ring 212 x 7	1	1	1	1
26	19685	hexagon head screw 10 x 30 „Amtec“	28	28	28	28
27	20166	clamping flange DN 150	1	1	1	1
28	20271	tank compli 1000, inlet DN 100	1	1	1	1
29	20275	pump base compli 1000	1	1	1	1
30	20296	clamping flange DN 100	1	1	1	1
31	20307	tank compli 1000 S, inlet DN 100	1	1	1	1
32	20308	tank compli 1000, inlet DN 150	1	1	1	1
33	20309	tank compli 1000 S, inlet DN 150	1	1	1	1
34	20427	hexagon head wood screw 12 x 250	2	2	2	2
35	20428	washer 65 x 14 x 3	2	2	2	2
36	21043	elastic connection 4" x 200 mm	1	1	1	1
37	21952	sealing compound Ø 12 x 1850 mm	1	1	1	1
38	23706	arbor for duplex swing type check valve	1	1	1	1
39	23707	hosuing of duplex swing type check valve	1	1	1	1
40	27032	elbow 21 x ½"	1	1	1	1
41	27944	fastening clamp W1, 4"	2	2	2	2
42	28230	taper nipple ½" x 30 mm	2	2	2	2

Replacement kits

25298	control unit BD 00 EC	16060	sewage disposal pump UC 10/4 BWE
302	control unit BD 25	16057	sewage disposal pump UC 10/4 BW
14358	control unit BD 46	16058	sewage disposal pump UC 15/4 BW
25298	control unit BD 610	16059	sewage disposal pump UC 25/4 BW
20848	rotary level control	26219	sewage disposal pump UC 25/2 BW / 1
16603	cable with CEE plug	26220	sewage disposal pump UC 35/2 BW / 1
22399	operating instructions for rotary level control unit		

By ordering spare parts indicate type of the pump and the part number

Operating Instructions

JUNG PUMPEN GmbH & Co KG
Industriestr. 4-6
33803 Steinhagen, Germany

Tel. 05204 17 - 0
Fax 05204 80368
e-Mail info@jung-pumpen.de



EG - Konformitätserklärung Declaration of EC - Conformity Attestation de Conformité CE

**Hiermit erklären wir, daß alle Exemplare unserer Geräte
Herewith we declare that all our devices
Nous attestons par la présente, que tous nos produits**

Fäkalienhebeanlagen – Typ:
compli 500, 600, 1000, 1200, 1500, 2500

**den wesentlichen Schutzanforderungen folgender EG – Richtlinien entsprechen :
comply with the following provisions applying to :
correspondent aux principales directives CE suivantes :**

EG-Niederspannungsrichtlinie 73/23/EWG i.d.F. 93/68/EWG
EG-EMV Richtlinie i.d.F. 89/336/EWG
EG-Bauproduktenrichtlinie 89/106/EWG

**Angewendete harmonisierte Normen, insbesondere :
Applied harmonized standards in particular :
Principales normes harmonisées :**

73/23/EWG	89/336/EWG	89/106/EWG
EN 60 730 -1 (bis 3,2kW)	EN 55 014 -1	EN 12050-1
EN 60 204 -1 (über 3,2kW)	EN 55 014 -2	
EN 60 034 -5	EN 61000 -3 -2/3	

**Angewendete, nicht unter obige EG Richtlinien fallende technische Normen und Spezifikationen :
Applied national technical standards and specifications in particular :
Normes et spécifications n'entrant pas dans les directives ci-dessus :**

EN 292 Teil 1 + 2
EN 809

Bei einer nicht mit uns abgestimmten Änderung des Gerätes verliert diese Erklärung ihre Gültigkeit.
By altering the device without approval the declaration would invalidate.
Toute modification de la machine, effectuée sans notre accord, annule la validité de la présente déclaration.

Steinhagen, den 23.06.2003

(Schweitzer)
Geschäftsführer

(Abel)
Techn.Geschäftsleitung

40104090.doc / TB – Sn
Ersetzt dito. vom 14.01.03