

Application

These robust submersible drainage pumps US 73 Ex and US 103 Ex can be used for the handling of contaminated water containing fibres and particles up to 30 mm size (no stones). The pumps are suitable for mounting in collection chambers and pits located in hazardous areas. Hazardous areas are usually designated where the drainage system is fed from areas with vehicles, car parks, garages, tank farms or laboratories, etc.
 Type of protection Ex II 2 G EEx d IIB T4
 The light weight of the pumps and low power consumption make the unit ideal for dealing with contaminated liquids in an economic manner.

This range of pumps is suitable for stationary and portable use. For easy removal of the pumps from deep sumps we recommend the use of our guide rail systems GR 40 which provide ease of maintenance and inspection. A controllable oil chamber and wear-resistant special mechanical seal ensure a long service life. For automatic monitoring of the oil chamber a seal leak control can be connected.

According to Ex-proof testing regulations, these pumps are provided with winding thermostats and can only be used with the equivalent control unit (see accessories). The pumps must not be used for raising sewage from lavatories and urinals.



US 103 Ex

Performance

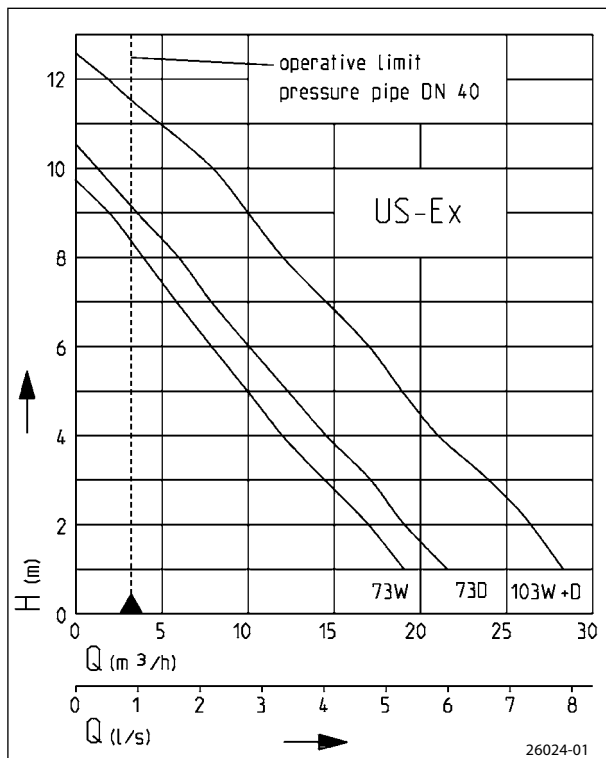

We reserve the right to change specifications without notice
 Pump performance is subject to ISO 9906 tolerances
 The minimum flow velocity in the pressure piping must be 0.7 m/s according to EN 12056.
 This data is represented in the performance curve as a limit of application.

- Stationary use
- 30 mm free passage
- Controllable oil chamber
- SiC mechanical seal independent of rotation direction
- Moisture sealed cable inlet



Heavy duty submersible drainage pumps US 73 Ex and US 103 Ex

Submersible sump pumps

Type	Maximum Height x Width	Discharge branch	Free passage	Cable quality H07RN-F-	Cable length	Weight approx.	Code No.
US 73 Ex W	330 x 215 mm	1½"	30 mm	6G1.5	10 m	19.0 kg	09292
US 73 Ex D	330 x 215 mm	1½"	30 mm	6G1.5	10 m	19.0 kg	00595
US 103 Ex W	360 x 215 mm	1½"	30 mm	6G1.5	10 m	21.5 kg	09294
US 103 Ex D	360 x 215 mm	1½"	30 mm	6G1.5	10 m	21.5 kg	09293

Performance

Type	Delivery head H [m]	1	2	3	4	5	6	7	8	9	10	12
US 73 Ex W	Flow rate Q [m³/h]	19	17	15	12	10	8	6	4	2		
US 73 Ex D		22	20	17	15	12	10	8	6	4		
US 103 Ex W/D		28	26	23	21	19	17	15	12	10	8	2

Electrical Data

Type	Type of current	Voltage Volt	Motor rating kW		RPM min. ⁻¹	Current Amperes	Motor protection	Plug
			P ₁	P ₂				
US 73 Ex W	Single-phase	1/N/PE~230	0.83	0.50	2510	3.9		without
US 73 Ex D	3-phase	3/PE~400	0.85	0.60	2800	1.4	in control unit + winding thermostats	without
US 103 Ex W	Single-phase	1/N/PE~230	1.37	0.98	2700	6.0		without
US 103 Ex D	3-phase	3/PE~400	1.36	1.06	2740	2.4		without

Example of single pump installation with GR

US 73 + 103 sump area with GR 40 min. 40 x 60 cm
 US 73 + 103 sump area without GR min. 40 x 40 cm
 (without illustration)

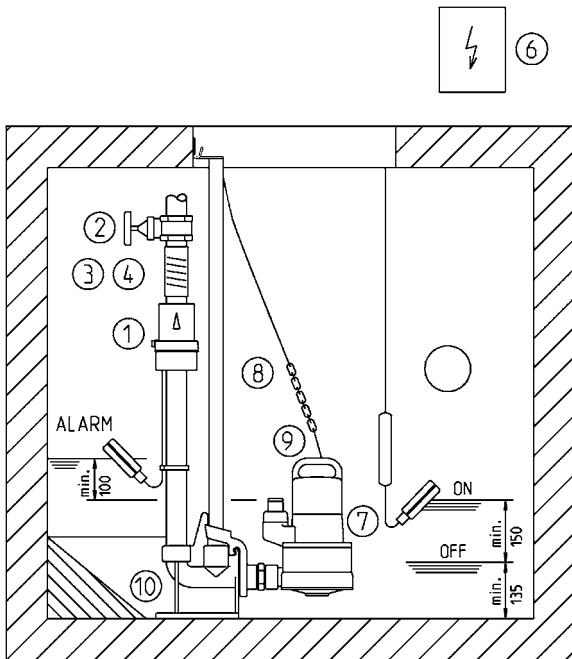

25899-05

In case of installation beneath the backpressure level the pressure tube must be taken in a loop over the local backup level acc. to EN 12056. Besides, it must be secured with an EN 12050-4-proofed swing-type check valve. Additionally we recommend an alarm system.

Example of duplex pump installation

US 73 + 103 sump area without GR min. 40 x 60 cm
 US 73 + 103 sump area with GR 40 min. 60 x 60 cm
 (without illustration)
 Suspend control unit in a dry room.

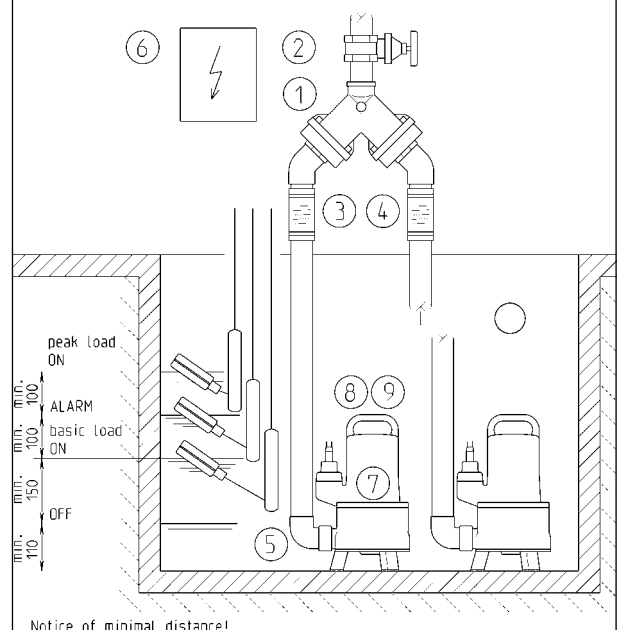



Notice of minimal distance!

25898-03

In accordance with DIN EN 12056-4 section 5.1, it has a built-in automatic spare pump or a double attachment included, which ensures that sewage drainage is not interrupted.

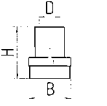
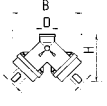
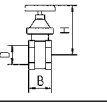
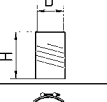
Accessories

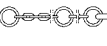
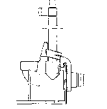
			Code No.	US 73 Ex W	US 73 Ex D	US 103 Ex W	US 103 Ex D
	① Swing-type check valve 1½" (DN 40), PN 4 DIN EN 12050-4	H W D 150 120 1½"	00317	•	•	•	•
	Duplex swing-type check valve 1½" (DN 40), PN 4 for duplex pump station, DIN EN 12050-4	H B D 200 280 1½"	09155	•	•	•	•
	② Stop valve 1½" (DN 40), PN 16	H B D 125 max. 60 1½"	11837	•	•	•	•
	③ Elastic connection 1½" (DN 40), PN 4	H Dia. inside 120 50	20368	•	•	•	•
	④ Hose band clamp 1½"		03571	•	•	•	•
	⑤ Elbow 1½"		17894	•	•	•	•
	⑥ Separate level controls for single units						
	First option	AD 4 Ex W	25901	•			
		AD 8 Ex W	25902			•	
		AD 23 Ex	09754		•		
		AD 25 Ex	09683				•
		Auxiliary switch module Ex II	14427	•		•	
		Auxiliary switch unit ExH-A	16720	•	•	•	•
		Level control package AmG	16719	•	•	•	•
	Second option	AD 4 Ex W	25901	•			
		AD 8 Ex W	25902			•	
		AD 23 Ex	09754		•		
		AD 25 Ex	09683				•
		Air diaphragm control unit	01080	•	•	•	•
	Control units for duplex unit						
	First option	BD 23 Ex	09755		•		
		BD 25 Ex	09681				•
		Auxiliary switch unit ExH-B	00295		•		•
		Level control package BmG	16726		•		•
	Second option	BD 23 Ex	09755		•		
		BD 25 Ex	09681				•
		Air diaphragm control unit	01080		•		•
	Control units for duplex unit with the pumps US 73 Ex W and US 103 Ex W as requested						
	⑦ Seal leak control DKG Ex		00249	•	•	•	•
	Chain with 2 rings DIN 766, 2.5 m, 320 kg		19189	•	•	•	•
	⑧ Chain stainless steel with 5 rings, 1 shackle NG 10, DIN 766, 2.5 m, 200 kg		23986	•	•	•	•
	⑨ Shackle A 0.6		13402	•	•	•	•
	⑩ Guide rail system GR 40		25592	•	•	•	•

* not for duplex units and GR 40

Heavy duty submersible drainage pumps US 73 Ex and US 103 Ex

Technical data

Pump

Vertical, single-stage, submersible, with free inlet, volute casing with 1 1/2" (female) discharge branch, open centrifugal impeller, passage 30 mm.

Bearings

Common shaft for pump and motor, arranged in ball bearings, lubricated by permanent grease filling.

Seal

Silicon carbide mechanical seal, oil chamber and duplex rotary seal towards the motor section, safe to run dry, a seal leak control can be connected.

Motor

Special submersible motor, type of enclosure IP 68, insulation class F, winding thermostat protects the motor from overload, tested by PTB for type of protection Ex (Ex) II 2 G EEx d II B T4 automatic activation through control unit only

Materials

Volute and motor casing in GG grey cast iron, vortex impeller, wear plate and pump base in synthetic material (GFK), shaft in stainless steel, power supply through rubber insulated flexible-cable.

Installation

Pump can be installed free standing or together with guide rail system type GR 40, which provides a detachable connection with swing-type check valve mounted in permanent position in discharge pipework.

Scope of supply

Pump according to DIN EN 12050 ready for connection with 10 m cable.

Dimensions US 73 Ex and US 103 Ex (mm)

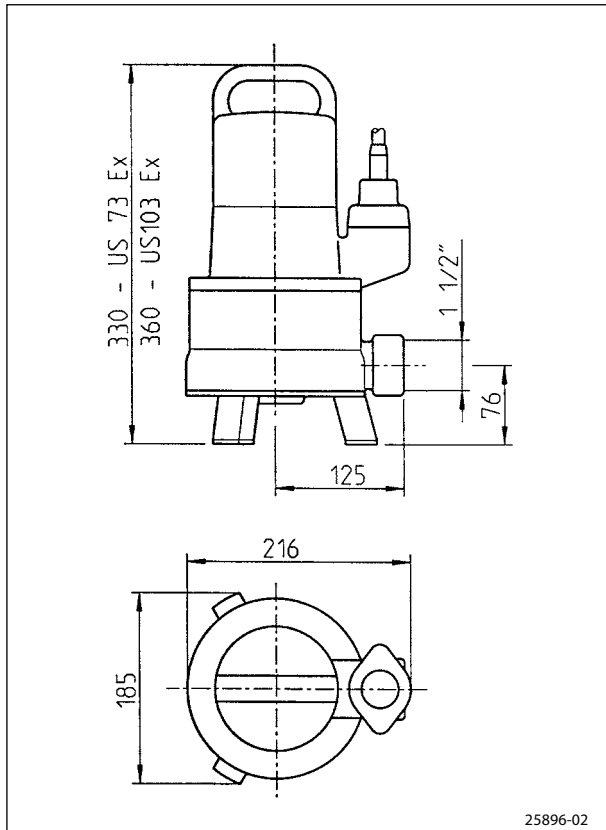

Dimensions with GR 40 (mm)

