

Above floor sump Hebefix

Application

The above floor sump Hebefix is a drainage pump station in mini size. It consists of a mountable or suspendable plastic tank (approx. 25 l) with an additional sleeve for 40 mm PVC/HT pipes at the top and three additional inlet on the sides. The lateral lower inlet sleeves have been designed for 50 mm PVC/HT pipes. The cellar drainage pump U 3 KS intended for the Hebefix tank is connected at the prepared pipe connection and pumps the grey water running in automatically to the next sewage pipe. Thus, a drain for a washbasin can be installed at any requested site - also below the backpressure level - without a lot of cumbersome masonry work and without excavating a pit. A washing machine, a dish washer, a bathtub and a shower tray can be connected as well.

The connection of a ventilation pipe passed to the roof prevents odours. If no ventilation pipe is connected, the activated carbon filter prevents annoyance caused by offensive odour. The installation of an alarm system (AWR 3) is recommended. It warns against impermissibly high water levels and switches the washing machine off, if and when required.

The scope of delivery includes the plastic tank with integrated connection hose, clamps, swing-type check valve as supplementation kit for U3 KS, activated carbon filter, hose connection for the washing machine (top, lateral connections), rubber feet and wall attachment parts **(without pump)**.

The unit is in conformity with the specification of German / European standard 12050.



Performance

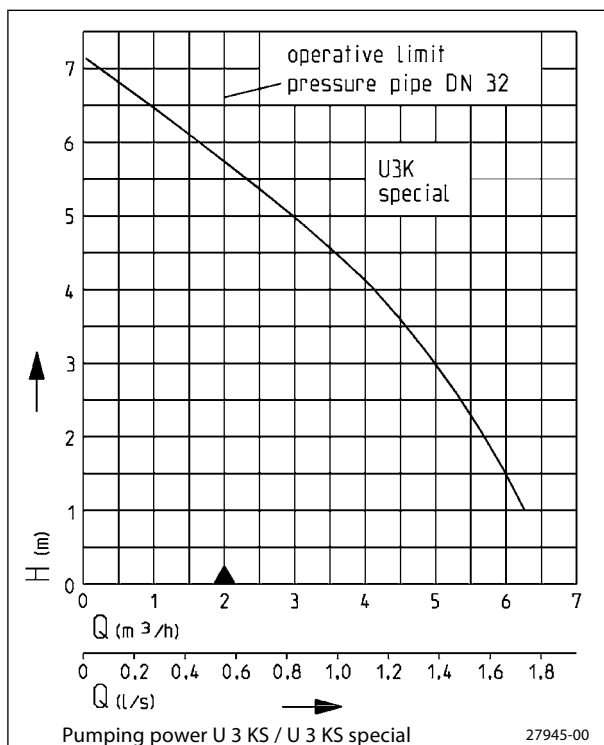

We reserve the right to change specifications without notice
Pump performance is subject to ISO 9906 tolerances
The minimum flow velocity in the pressure piping must be 0.7 m/s according to EN 12056.
This data is represented in the performance curve as a limit of application.

- Overflow protection
- Wall-hung installation
- Alarm system possible
- Disposal of condensate from condensation boilers (only with U 3 KS special)
- Lid with snap-on cap
- Direction of pressure drain variable
- Swing-type check valve
- Activated carbon filter



Mounting arrangement - Hebefix (ground erection)

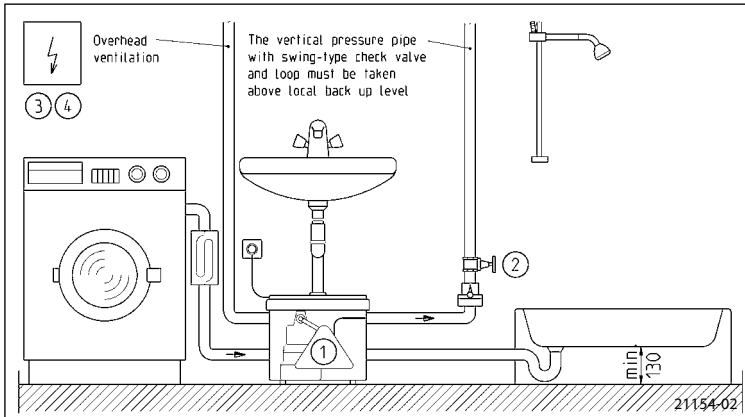

Hebefix (wall-mounted)

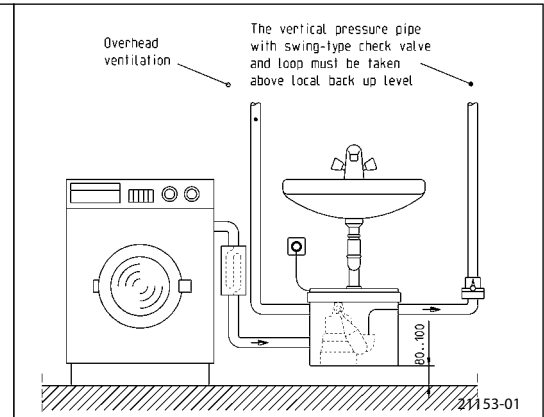

Dimensions (mm)

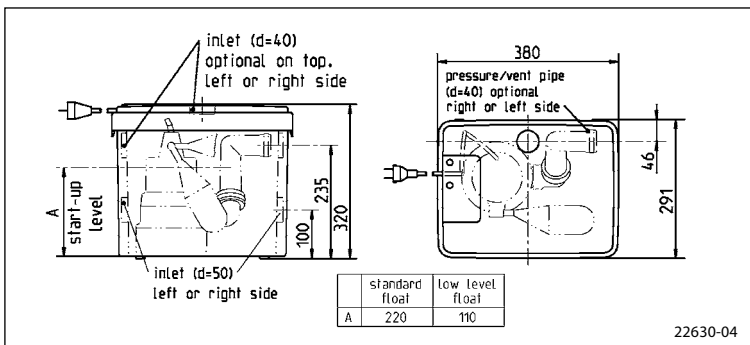

The additional lower inlet on both sides (H 100 mm) can be used to install Hebefix 100 in a level shower tray backpressure safe. The series float switch of U 3 KS then has to be replaced by the special float switch. If the installation of an alarm circuit is planned, the corresponding attachment of the alarm switch has to be provided. (Please observe when ordering!) Hebefix can be erected on the floor. A wall suspension is possible as well in order to achieve more ground clearance to permit easy and fast cleaning.

Above floor sump

Type	Largest height x width x depth	Connections	Weight approx.	Code No.
Hebefix tank, white without pump	320 x 380 x 291 mm	3 x 40 mm 2 x 50 mm	3 kg	01063
placeable pump U 3 KS (cable length 3 m)				00206
or U 3 KS (cable length 10 m)				09808
or U 3 KS special for condensate from condensation boilers				09563

Accessories

			Code No.
	① Special float switch for low switching heights (switching height ON approx. 110 mm, OFF approx. 50 mm)		17424
	② Stop valve	1 1/4" (DN 32), PN 16	H B D 110 max. 60 1 1/4"
	③ Alarm system mains-dependent, with potential-free make contact		20198
	Alarm system AWR 3 with washing machine cut off		25092
	with reed switch, separate, mains-dependent and 3 m cable		
	Fastener for alarm switch (only U3KS with special float switch)		28191
	④ Rechargeable battery for mains-independent alarm		07562

Performance

Type	Delivery head H [m]	1	2	3	4	5	6
U 3 KS	Flow rate Q [m³/h]	6.5	5.5	5.0	4.0	3.0	1.5
U 3 KS special		6.5	5.5	5.0	4.0	3.0	1.5