

Spare parts

Pos.	Code-No.	Description	Qty
1	22583	duckfoot bend	1
2	28027	guide rail claw incl. No. 3 + 4	1
3	27956	profiled seal DN 65	1
4	22551	hexagon head screw M 12 x 45, A2	4
5	17766	hexagon nut M16	4
6	28523	plug M16	4
7	14055	plug S14	1
8	17921	wood screw 12 x 60	2
9	40104	bracket 1"	1
10	40124	hex. head screw M6 x 35	2
11	40106	rubber clamping sleeve 1"	2

Replacement kits

28514 guide rail claw complete, consisting of Pos. 2, 3, 4

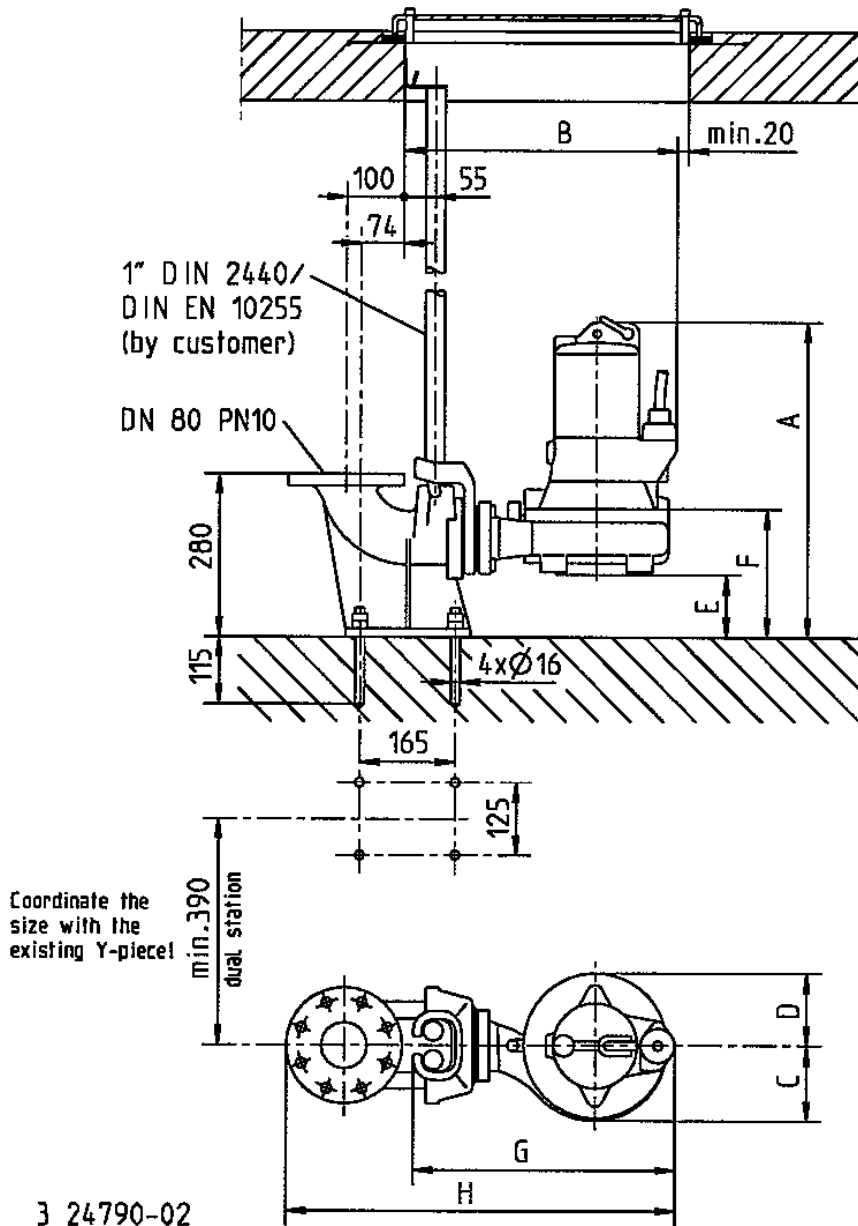

pumpe type	A	B	C	D	E	F	G	H
10/2 A1	510	455	110	105	108	213	435	660
15/2 A1	510	455	110	105	108	213	435	660
25/2 A2	510	475	130	125	108	220	455	680
35/2 A2	545	475	130	125	108	220	455	680
25/2 AW	500	490	130	130	115	220	470	690
35/2 AW	535	490	130	130	115	220	470	690
15/26A1	510	455	110	105	108	213	435	660
25/26A2	545	475	130	125	108	220	455	680