

## General Safety Instructions

### Application

### Electrical Connection

### Installation

### Maintenance



## Submersible sewage pumps

UFK types with explosion protection

 II 2 G EEx d IIB T4

PTB 02 ATEX 1042

You have bought a Jung Pumpen product and therefore purchased quality and performance. Guarantee this achievement by an installation according to the operating instructions so that our product can meet your demands to your full satisfaction. Please note that damages as a result of poor installation will affect the guarantee.

For this reason please follow the advice of the operating instructions.

Like any other electrical appliance the operation of this product can fail by electrical failure or technical faults. It is wise to always consider standby pumps, emergency generator and a control unit fitted with mains independent alarm.

UAK 25/2 A2	ID-No. 09617 / 04
UFK 25/2 A2	ID-No. 09630 / 04
UAK 35/2 A2	ID-No. 09651 / 04
UFK 35/2 A2	ID-No. 09653 / 04
UAK 15/4 B3	ID-No. 09622 / 04
UFK 15/4 B3	ID-No. 09635 / 04

# Operating Instructions

---

## General Safety Instruction

This operation manual gives basic instructions that should be followed carefully during installation, operation and maintenance. It is essential that this manual is carefully read by the responsible personnel/operator before assembly and commissioning. It is always to be kept available at the installation site.

## Identification of safety instructions in the operating manual

Safety instructions given in this manual non-available with which would affect safety are identified by the following symbol:



General danger for personnel



Dangerous voltage



Danger for machine and function

It is imperative that signs affixed to the machine, e.g.

- rotation arrow
- fluid connection symbols
- data / approval plate

be observed and kept legible.

## Qualification of personnel

An authorized (certified) electrician and mechanic shall carry out all work. Scope of responsibility and supervision of the personnel must be exactly defined by the plant operator. If the staff does not have the necessary knowledge, they must be trained and instructed, which may be performed by the machine manufacturer or supplier on behalf of the plant operator, moreover, the plant operator is to make sure that the contents of the operating manual are fully understood by the personnel.

## Hazards in the event of non-compliance with the safety instructions

Non-compliance with the safety instructions may produce a risk to the personnel as well as to the environment and the machine and results in a loss of any right to claim damages or compensation. For example, non-compliance may involve the following hazards:

- Failure of important functions of the machine/plant
- Failure of specified procedures of maintenance and repair
- Exposure of people to electrical, mechanical and chemical hazards
- Endangering the environment owing to hazardous substances being released.

## Safety regulations for owner / operator

All safety instructions contained in this manual, all relevant national and local health and safety codes and any other service and safety instructions issued by the plant operator shall be complied with.

## Safety instructions relevant for operation

If hot or cold machine components involve hazards, they must be guarded against accidental contact.

Guards for moving parts (e.g. coupling) must not be removed from the machine while in operation.

Any leakage of hazardous (e.g. explosive, toxic, hot) fluids (e.g. from the shaft seal) must be drained away so as to prevent any risk to persons or the environment. Statutory regulations are to be complied with. The pumping station must be kept tidy and in good condition.

Hazards resulting from electricity are to be prevented (see for example, the national-specifications or the regulations of your local electricity supply company.)

## Safety instructions relevant for maintenance, inspections and assembly work

It shall be the plant operator's responsibility to ensure that all maintenance, inspection and assembly work is performed by authorized and qualified personnel who have adequately familiarized themselves with the subject matter by studying this manual in detail.

Any work on the machine shall only be performed when it is at a standstill, it being imperative that the procedure for shutting down the machine described in this manual be followed.

Pumps and pump units which convey hazardous media, must be decontaminated. All waste emissions such as used oil must be appropriately disposed of, oil spills must be cleaned up and emissions to the environment must be reported. On completion of work all safety and protective facilities must be reinstalled and made operative again.

Prior to restarting the machine, the instructions listed under "Electrical Connection" and "Installation" are to be observed.

## Unauthorized alterations and production of spare parts

Any modification may be made to the machine only after consultation with the manufacturer. Using spare parts and accessories authorized by the manufacturer is in the interest of safety. Use of other parts may exempt the manufacturer from any warranty or compensation claims.

## Unauthorized modes of operation

The reliability of the machine delivered will be only guaranteed if it is used in the manner intended, in accordance with clause 1; of this manual: The limit values specified in the data sheet must under no circumstances be exceeded.

## Warranty claim

Jung Pumpen pumps are long living, high quality products with expected reliable operation. However, should the need arise for a warranty claim, please contact your Jung Pumpen distributor.

# Operating Instructions

---

## List of contents

- General safety instructions..... page 2
- List of contents..... page 3
- Technical data ..... page 4
  - Application
  - Transportation and storage
- Safety precautions ..... page 5
- Installation ..... page 6
  - Electrical connection
  - Sense of rotation
  - Winding thermostat
  - Wiring diagram
  - Operation through frequency converter
- Installation ..... page 7
  - Installation with guide rail system
  - Mobile operation
- Maintenance ..... page 8 - 10
  - Maintenance
  - Checking the seal chamber
  - Oil changing
  - Adjustment of impeller
  - Cleaning
  - Replacement of impeller
  - Malfunctions
- Sectional drawing ..... page 11
- Spare parts list ..... page 12

# Operating Instructions

## Technical Data

	UAK			UFK		
	25/2 A2	35/2 A2	15/4 B3	25/2 A2	35/2 A2	15/4 B3
Supply voltage [V]	3 x 230 / 400					
Power input P1 [kW]	2,60	3,70	1,80	2,60	3,70	1,80
Nominal current [A]	7,6 / 4,4	11,2 / 6,5	5,8 / 3,3	7,6 / 4,4	11,2 / 6,5	5,8 / 3,3
cos phi	0,86	0,83	0,78	0,86	0,83	0,78
r.p.m. [1/min]	2800	2890	1385	2800	2890	1385
weight [kg]	48	52	50	48	52	50
test certificate	02 ATEX 1042					
explosion proofness	Z-53.2-339					
explosion proofness	EEx d IIB T4					
Mode of operation: intermittent service S3	40 %					
max. switch. frequency	60 / h					
max. water temperature	1 - 40° C					
Protective system	IP 68					

## Description

This manual applies to a Jung Pumpen submersible sewage pump with single channel impeller. Observe the special handling instructions of the Ex-approved UFK type.

## Application

- The pumps of the UAK, UFK and the UC series are designed for sewage in the domestic, industrial and municipal sectors. The pumps are ideally suited to deliver sewage and wastewater with the usual admixtures (see DIN 1986, part 3) to the next gravity sewer in remote situations. In some countries sumps with a connection to the public sewer are an explosion hazardous location. For this application the explosion proof UFK type is necessary, for further information ask your distributor.
- At different operating conditions in explosion hazardous locations please ask the industrial and trade supervision, the building inspection or the employer's liability insurance association.
- Allowed temperature of pumped medium:  
Continuous operation : 40 °C (S1-operation)  
Intermittent operation :S3 operation, 15 %  
(1,5 min. operation, 8,5 min. stand by)
- If kept dry the pump can be stored down to a minimum temperature of -20°C. The flooded pump must not freeze.
- noise emission: >70 dB (A)

## Transportation and storage

The pump can be transported and stored in vertical or horizontal position.



Always use the shackle to carry the pump, never lift it at the cable. Make sure the pump cannot roll or fall over and injure people or damage property.

If kept dry the pump can be stored down to a minimum temperature of -20°C. The flooded pump must not freeze.

For longer periods of storage, the pump must be protected against moisture and heat. The impeller should be rotated occasionally to prevent the seals from sticking together.

After a long period of storage, the pump should be inspected before it is taken into operation. Pay special attention to the seals and the cable gland.

Follow the instructions of „Operation“.

# Operating Instructions



Please pay attention to the following regulations at installing the pump(s) or ask your qualified electrician / distributor.

- regulations for electrical installations (in Germany: VDE 0100, VDE 0165)
- regulations for prevention of accidents in sewage technical installations (in Germany: GUV 7.4, GUV 17.6)
- guidelines for explosion protection (in Germany: GUV 19.8)
- electrical installations in explosion hazardous areas (in Germany: Elex V)

## Safety precautions

In order to minimize the risk of accidents in connection with the service and installation work, the following rules should be followed:

- Never work alone. Use a lifting harness, safety line and a respirator as required. Do not ignore the risk of drowning.
- Make sure there are no poisonous gases within the work area.
- Check the explosion risk before welding or using electric hand tools.
- Do not ignore health hazards. Observe strict cleanliness.
- Bear in mind the risk of electrical accidents.
- Make sure that the lifting equipment is in good condition.
- Provide a suitable barrier around the work area, e.g. guard rail
- Make sure you have a clear path of retreat.
- Use safety helmet, safety goggles and protective shoes.
- All personnel who work with sewage systems must be vaccinated against diseases to which they may be exposed.
- A first-aid kit must be close at hand.
- Note that special rules apply to installation in explosive atmosphere.

Follow all other health and safety rules and local codes and ordinances

## Electrical connection



- Following works should only be done by qualified and authorized electricians.

- Jung Pumpen disclaims all responsibility for work done by untrained or/and unauthorized personnel.



- Heed operating voltage !  
(see name plate and additional labels)

- Take out the main fuses to isolate the mains supply from the control unit before repairs or any other works and make sure it cannot be energized again.
- If the pump is equipped with automatic level control, there is a risk of sudden restart.
- Before starting check the efficiency of the protective arrangements of the pump and the monitoring equipment. Failure to heed this warning may cause a lethal accident.
- Do not put the lead ends into water!  
Irruption of water may cause malfunctions.

- If persons are likely to come into physical contact with pump or pumped media, the earthed (grounded) socket must have an additional connection to an earth- (ground) fault protection device (GFI).
- When pumping near a lake, a jetty, a pond etc. a safety distance of at least 20 m between the person and the pump is applicable. Do not place the pump directly in a pool. Observe the special safety regulations if used in connection with swimming pools.
- Use the pump only in accordance to the data stated on the pump's plate resp. in the technical data on page 4.



**WARNING**

Special rules apply to installation in explosive atmosphere.

Intrinsically safe circuits (Exi) are normally required for the automatic level control system by level regulators.

- A Jung Pumpen control unit gives you the certainty of design under safety regulations and an acceptance of work without any problems.
- Level sensors must be used at low voltage. For further details please see data sheet / o.m. Local rules may specify otherwise.
- To prevent the pump from blocking after long rest periods an additional daily trial run unit can be installed.
- Connection only to a mains supply installed in accordance to the local regulations. For fusing use only 16 A slow fuses or automatic circuit-breaker with C or D characteristic. (former G and K)
- Because the motor's nominal voltage is measured at the terminal board of the pump, please consider the voltage drop of long supply cables.
- The motors of the three-phase a.c. pumps must be protected by a suitable overcurrent release. Adjustment as following:  
direct start: + 10% of the nominal current  
star-delta start: (nominal current x 0,58) + 10 %  
If the protective arrangement has triggered, eliminate the trouble
- Replace the cable if the cable jacket is damaged. Do not pinch the cable or pull it around sharp bends.
- Always install the control unit in a dry and well ventilated room above the backpressure level. Never install the control unit in the sump !

## Earthing

For safety reasons, the earth conductor should be appr. 50 mm (2 inch) longer than the phase conductors. If the motor cable is jerked loose by mistake, the earth conductor should be at last conductor to come loose from its terminal. This applies to both ends of cable. Ensure the correct earthing of the pump and the control unit.

# Operating Instructions

**Picture 1:** low voltage motor wiring

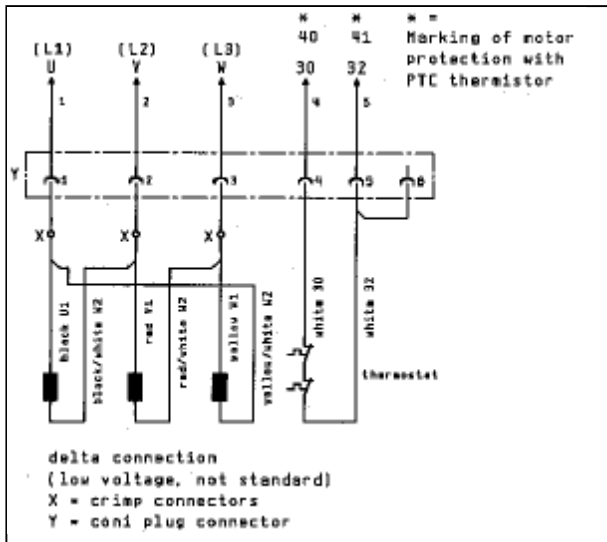

Wiring changes should only be made under use of conil plug or crimp connectors. The crimped connection must be made in a professional way under use of the correct tools, e.g. manufacturer: Grote & Hartmann, type: AZ 801 or AZ 901 according to the colours.

## Winding thermostat

Additionally to the overcurrent release and protective motor switches, the motor winding thermostats must be connected to the control device. They are suitable for 250 V and 1,2 A (cos. phi 0,6) and labeled 30 and 32. (see pict. 1)

## Winding thermostat connection UAK type

The protection of the motor winding has to be ensured by the control circuit, e.g. the secondary side of the motor contactor must be wired to the thermostats in such a way, that the pump motor will be switched off at the response temperature. After cooling down the pump will be restarted automatically.

## Winding thermostat connection UFK type

The protection of the motor winding has to be ensured by the control circuit, e.g. the secondary side of the motor contactor must be wired to the thermostats in such a way, that the pump motor will be switched off at the response temperature. After a thermal cutout eliminate the fault, before restarting the pump manually. The automatically restart of the motor after cooling down has to be prevented.



The reclosing lockout has to be non-resetting on voltage failure. ( even after a power failure the lock out still has be activated )

## Operation through frequency converter

**WARNING** If you want to operate pumps through a frequency converter please contact your distributor !

If the technical feasibility is already checked, the pumps have to be ordered as a special version !

They need a special PTC thermistor for motor protection and a tripping unit with a conformity certificate ! (e.g. PTB 3.53 – PTC/A)

Use frequency converters only for deceleration !

**Picture 2:** high voltage motor wiring

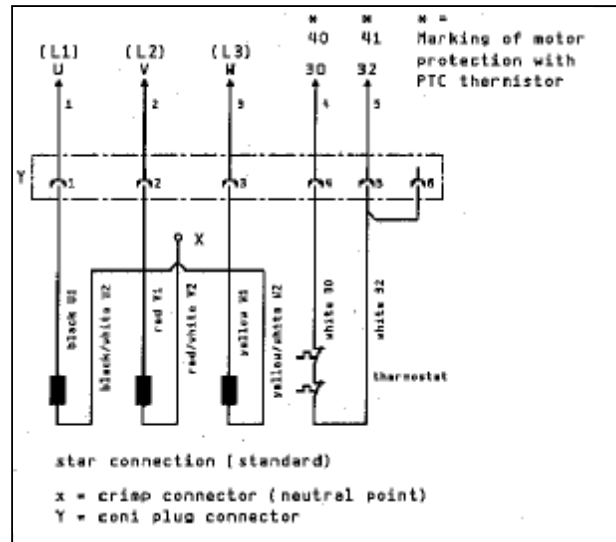

If three-phase current pumps are operated through a frequency converter, the r.p.m. change proportional to the input-frequency. Frequency converters have a setting range between nearly 0 Hz and more than 50 Hz. Because of physically reasons the pumps must not be operated with higher frequencies than indicated on the name plate. If the frequency rises beyond the rated value, the absorbed power escalates to the overload of the motor.

To recognize pumps with a PTC thermistor, please check the name plate. The last letter in the field of the motor type must be a K.

Example: motor type: D 160-4/200 K has a PTC thermistor and can be operated through a frequency converter. Pumps without this mark cannot be operated through a frequency converter.

Example: motor type: D 112-4/200

Additionally the pumps have a label at the lead end to point out the possible frequency converter operation.

Supply voltage of the PTC thermistor: max. 2,5 V !

## Sense of rotation

Before installation you have to check the sense of rotation. At correct rotating field the start bump of the pump is into the opposite direction to the arrow on the top of the pump. In case of wrong direction of rotation change two of the three phases of the mains supply.



Watch out for the start bump, which can be powerful

## Installation

To ensure the proper installation, consider the dimensions of the installation. The sump has to be cleaned from all sediments before any installation or repair works. The minimum height between the lifting hook and the floor shall be sufficient to lift the pump out of the sump. The lifting equipment shall be able to hoist the pump straight up and down in the sump, preferably without the need for resetting the lifting hook. Oversized lifting equipment could cause damages if the pump should stick when it is lifted.

The lifting equipment has to be securely anchored.

# Operating Instructions

**Picture 3:** installation example with guide rail system

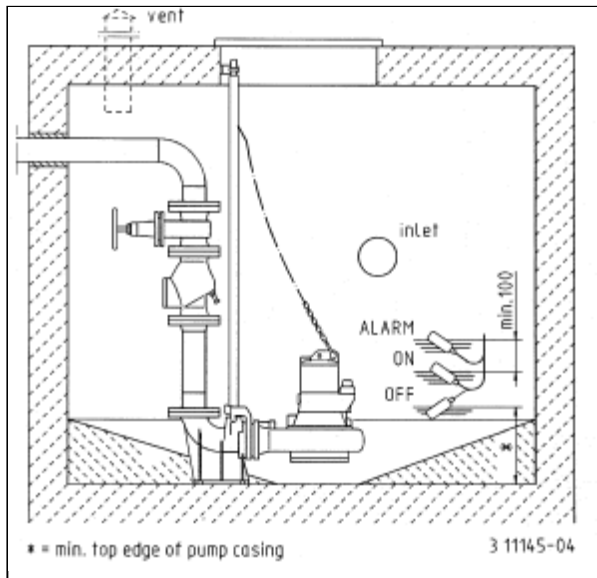

**Picture 4:** installation example of a mobile unit

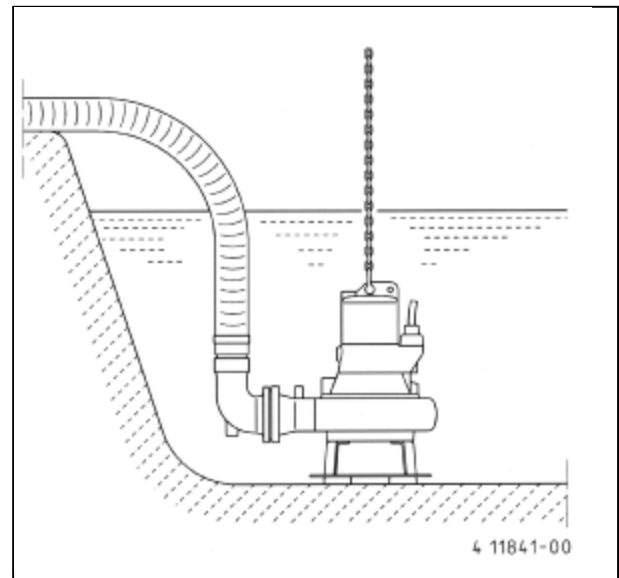

Always use the shackle to carry the pump, never lift it at the cable or the hose ! To lower the pump in a deep tank, use a rope or a chain.

**WARNING**

Before installation take off the 4 transport plastic pedestals from the pump bottom.

Stay clear of suspended loads.

Take out the main fuses to isolate the mains supply both control unit and pump before any works and make sure it cannot be energized again.

Make sure the pump cannot roll or fall over and injure people or damage property.

In some installations the water and the pump can be hot. Bear in mind the risk of burn injuries.

Before installation, please check:

- the visible parts of the pump and the installation
- sluice and reflux valves
- the oil level in the oil chamber
- if the impeller moves freely
- direction of rotation

The pump should be installed correspondingly to picture 3 and 4. Under DIN EN 12056-2 the pressure tube must be taken in a loop over the local back-up level and secured with a reflux valve. Observe the min. flow speed of 0,7 m/s in the pipe work.

## Stationary installation

To remove the pump easily we recommend our guide rail systems. Adjust the duck foot bend, drill the holes through the base of the duck foot bend and install the coupling unit, the guide tubes and the guide bracket with the enclosed screws and plugs. Install the pipe work including a ball reflux valve or a swing type check valve and a stop valve. Mount the guide rail claw on the pump, fasten the chain at the shackle and lower the pump via guide tube into the sump. A fastening device for a hoist simplifies the pump installation.

**WARNING**

Observe the measurements of the float switches as shown in picture 3.

The floats must not be installed below the inlet. The control unit must be installed in well ventilated room above the back pressure level.

## Mobile operation / deaeration

For mobile operation and retrofitting of existing sumps a pump base installation is uncomplicated and easy to maintain. Mount a 90° elbow to the discharge, install the pressure pipe, fasten the chain at the shackle and lower the pump into the sump. A fastening device for a hoist simplifies the pump installation.

**WARNING**

The float switches must not be installed below the inlet. The control unit must be installed in well ventilated room above the back pressure level. Climbing pressure pipe work has to be installed frost protected.

If a flexible hose is connected to the pump, no reflux valve must be installed and the hose must have a gradient to ensure a completely drained off hose when the pump stops working. When the pump is submerged again, water in the hose will prevent the deaeration of the spiral housing and therewith the correct operation of the pump. For the same reason the pump may not operate properly when it is submerged in switched on condition.

If this has happened take out the screw marked „Luft“ (width across 13 mm) and deaerate the spiral housing. If the pump is used in sumps that can dry out it is also possible to deaerate the spiral housing by drilling a Ø 8 mm hole in the pressure tube above the pressure outlet of the pump.

**WARNING**

In case of a damage at the pump a slight quantity of the oil chamber filling can leak into the pumping medium.

# Operating Instructions

## Maintenance



Take out the main fuses to isolate the mains supply of both, control unit and pump, before any works and make sure it cannot be energized again. Check the cable on mechanical or chemical damages.



At using a chain to lift the pump, please pay attention to the rules for prevention of accidents. Chains have to be inspected regularly by qualified personal.



The motor of the UFK series has the protection type: flameproof enclosure. Only authorized workshops or the manufacturer are permitted to carry out repairs effecting the flameproof ness. In case of repairs the gap peripheries have to be inspected for damages, defective parts must be replaced by genuine spare parts. Jung Pumpen disclaims all responsibility for work done by untrained, unauthorized personnel.

## General safety

- clean the pump thoroughly
- beware of the risk of infection
- follow local safety regulations

The pump is designed for use in liquids which can be dangerous to health. When working on the pump, prevent injuries to the eyes and skin, by:

- wearing goggles and rubber gloves
- cleaning the pump before any works
- cleaning the parts after dismantling
- hold a cloth over the drain plug to prevent splatter when opening the oil chamber

In case of contact with dangerous liquids:

- eye contact: rinse your eyes immediately in running water for 15 min. Hold your eyelids apart with your fingers. Contact an eye specialist
- skin contact: remove contaminated clothes, wash your skin with soap and water, seek medical attention, if necessary

To keep the reliability of operation the first oil change of the seal chamber should be made after 300 working hours, after that the oil should be changed every 1000 working hours, not later than once a year.

If the pump delivers water with abrasive additions servicing should be carried out at adequate shorter intervals. At decreasing flow rates or ascending noises the impeller has to be checked on wear, and if necessary, it has to be changed.

## Checking the seal chamber

The seal chamber has a filling- and drain plug with hexagon head (width across 13 mm). To check the mechanical seal put the pump into a horizontal position and drain the oil into a clean graduated measuring can. If the quantity of oil corresponds to the oil originally in place and is not discolored (milky) the primary mechanical seal is in good condition.

Milky or yellowish/grey oil indicates that water has leaked into the oil chamber. In this case the oil filling should be renewed and inspected again after a further 300 hours. If the oil is again found to be discolored or infiltrated by dirty particles the mechanical seal should be checked for wear and replaced if necessary.

For automatically monitoring of the seal chamber, the filling plug can be replaced by our seal leak detector DKG (Code-No. 00252) or DKG-Ex (Code-No. 00249).

## Oil changing

For the change of the oil, use spindle oil make: „ESSO“, type: Spinesso 22 or other mineral oils with a viscosity of 22 – 46, quantity: see spare parts list.

### WARNING

Do not overfill the seal chamber, otherwise the pump can seriously be damaged.

## Checking of pump unit

### WARNING

Worn out impellers can have sharp edges !

Inspect and adjust the impeller depending on the frequency of operation and the medium being pumped, but not later than half-yearly. At reduced pump performances or increased operational noises the impeller and the pump casing must be checked and replaced if necessary by qualified experts.

Picture 5: pump unit

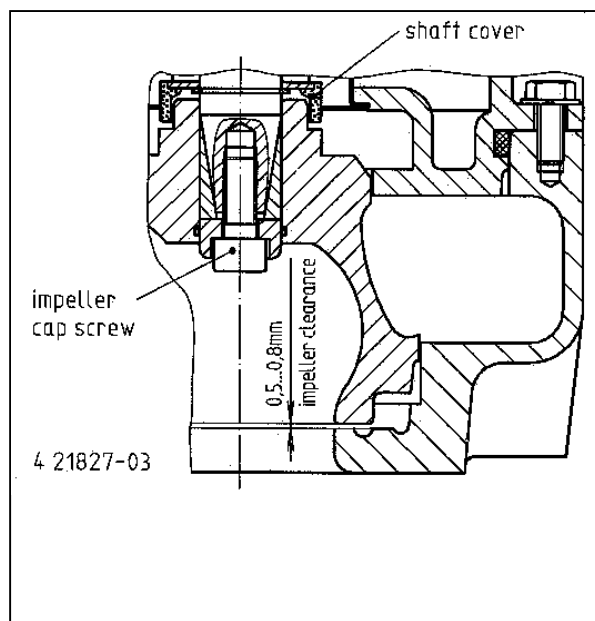

# Operating Instructions

---

## Checking of pump unit

Inspect and adjust the impeller depending on the frequency of operation and the medium being pumped, but not later than half-yearly. At reduced pump performances or increased operational noises the gap between the impeller and the wear plate must be checked with a thickness gauge. The correct impeller clearance is between 0,5 – 0,8 mm, larger clearances must be adjusted.

## Adjustment of impeller

1. Lock up the impeller with a piece of wood and unscrew the hex. socket screw M 10 x 25. (code-No. 21873).
2. Loosen the impeller with slightly hammer strokes.
3. Fasten the hex. socket screw M 10 x 25. (code-No. 21873) hand tight.
4. Adjust the gap to the nominal size by pulling down the impeller.
5. Lock up the impeller again and fasten the hex. socket screw M 10 x 25 (setting torque: 40 Nm (4,0 kpm))
6. Ensure the free turn of the impeller and check the impeller clearance again.
7. If the gap is still too large, repeat procedure 1 – 6. The max. setting range is 3,0 mm.

## Replacement of the impeller

If the pump performance cannot fully be reached the impeller and the spiral housing have to be checked on wear and must be changed by qualified experts if necessary.

1. Take the 4 hexagon head screws M 8 x 20 (code-No. 03155) out of the top of the spiral housing and lift off the motor unit.
2. Lock up the impeller with a piece of wood and unscrew the hex. socket screw M 10 x 25. (code-No. 21873).
3. Loosen the impeller with slightly hammer strokes and pull it off the shaft.
4. Clean the shaft connection properly.
5. Grease the shaft cover and impeller bushing.

**WARNING** Do not use grease containing graphite ! (e.g. „Molykote“)

6. Refit all parts of the shaft connection carefully and fasten the hex. socket screw M 10 x 25 hand tight.
7. Push the new impeller over the pre-assembled shaft connection onto the shaft.
8. Adjust the gap to the nominal size by pulling down the impeller.
9. Ensure the free turn of the impeller and check the impeller clearance again.
10. Mount the motor unit on the spiral housing, the cable gland has to be on the opposing side of the discharge branch.

## Cleaning

Regularly cleaning of the impeller and the level control sensors or float switches secures the maximum pumping capacity and operational reliability.

1. Take the 4 hexagon head screws M8 x 20 (code-No. 03155) out of the top of the spiral housing and lift off the motor unit.
2. Clean the impeller and the spiral housing.
3. Assemble the motor unit again carefully, check the impeller gap and adjust it if necessary.

**WARNING** If the wrong screws are untightend, oil will run out of the oil-chamber !

Torque ratio  $M_A$  for screw material:

for M 6, $M_A =$	8 Nm (0.8 kpm)
for M 8, $M_A =$	20 Nm (2.0 kpm)
for M 10, $M_A =$	40 Nm (4.0 kpm)
for M 12, $M_A =$	70 Nm (7.0 kpm)
for M 16, $M_A =$	160 Nm (16.0 kpm)
for M 24, $M_A =$	350 Nm (35.0 kpm)

# Operating Instructions

---

## Malfunctions

Pump does not run

- cause: missing mains supply
- remedy: check supply voltage
- cause: faulty fuse (maybe too low)
- remedy: check fuse and change if necessary
- cause: damaged supply cable
- remedy: changing of the cable gland only by qualified personnel

Pump runs, but doesn't deliver water

- cause: trapped air in the spiral housing
- remedy: drain off the pressure tube or hose, to ensure the opening of the reflux valve to deaerate the spiral housing and ensure the correct operation of the pump

Blockage of impeller

- cause: solid- or fibrous admixtures blocking the impeller
- remedy: check impeller, as explained under „adjustment of impeller“ or „cleaning“

Reduced performance curve

- cause: clogged impeller
- remedy: clean impeller and spiral housing
- cause: worn-out impeller and / or wear plate
- remedy: change impeller and / or wear plate
- cause: wrong sense of rotation
- remedy: change two of the three mains supply leads

for UAK series

Jung Pumpen GmbH & Co Industriestraße 4-6 - 33803 Steinhagen  XX <sup>1</sup>
EN 12050-2  Abwasserhebeanlage für fäkalienfreies Abwasser DN 65  Hebewirkung – siehe technische Daten  Geräuschemissionswert < 70dB (A)  Korrosionsschutz – Kunstharzlack

<sup>1</sup> Die beiden ersten Ziffern der Pumpen-Nr. bezeichnen das Produktionsjahr.

for UFK series

Jung Pumpen GmbH & Co Industriestraße 4-6 - 33803 Steinhagen  XX <sup>1</sup>
EN 12050-1  Fäkalienhebeanlage für Gebäude DN 65  Hebewirkung – siehe technische Daten  Geräuschemissionswert < 70dB (A)  Korrosionsschutz – Kunstharzlack

<sup>1</sup> Die beiden ersten Ziffern der Pumpen-Nr. bezeichnen das Produktionsjahr.

# Operating Instructions

Picture 6: sectional drawing

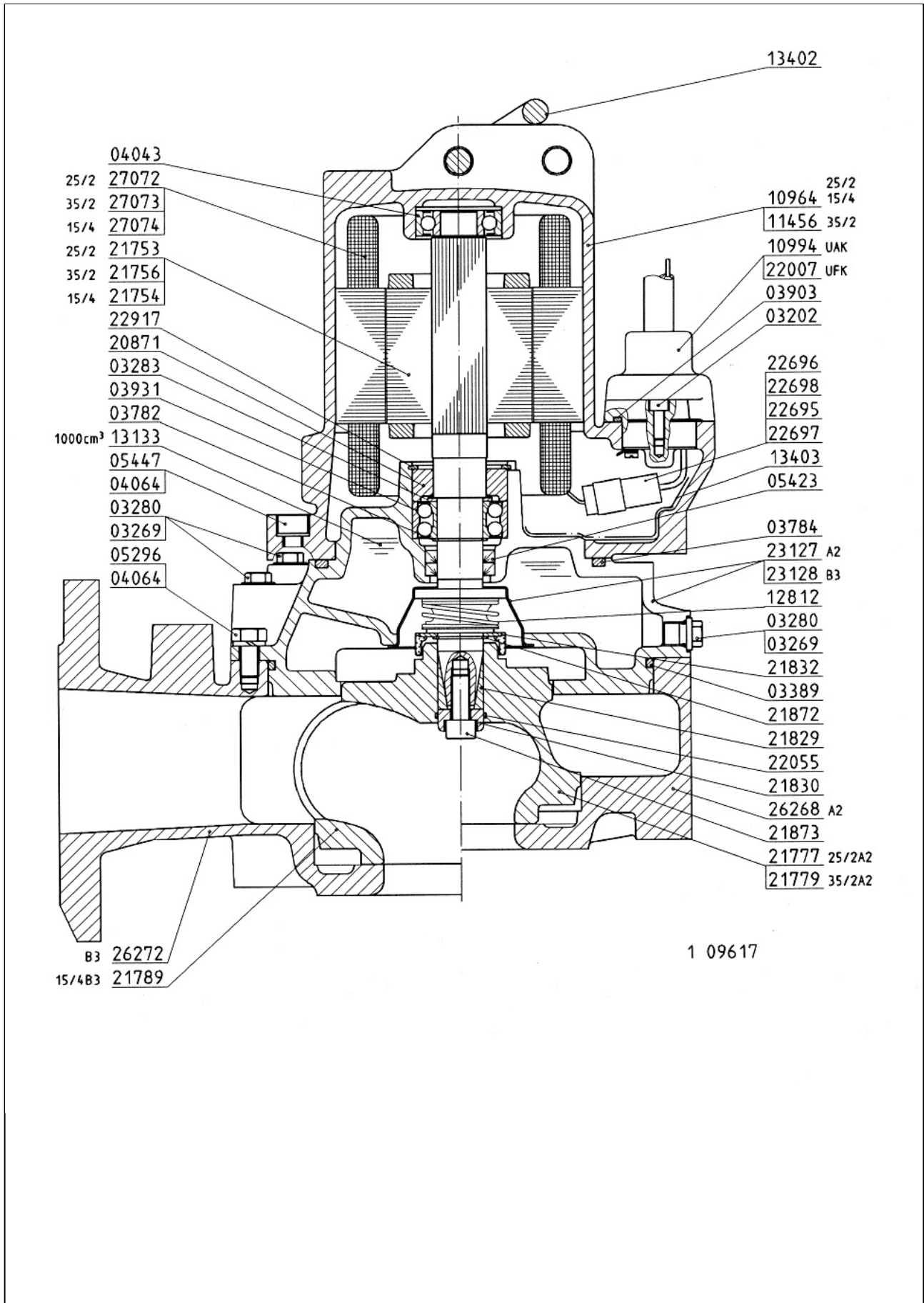

# Operating Instructions

## Spare parts list

Pos.	Code-No.	Description	UAK			UFK		
			25/2 A2	35/2 A2	15/4 B3	25/2 A2	35/2 A2	15/4 B3
1	03202	hexagon socket screw M 6 x 16	2	2	2	2	2	2
2	03269	O-ring 10 x2,5	3	3	3	3	3	3
3	03280	plug ¼", DIN 910	3	3	3	3	3	3
4	03283	supporting ring SS 25 x 35 x 2,0	1	1	1	1	1	1
5	03389	O-ring 180 x 5	1	1	1	1	1	1
6	03782	circlip for shaft A 25 x 1,2	1	1	1	1	1	1
7	03784	O-ring 142 x 6	1	1	1	1	1	1
8	03903	O-ring 38 x 3,5	1	1	1	1	1	1
9	03931	angular ball bearing 3205 B 2RSTG	1	1	1	1	1	1
10	04043	deep grooveball bearing 6204 2RSR	1	1	1	1	1	1
11	04064	split washer B 10	6	6	6	6	6	6
12	05296	hexagon head screw M 10 x 20	4	4	4	4	4	4
13	05423	rotary shaft seal 25 x 38 x7	2	2	2	2	2	2
14	05447	hexagon socket screw M 10 x 30	2	2	2	2	2	2
15	10964	stator casing 135 EB max. 75	1	1	1	1	1	1
16	10994	cable gland UAK, type A1, 10,0 m	1	1	1	-	-	-
17	11456	stator casing 135 EB	1	1	1	1	1	1
18	12812	mechanical seal 25 x 24 Q1/Q1	1	1	1	1	1	1
19	13133	oil 1000 cm³ Spinesso 22	1	1	1	1	1	1
20	13392	crimp connector	5	5	5	5	5	5
21	13402	shackle ⅝"	1	1	1	1	1	1
22	13403	insulating foil	1	1	1	1	1	1
23	20871	spacer 29 x 52 x 18	1	1	1	1	1	1
24	21753	shaft with rotor 25/2, D 90-2/75 E	1	-	-	1	-	-
25	21754	shaft with rotor 15/4, D 90-4/ 75 D	-	-	1	-	-	1
26	21756	shaft with rotor 35/2, D 90-2/ 110 C	-	1	-	-	1	-
27	21777	impeller 25/2 A2	1	-	-	1	-	-
28	21779	impeller 35/2 A2	-	1	-	-	1	-
29	21789	impeller 15/4 B3	-	-	1	-	-	1
30	21829	taper sleeve Ø 25 x 28	1	1	1	1	1	1
31	21830	thrust piece Ø 24,9 x 12	1	1	1	1	1	1
32	21832	shaft cover Ø 49 x 12,5	1	1	1	1	1	1
33	21872	circlip for shaft A 25 x 12,5	1	1	1	1	1	1
34	21873	hexagon socket screw M 10 x 25	1	1	1	1	1	1
35	22007	cable gland type A2, UFK 10,0 m	-	-	-	1	1	1
36	22055	O-ring 25 x 2	1	1	1	1	1	1
37	22695	plug housing, system con1	1	1	1	1	1	1
38	22696	sleeve housing, system con1	1	1	1	1	1	1
39	22697	round plug, system con1	6	6	6	6	6	6
40	22698	round sleeve, system con1	6	6	6	6	6	6
41	22917	tapered ring WA JB 52	1	1	1	1	1	1
42	23127	bearing housing A2	1	1	-	1	1	-
43	23128	bearing housing B3	-	-	1	-	-	1
44	26268	pump casing A2	1	1	-	1	1	-
45	26272	pump casing B3	-	-	1	-	-	1
46	27072	stator 25/2, D 90-2/75 E	1	-	-	1	-	-
47	27073	stator 35/2, D 90-2/110 C	-	1	-	-	1	-
48	27074	stator 15/4, D 90-4/75 D	-	-	1	-	-	1

## Replacement kits

11345	stator casing with stator D 90-4/75 C (10/4 B1), consisting of 10964, 27074, 13403
11346	stator casing with stator D 90-2/75 C (10/2 A1, 15/2 A1, 25/2 B1), consisting of 10964, 27072, 13403
14999	oil, Spinesso 22, 1 Liter bottle
22032	seal kit, consisting of: 03269, 03389, 03784, 03903, 05423, 12812, 21832, 22055

By ordering spare parts indicate type of the pump and the part number.