

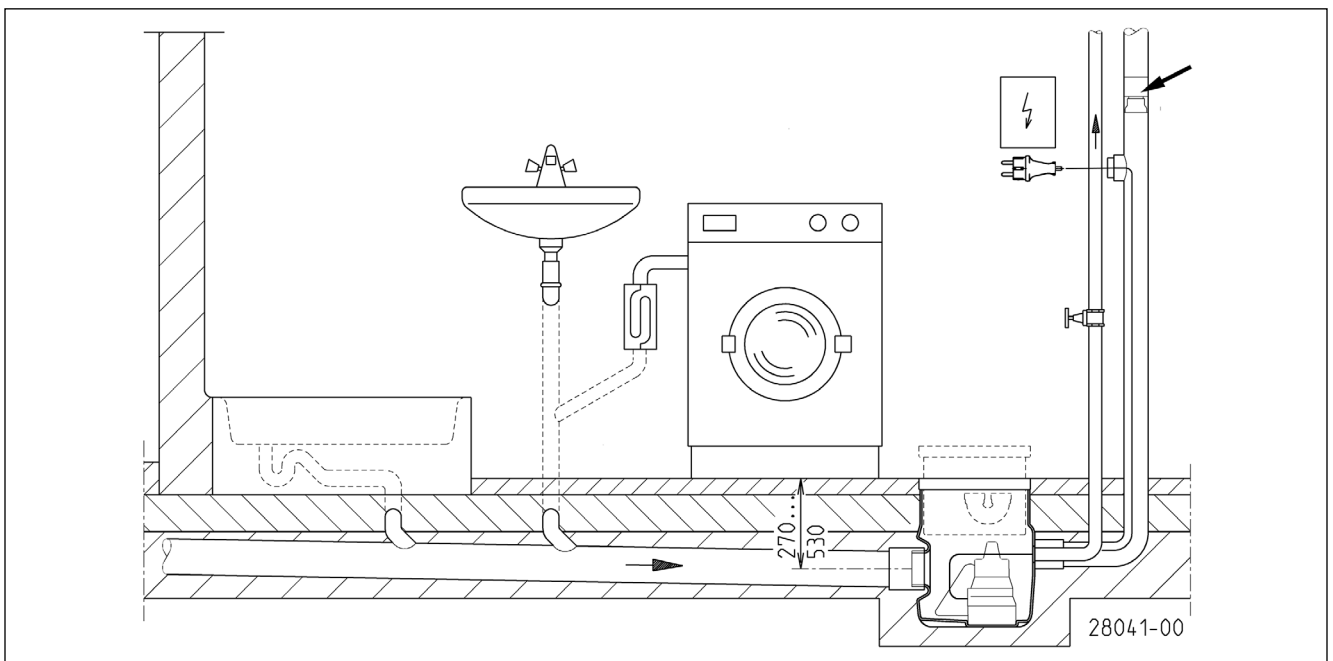

# BAUFIX 50

EN Instruction Manual

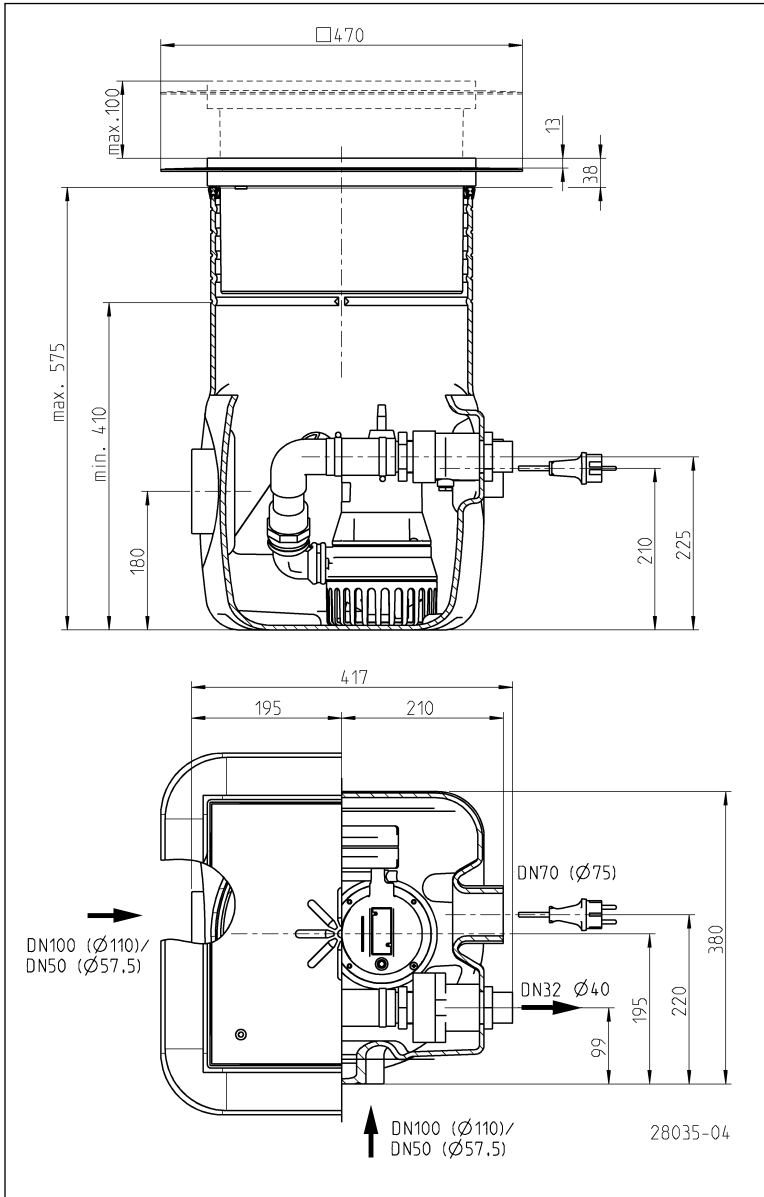



You have purchased a product made by Pentair Jung Pumpen and with it, therefore, also excellent quality and service. Secure this service by carrying out the installation works in accordance with the instructions, so that our product can perform its task to your complete satisfaction. Please remember that damage caused by incorrect installation or handling will adversely affect the guarantee. Therefore please adhere to the instructions in this manual!

This appliance can be used by children aged 8 years or over and by persons with limited physical, sensory or intellectual capabilities, or with limited experience and knowledge, provided that they are supervised or have been instructed in the safe use of the appliance and are aware of the dangers involved. Children must not be allowed to play with the appliance. Cleaning and user maintenance must not be carried out by children unless they are supervised.

**Damage prevention in case of failure**

Like any other electrical device, this product may fail due to a lack of mains voltage or a technical defect.

If damage (including consequential damage) can occur as a result of product failure, the following precautions can be taken at your discretion:

- Installation of a water level dependent (under circumstances, mains-independent) alarm system, so that the alarm can be heard before damage occurs.
- Inspection of the collecting tank/chamber for tightness up to the top edge before – or at the latest, during – installation or operation of the product.
- Installation of backflow protection for drainage units that can be damaged by wastewater leakage upon product failure.
- Installation of a further product that can compensate in case of failure of the other product (e.g. duplex unit).
- Installation of an emergency power generator.

As these precautions serve to prevent or minimise consequential damage upon product failure, they are to be strictly observed as the manufacturer's guideline – in line with the standard DIN EN specifications as state of the art – when using the product (Higher Regional Court Frankfurt/Main, Ref.: 2 U 205/11, 06/15/2012).

## SAFETY INSTRUCTIONS

This instruction manual contains essential information that must be observed during installation, operation and servicing. It is therefore important that the installer and the responsible technician/operator read this instruction manual before the equipment is installed and put into operation. The manual must always be available at the location where the pump or the plant is installed.

Failure to observe the safety instructions can lead to the loss of all indemnity.

In this instruction manual, safety information is distinctly labelled with particular symbols. Disregarding this information can be dangerous.



General danger to people



Warning of electrical voltage

**NOTICE!** Danger to equipment and operation

**Qualification and training of personnel**

All personnel involved with the operation, servicing, inspection and installation of the equipment must be suitably qualified for this work and must have studied the instruction manual in depth to ensure that they are sufficiently conversant with its contents. The supervision, competence and areas of responsibility of the personnel must be precisely regulated by the operator. If the personnel do not have the necessary skills, they must be instructed and trained accordingly.

**Safety-conscious working**

The safety instructions in this instruction manual, the existing national regulations regarding accident prevention, and any internal working, operating and safety regulations must be adhered to.

**Safety instructions for the operator/user**

All legal regulations, local directives and safety regulations must be adhered to.

The possibility of danger due to electrical energy must be prevented.

Leakages of dangerous (e.g. explosive, toxic, hot) substances must be discharged such that no danger to people or the environment occurs. Legal regulations must be observed.

**Safety instructions for installation, inspection and maintenance works**

As a basic principle, works may only be carried out to the equipment when it is shut down. Pumps or plant that convey harmful substances must be decontaminated.

All safety and protection components must be re-fitted and/or made operational immediately after the works have been completed. Their effectiveness must be checked before restarting, taking into account the current regulations and stipulations.

**Unauthorised modifications, manufacture of spare parts**

The equipment may only be modified or altered in agreement with the manufacturer. The use of original spare parts and accessories approved by the manufacturer is important for safety reasons. The use of other parts can result in liability for consequential damage being rescinded.

**Unauthorised operating methods**

The operational safety of the supplied equipment is only guaranteed if the equipment is used for its intended purpose. The limiting values given in the "Technical Data" section may not be exceeded under any circumstances.

**Instructions regarding accident prevention**

Before commencing servicing or maintenance works, cordon off the working area and check that the lifting gear is in perfect condition.

Never work alone. Always wear a hard hat, safety glasses and safety shoes and, if necessary, a suitable safety belt.

Before carrying out welding works or using electrical devices, check to ensure there is no danger of explosion.

People working in wastewater systems must be vaccinated against the pathogens that may be found there. For the sake of your health, be sure to pay meticulous NOTICE to cleanliness

wherever you are working.

Make sure that there are no toxic gases in the working area.

Observe the health and safety at work regulations and make sure that a first-aid kit is to hand.

In some cases, the pump and the pumping medium may be hot and could cause burns.

For installations in areas subject to explosion hazards, special regulations apply!

## USE

The sump is a conventional effluent collecting pit in conjunction with a separately ordered U3 KS or U3 KS special.

**NOTICE!** Due to the space saving tank design the U3 KS or the U3 KS can only be operated with the low level float which is part of the extent of delivery

**NOTICE!** The connection between the sump and the concrete can not be sealed against pressing water. Do not install the sump in areas with high groundwater levels!

**NOTICE!** In some countries it must not be used for pumping sewage water from lavatories.

The allowed temperature of the pumped medium is 35 °C, short time period 60°C.

The screwed cover is smell-tight and level compensating. The integrated and smell-tight floor drain can be opened on request.

The PE-tank has two collateral inlet sockets DN 100, offset by 90°, one discharge socket for Ø 40 mm PVC pipe and a vent socket DN70. The tank neck with its adjustable and rotatable cover allows an optimized level compensation at the building site.

### Extent of delivery

Underground sump Baufix 50 pre-assembled with male threaded pressure outlet, non-return valve 1 1/4", nipple 40-1 1/4", cover frame with seal, lid with sealing plug usable as a grommet, pipework, low level float, hose clamp with snap buckle; profiled seal, hose clamp 1 1/2" DN 40; siphon, elastic connection and plug-in seals

### Electrical Connection

Please refer to the relevant instructions in the manual for the pump.

## MOUNTING

The pressure tube must be taken in a loop over the local back-pressure level and secured with a reflux valve. (EN 12056) The reflux valve is already installed in the BAUFIX 50.

### Tank installation

1. Take the parts out of the tank. Do not dismantle the pre-assembled pipework or the reflux valve, because they are already sealed.
2. Saw off the tank neck in the required height along the marked grooves.
3. Push the profile packing with its clamping groove on the edge of the tank opening. The lips of the seal must be di-

rected to the inside. Grease the seal and push the frame a little bit declined into the opening. Then adjust it and push the frame into the opening completely, up to the desired position (final floor height). The air will escape audible out of the seal. If the seal is rolled up, the installation must be repeated.

4. Open the required sockets for the inlet and the ventilation at the marked positions with a saw or a knife and remove the burr. Connect the inlet and the ventilation pipes with KG-sleeves. The pressure pipe must be glued with a PVC sleeve onto the pressure outlet.
5. After connection of all pipes, the BAUFIX 50 must be levelled and washed in. Do not remove the cover during the installation to keep the tank clean.
6. At concreting the base, the tank can be secured against buoyancy by reinforcing steel at the welded wire mesh.
7. Do not embed the frame in concrete. It should stay adjustable to compensate floor pavements or tiles up to 100 mm.
8. Before carrying out the flooring works adjust the frame in the planed position and fasten it.
9. To allow a wetroom seal to be fitted, the top surface of the screed must finish flush with the top edge that runs all round the cover frame.
10. After the screed has set, the enclosed square seal is bonded to the integrated sealing strip. After the customer has attached a further thin-bed waterproofing system, the area can be tiled. **Information** on sealants and adhesives can be found in the information sheet on "Composite sealing" issued by the professional association of the German tile industry within the German Construction Confederation (ZDB).

### Pump installation

1. Seal the pump quarter elbow with Teflon strap and screw it on the discharge branch.
2. Seal the thread of the pre-assembled pipework with Teflon strap, screw it in the quarter elbow of the pump and adjust it as shown below.
3. Unscrew the standard float at the control shaft, replace it by the low level float and fasten it again with the sheet metal screw.
4. Push the elastic connector up to the end on the pipework and fasten it with a hose clamp.
5. Push the hose clamp with the snap buckle on the flexible connector. Insert the pump in the tank and push the flexible connector on the reflux valve. Fasten it with the hose clamp. **NOTICE!** Ensure the stable position of the pump as well as the free movement of the float switch!
6. Pull the cable up to the T-piece through the vent pipe. Enough cable has to be in the tank to allow the pump to be pulled out of the tank for servicing. The T-piece can then be sealed with the slotted plug.

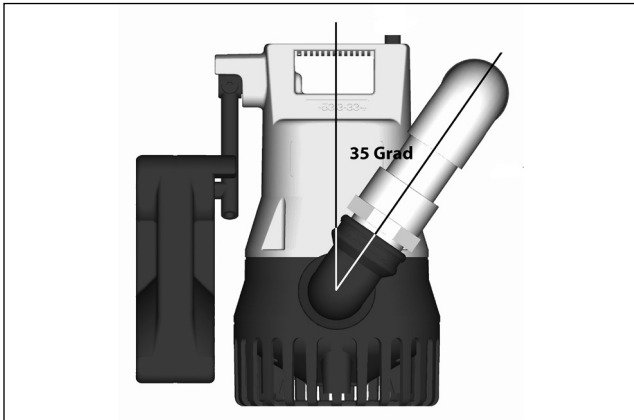

## MAINTENANCE

The tank, the float switches and the foot strainer of the pump should be inspected regularly and cleaned if necessary.

To service the pump, please refer to the separate operating instruction.

**NOTICE!** Always grease the screws before using them to close the cover plate and ensure the correct position of the profiled seal.

### Installation of floor drain

1. Take out the 2 screws of the cover plate and remove it.
2. Take the plug out of the cover connection piece with a screwdriver.
3. Screw the siphon with the union nut, the packing and the expanding ring on the connection piece.
4. The outlet of the siphon must not be positioned directly above the pump.
5. At using the stainless steel frame, grease the screws and screw down the cover plate again.

### Accessory alarm device

The alarm device signals an excessive high water level. It can be installed subsequently. The cable is pulled through the vent pipe and sealed in the same way as the pump cable. The alarm unit should be connected to a separate electric circuit, to ensure the operation in case of a pump fault. Alternatively it can be equipped with our 9V-rechargeable battery for off the line operation.

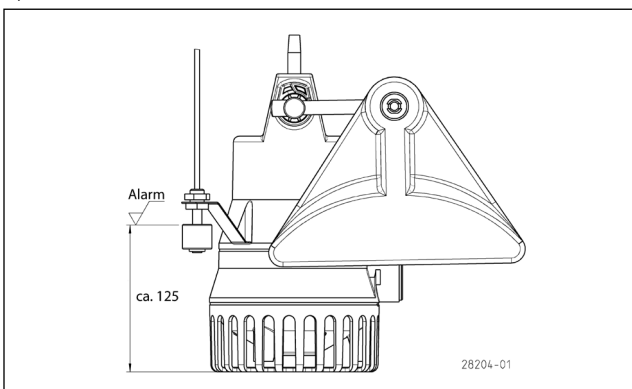

### Accessory special ventilation

If the ventilation over the roof level is not possible, alternatively the special ventilation consisting of a ventilation screen and 3 activated carbon filters can be installed with a T-piece in the cable pipe.



## BAUFIX 50 (JP09335)

Spare parts

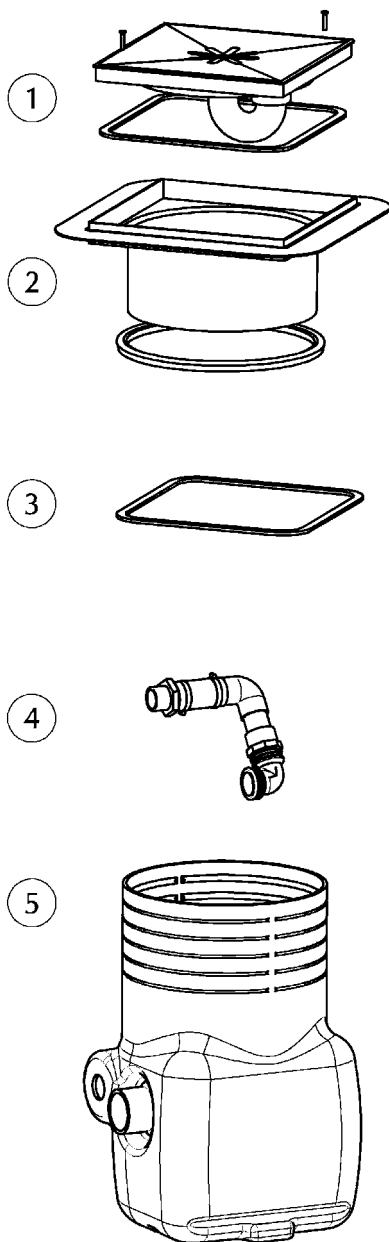

①	Abdeckplatte	Cover	<b>JP48245</b>
②	Abdeckrahmen	Frame	<b>JP48244</b>
③	Dichtprofil	Profiled joint	<b>JP47394</b>
④	Anschluss-Set	Connecting kit	<b>JP47395</b>
⑤	Behälter	Sump	<b>JP47393</b>

BAUFIX 100 (JP47214)



**PUMP TECHNICAL SERVICES LIMITED**



**JUNG PUMPEN**