

# COMPLI 500

## SEWAGE LIFTING STATIONS

- Ready to connect
- Submersible
- Clamp-type inlet flange
- Versatile connection facilities
- PE-tank 117 l
- Vortex impeller
- With mounted swing-type check valve
- Smart Home capable



### DESCRIPTION

With its performance graduations, the compli 500 lifting station has been designed for use in detached houses with increased domestic waste-water inlet and for a larger storage capacity. During the design work, special attention was given to easy handling (weight !), space-saving erection and uncomplicated installation.

The submersible unit is permitted for general use in areas subject to flooding. The control unit has to be fitted in a well ventilated flood-proof room.

The PE tanks has freely accessible drains, a cleaning opening at the top and a clamp-type inlet flange for an easy installation.

The inlet height can be variegated according to the feeding pipe:

DN100: 180-205 mm (left), 250-300 mm (center) and 290-340 mm (right), each continuously adjustable; DN150/DN 50: 180 mm (left), 275 mm (center) and 315 mm (right)

For the connection of a DN 100 feeding pipe a reducer DN 150/100 is enclosed. The tank has vertical inlet in DN 150 or DN 100. If not in use, the rear inlet must be closed with the plug set DN 150 (accessory).

The vortex impeller of the pump offers the safety you can rely on.

The compli sewage lifting station can be integrated into a smart infrastructure. The FTJP radio transmitter is connected to the potential-free contact of the lifting station. It is now possible to transmit the switching status (e.g. an alarm message) to an EnOcean-capable smart home gateway (Wibutler, Afriso, Homee).

### PERFORMANCE

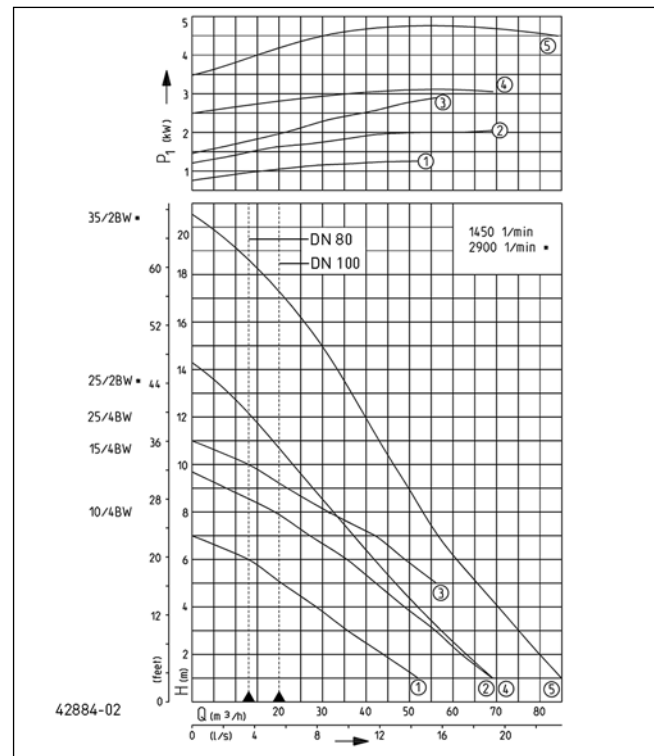

Type	Delivery head H [m]	1	2	3	4	5	6	7	8	9	10	11	13	15	17
complli 510/4 BW	Flow rate Q [m³/h]	52	44	37	29	22	13								
complli 515/4 BW		69	62	56	49	42	36	27	19						
complli 525/4 BW						56	49	42	32	22	13				
complli 525/2 BW		69	64	58	52	47	42	37	33	28	23	20	8		
complli 535/2 BW		85	80	75	71	66	62	57	54	50	47	44	36	30	21

We reserve the right to change specifications without notice. Pump performance is subject to ISO 9906 tolerances

The minimum flow velocity in the pressure piping must be 0.7 m/s according to EN 12056. This data is represented in the performance curve as a limit of application.



# COMPLI 500

## SEWAGE LIFTING STATIONS

### SCOPE OF SUPPLY

Ready for plug in sewage lifting unit according to EN 12050-1 with clamp flange DN 150, reducer DN 150/100, built-on subm. sewage pump and connection flange DN 80 with pipe socket Ø 110 mm, with mounted swing-type check valve, elastic connection c/w hose clamps, PVC collar DN 70 for ventilation connection, autom. level controller, control unit (IP 44) c/w motor

protection, motor contactor, transformer, mains-dependent alarm unit and potential-free contact for collective failure messages, with optical display of sense of rotation, alarm and operation, and manual-0-automatic switch.

Cable between tank and control 4 m, cable between control and plug 1.5 m.

### MECHANICAL DATA

Pump	Vertical single-stage	Motor housing	Grey cast iron
Free passage	70 mm	Pump housing	Grey cast iron
Pressure pipe	DN 100	Submersible	Yes
Bearing	Ball bearings, grease-lubricated	Pressure outlet	DN 80
Impeller	Vortex impeller, grey cast iron	Tank capacity	117 l

### ELECTRICAL DATA

Voltage	3/N/PE~400 V	Insulation class	F
Power line	4m H07RN-F	Winding thermostat	Yes
Wires	6G1,5	Plug	CEE-16A
Type of enclosure	IP 68		

### COMPLI 500

Type	Code No.	Motor rating		Current	Oil chamber	Weight
		P1	P2			
compl 510/4 BW	<b>JP09191</b>	1.3 kW	1.0 kW	2.8 A	No	79 kg
compl 515/4 BW	<b>JP09192</b>	2.2 kW	1.7 kW	3.9 A	No	79 kg
compl 525/4 BW	<b>JP09193</b>	3.0 kW	2.2 kW	5.1 A	No	79 kg
compl 525/2 BW	<b>JP09194</b>	3.3 kW	2.6 kW	5.4 A	Yes	86 kg
compl 535/2 BW	<b>JP09195</b>	4.8 kW	4.0 kW	8.2 A	Yes	89 kg

# COMPLI 500

## SEWAGE LIFTING STATIONS

### Dimensions compli 500 (mm)

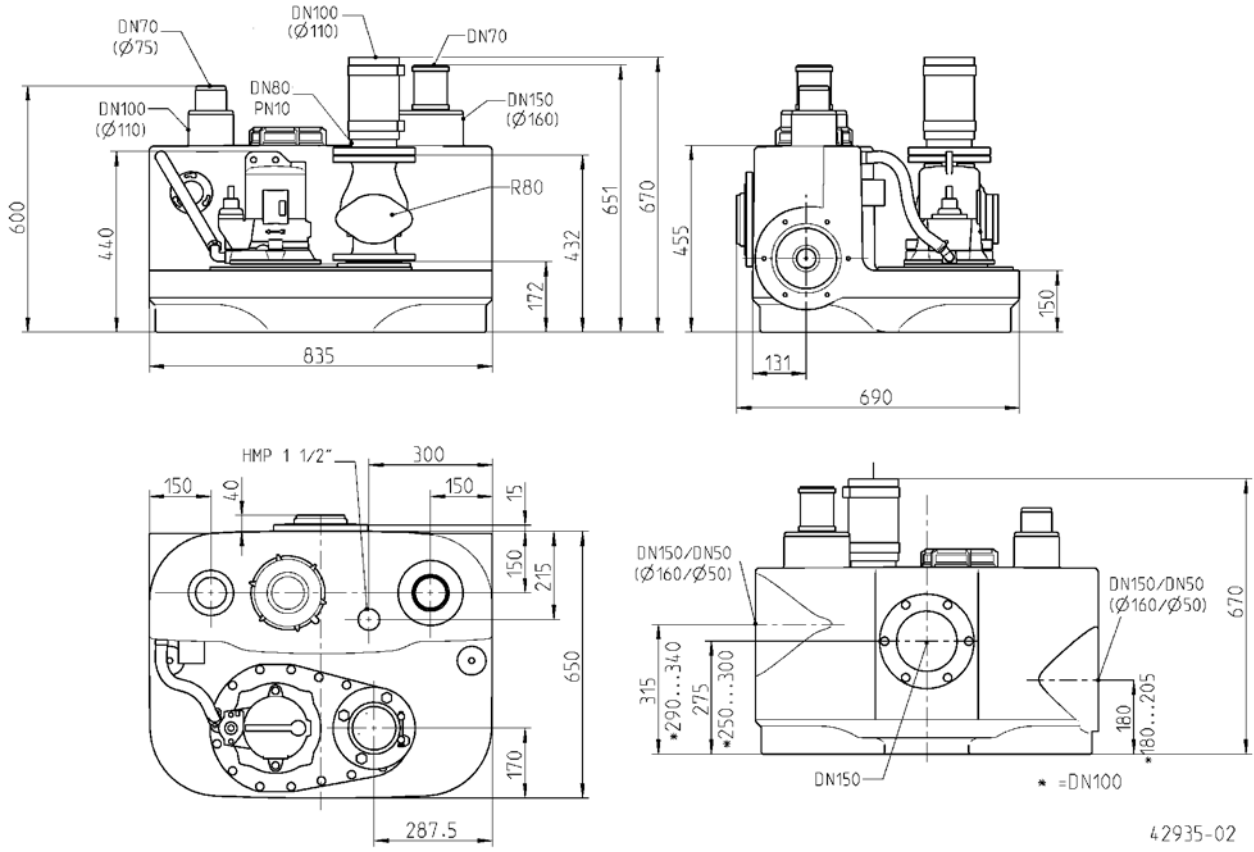

### Example of installation

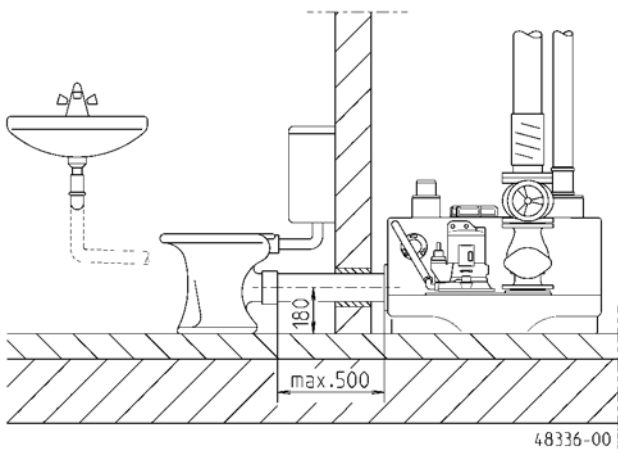

### Example of installation

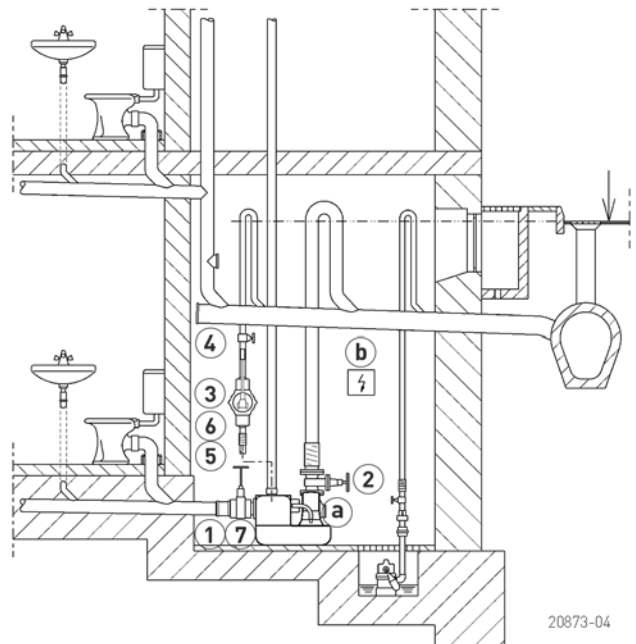



# COMPLI 500

## SEWAGE LIFTING STATIONS

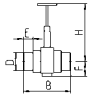
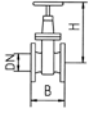
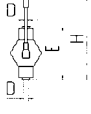
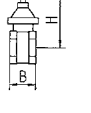
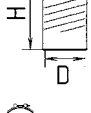

All types have DN 80 / PN 10 connecting flange, however with pipe socket DN 100. For this reason, a non-return valve for the pressure pipe need to be chosen for DN 80 only in case of direct erection. The ownstream pressure pipe is connected to DN 100 by an elastic connection. Sewage lifting stations are to be used for the transport of faecal matter and domestic wastewater in building drainage systems as described in German standard DIN 1986 T3. In keeping with the stipulations of German / European standard EN 12056-4 they

have to be mounted with collecting tanks inside building permitting a free space of 60 cm for operation and repair. The pressure pipe has to be passed above the locally defined backpressure level and a non-return valve tested in keeping with German / European standard 12050-4 has to be mounted. In keeping with German / European standard 12056 the ventilation pipe has to be passed up to the roof. EN 12056 paragraph 5.1 In applications where the waste-water inlet must not be interrupted a double system has to be installed.

### MECHANICAL ACCESSORY

				Code No.
	<b>① Inlet gate valve PVC</b>	with two pipe sockets, DN 100, PN1	360x295 (HxW)	<b>JP28297</b>
		with two pipe sockets, DN 150, PN2.5	660x450 (HxW)	<b>JP28591</b>
	<b>② Sluice valve</b>	DN 80, PN 10, EN 1171	315x180 (HxB)	<b>JP00639</b>
	<b>③ Hand diaphragm pump</b>	for emergency purposes (up to H geod 15 m)	640x1½" (HxD)	<b>JP00255</b>
	<b>④ Stop valve</b>	brass, 1½" (DN 40), PN 16	125x60 (HxB)	<b>JP44786</b>
	<b>⑤ Elastic connection</b>	1½" (DN 40), PN 4	120x50 (HxD)	<b>JP44777</b>
	<b>⑥ Hose band clamp</b>	1½"		<b>JP44763</b>
	<b>⑦ Opening set</b>	DN 150, required for lateral connection		<b>JP43156</b>

### ELECTRICAL ACCESSORY

				Code No.
	<b>a Seal leak detector</b>	DKG		<b>JP44900</b>
	<b>b Rechargeable battery</b>	for mains independent alarm		<b>JP44850</b>