

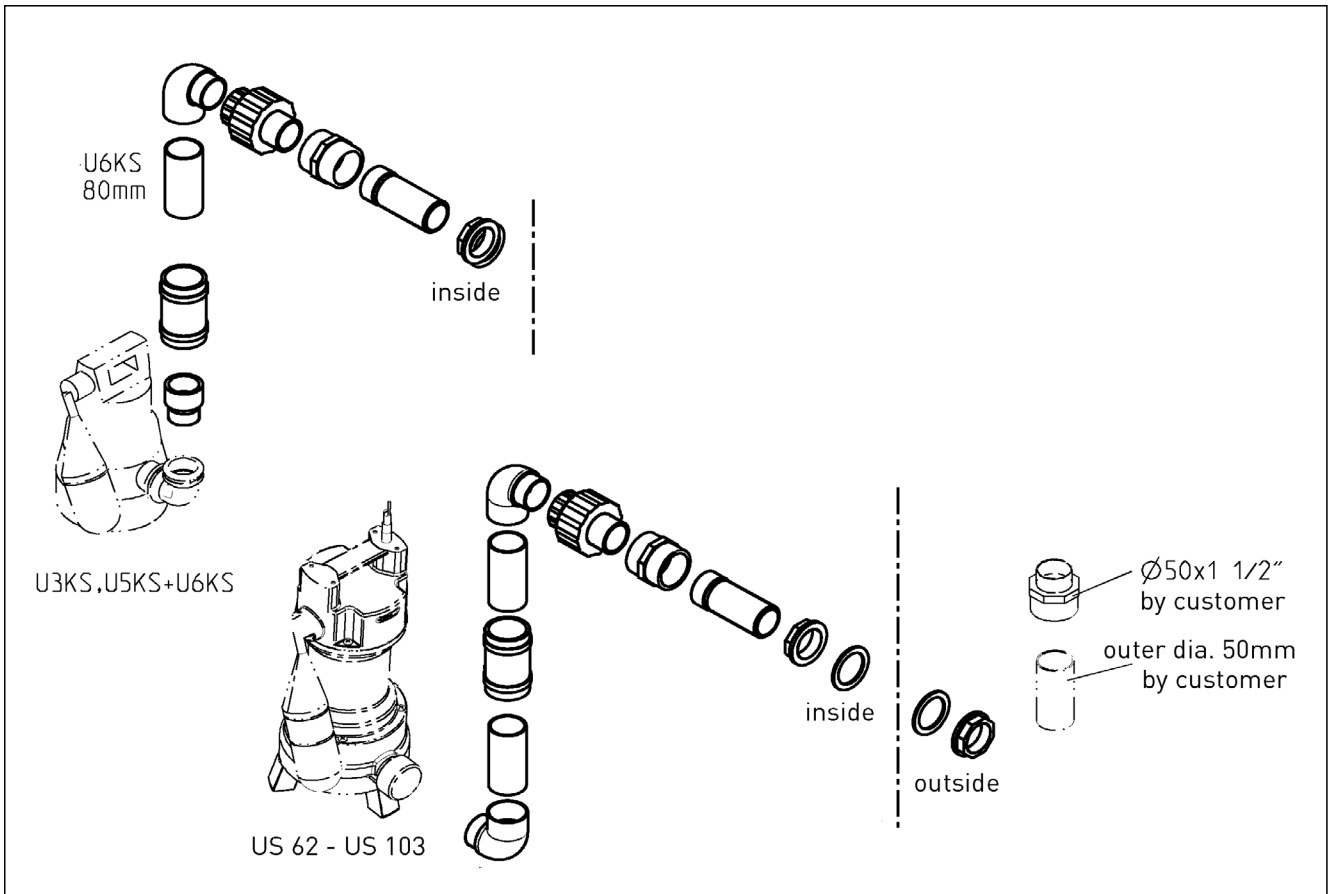

HEBEFIX 100

EN Instruction Manual

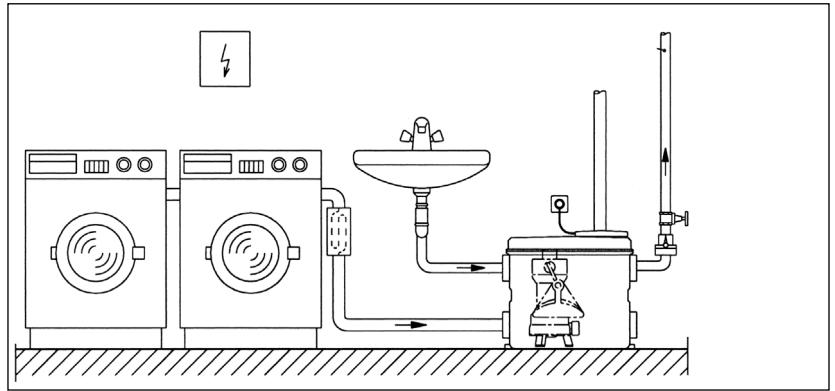

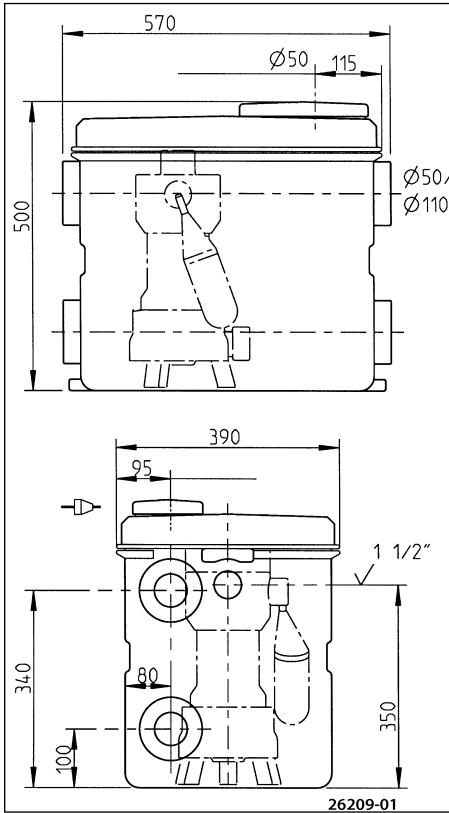

You have purchased a product made by Pentair Jung Pumpen and with it, therefore, also excellent quality and service. Secure this service by carrying out the installation works in accordance with the instructions, so that our product can perform its task to your complete satisfaction. Please remember that damage caused by incorrect installation or handling will adversely affect the guarantee. Therefore please adhere to the instructions in this manual!

This appliance can be used by children aged 8 years or over and by persons with limited physical, sensory or intellectual capabilities, or with limited experience and knowledge, provided that they are supervised or have been instructed in the safe use of the appliance and are aware of the dangers involved. Children must not be allowed to play with the appliance. Cleaning and user maintenance must not be carried out by children unless they are supervised.

Damage prevention in case of failure

Like any other electrical device, this product may fail due to a lack of mains voltage or a technical defect.

If damage (including consequential damage) can occur as a result of product failure, the following precautions can be taken at your discretion:

- Installation of a water level dependent (under circumstances, mains-independent) alarm system, so that the alarm can be heard before damage occurs.
- Inspection of the collecting tank/chamber for tightness up to the top edge before – or at the latest, during – installation or operation of the product.
- Installation of backflow protection for drainage units that can be damaged by wastewater leakage upon product failure.
- Installation of a further product that can compensate in case of failure of the other product (e.g. duplex unit).
- Installation of an emergency power generator.

As these precautions serve to prevent or minimise consequential damage upon product failure, they are to be strictly observed as the manufacturer's guideline – in line with the standard DIN EN specifications as state of the art – when using the product (Higher Regional Court Frankfurt/Main, Ref.: 2 U 205/11, 06/15/2012).

SAFETY INSTRUCTIONS

This instruction manual contains essential information that must be observed during installation, operation and servicing. It is therefore important that the installer and the responsible technician/operator read this instruction manual before the equipment is installed and put into operation. The manual must always be available at the location where the pump or the plant is installed.

Failure to observe the safety instructions can lead to the loss of all indemnity.

In this instruction manual, safety information is distinctly labelled with particular symbols. Disregarding this information can be dangerous.



General danger to people



Warning of electrical voltage

NOTICE! Danger to equipment and operation

Qualification and training of personnel

All personnel involved with the operation, servicing, inspection and installation of the equipment must be suitably qualified for this work and must have studied the instruction manual in depth to ensure that they are sufficiently conversant with its contents. The supervision, competence and areas of responsibility of the personnel must be precisely regulated by the operator. If the personnel do not have the necessary skills, they must be instructed and trained accordingly.

Safety-conscious working

The safety instructions in this instruction manual, the existing national regulations regarding accident prevention, and any internal working, operating and safety regulations must be adhered to.

Safety instructions for the operator/user

All legal regulations, local directives and safety regulations must be adhered to.

The possibility of danger due to electrical energy must be prevented.

Leakages of dangerous (e.g. explosive, toxic, hot) substances must be discharged such that no danger to people or the environment occurs. Legal regulations must be observed.

Safety instructions for installation, inspection and maintenance works

As a basic principle, works may only be carried out to the equipment when it is shut down. Pumps or plant that convey harmful substances must be decontaminated.

All safety and protection components must be re-fitted and/or made operational immediately after the works have been completed. Their effectiveness must be checked before restarting, taking into account the current regulations and stipulations.

Unauthorised modifications, manufacture of spare parts

The equipment may only be modified or altered in agreement with the manufacturer. The use of original spare parts and accessories approved by the manufacturer is important for safety reasons. The use of other parts can result in liability for consequential damage being rescinded.

Unauthorised operating methods

The operational safety of the supplied equipment is only guaranteed if the equipment is used for its intended purpose. The limiting values given in the "Technical Data" section may not be exceeded under any circumstances.

Instructions regarding accident prevention

Before commencing servicing or maintenance works, cordon off the working area and check that the lifting gear is in perfect condition.

Never work alone. Always wear a hard hat, safety glasses and safety shoes and, if necessary, a suitable safety belt.

Before carrying out welding works or using electrical devices, check to ensure there is no danger of explosion.

People working in wastewater systems must be vaccinated against the pathogens that may be found there. For the sake of your health, be sure to pay meticulous attention to cleanliness wherever you are working.

Make sure that there are no toxic gases in the working area.

Observe the health and safety at work regulations and make

sure that a first-aid kit is to hand.

In some cases, the pump and the pumping medium may be hot and could cause burns.

For installations in areas subject to explosion hazards, special regulations apply!

USE

The Hebefix 100 tank is a drainage pump station which can be equipped with the pumps U3KS, U3KS spezial, U5KS, U6K ES+DS, US 62 up to US 103 ES+DS. The operating conditions according to the manual of the pump must be observed.

CAUTION! The Hebefix is designed for usual domestic drainage water, according to EN 12056. In some countries it must not be used for pumping sewage water from lavatories.

The allowed temperature of the pumped medium is 35° C (short time period 60° C).

The Hebefix 100 has 4 lateral marked connection branches on both sides for tubes with Ø 50 mm or Ø 110 mm to connect a wash basin, a washing machine or a dishwasher. In connection with a special float a shower can be connected as well. The pressure tube can be installed right or left handed through the upper connection pieces of the tank casing. The marked opening has to be drilled at site.

The tank is serially fitted with a ventilation valve in the lid, which closes with rising water level. If the marked connection in the cover will be opened, the vent pipe to the roof can be connected from the top. Alternatively it can be connected at the side, in this case, ventilation valve can be closed with the closing plug Ø22,3.

Ventilation.

Sumps and tanks for the drainage of a cellar should be covered and, if necessary, specially ventilated (EN 12056).

Ventilations with additional activated carbon filters decrease annoyance caused by bad smell.

Extent of delivery

Above ground tank Hebefix 100 (tank with sealed screwed lid), 1 hose clamp, 2 fillister head screws, 3 cap screws, 3 caps (black), 1 ball Ø 25,4 mm, socket plug DN 50, 1 ventilation seal, 1 plug-in seal d 50 x D59, 1 activated carbon filter, 1 closing plug.

Bag with: bushing 50x1 1/2", 2 octagon nuts, 2 PE-bearing rings, threaded bushing, connection joint, 2 elbows 90°, 2 pipes ø 50x100, elastic connection 1 1/2", 2 hose clamps 1 1/2", bushing 40x 1 1/4", 4 plug-in seals d50 x D59, closing plug Ø22,3, 2 wood screws, 2 washers 2 plugs, 2 fastening clamps, 2 fillister head screws.

Bag with : 1 non-return valve DN 40, 1 collar DN 100, 2 hose clamps 4", 1 manual.

ELECTRICAL CONNECTION

Please pay attention to the operating instructions of the installed pump.

MOUNTING

The installation of the lifting unit should be made in accordance to the guide lines for faeces free sewage EN 12056-4. The tank must be easily accessible for maintenance and service. The installation must guarantee the reliable operation.

The Hebefix 100 should be installed as shown at the end of the manual. In accordance to EN 12056 the pressure pipe must be taken in a loop over the local back-up level and secured with a reflux valve. The reflux valve 1 1/2 inch (Z-53.4-369) is enclosed. Each drain connection (e.g. washing machine, dish washer ...) must have a siphon trap.

Installation

1. Take the plugs and the screws out of the cable cover. Remove the cover itself. Seize into the recessed grips, lift the cover off the tank and withdraw the accessories.

U3KS, U5KS and U6KS: Screw the 1 1/4" plastic elbow (extend of pump unit) with sealing tape handtight onto the pressure branch of the pump. Screw the reducing nipple 40 x 1/4" into the elbow.

US 62 bis US 103 ES+DS: Screw one of the 1 1/2" plastic elbow with pipe piece Ø 50 x 100 with sealing tape into the pressure branch of the pump.

Next, component follows the elastic connection. For the further pressure pipe construction see drawing page 2.

2. Open the required connection pieces for the pressure outlet, the inlet(s) and if required for the ventilation at the marked points, by cutting or drilling.

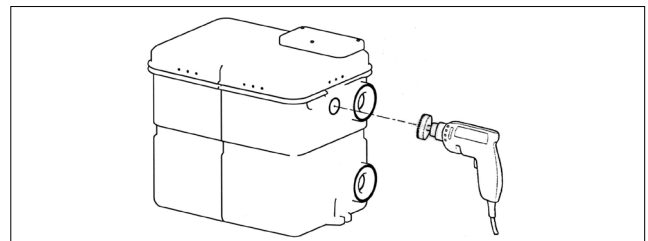

CAUTION! Do not damage the raised and flat face ! and push the enclosed plug-in seals into the opened connection branches.

Connection of the inlet pipe DN 100: connect the spigot end of the DN 100 pipe with the elastic connection DN 100 and the 2 hose clamps 4" to the required tank socket. For additional connections in DN 100 elastic connections and hose clamps are available as accessories.

3. Put the pump with the pressure pipework into the floor lock of the tank and push the pressure tube through the bore hole. Fasten the pipework with the 1 1/2" octagon nut from outside. The tank can now be connected with the external pipework.

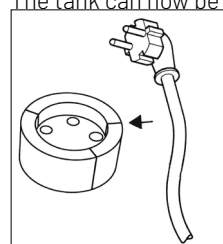

4. Pull the pump cable with the plug through the Ø 70 mm hole in the cover. Swing open the seal plug, insert the pump cable and push the plug into the provided hole in the cover. The cable in the tank must be so short that the float moves free. For the outer cable length think about the installation of the cover and necessary maintenance.

5. Remove and **unwrapp** the activated carbon filter and put it over the ventilation hole between the terminal plates. In case of ventilation to the roof press the enclosed plug into the ven-

tilation hole of the lid.

6. Press the cover over the tank edge until the snap connections click into place. Fix the cable(s) with the clips and the screws. Screw down the cover with the screws and cover them with the plugs. Now the Hebefix is ready for service.

Mounting special float (accessory)

The special float (JP 44795 or JP44207) for the pump is required for dewatering a shower tray. A shower can be connected only in conjunction with a dewatering pump U3KS, U5KS or U6KS. To prevent a backpressure of water into the shower tub, observe the min. shower installation height.

In connection with a US pump type the special float allows to lower the switch levels, e.g. for washingmachines.

Mounting automatic alarm (accessory)

The automatic alarm AGR (JP44893) or the alarm AWR (JP44897) signalizes an unacceptably high water level. The AWR simultaneously turns off the connected washing machine or dishwasher.

Open the marked position in the cover \varnothing 13 mm and mount the alarm switch corresponding to the operation instructions.

The installation of a U3KS, U5KS and U6KS with a low level switch requires, the fastener (JP28191) for the alarm unit.

MAINTENANCE



WARNING!

Before every work on the pump: pull main plug!

The unit is free of maintenance. In case of a deteriorate pump performance remove all sediments from the tank.

For pump maintenance see manual of the pump.

Change of the activated carbon filter

- 1x year at least
- in case of annoyance caused by bad smell
- in case of water penetration through the filter.



HEBEFIX 100 (JP09319)

Spare parts

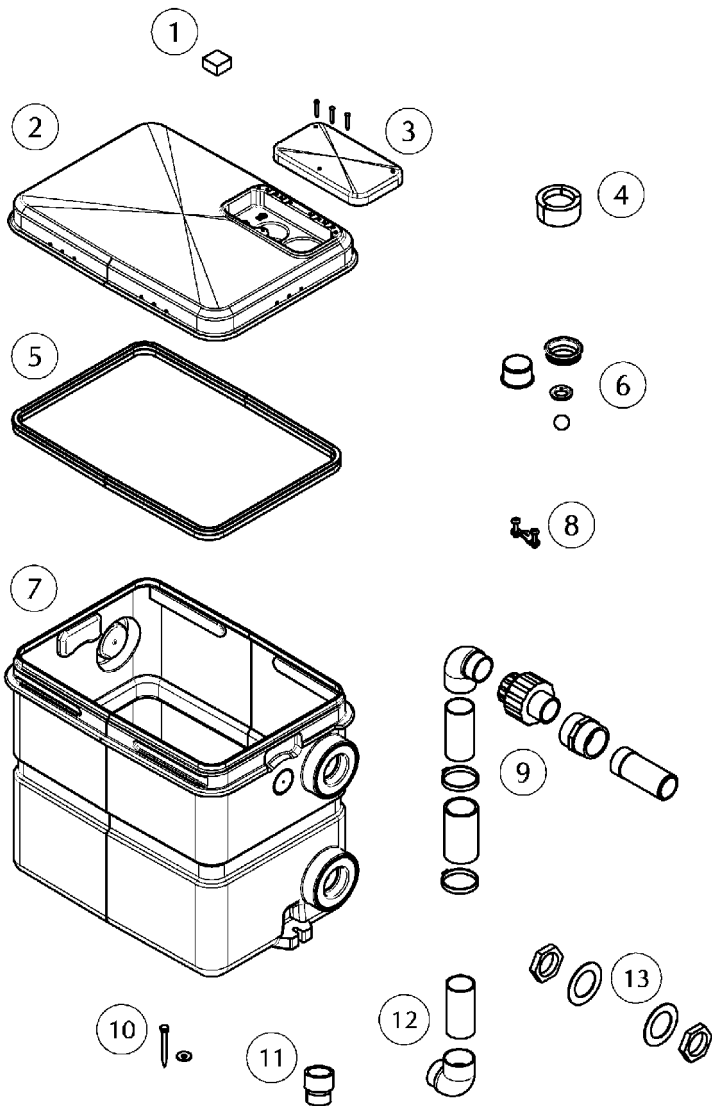

①	Filter	Filter	JP47542
②	Deckel	Cover	JP47545
③	Abdeckung	Cap	JP47547
④	Verschlussstopfen	Sealing plug	JP47550
⑤	Deckeldichtung	Cover seal	JP47546
⑥	Lüftung	Ventilation	JP47548
⑦	Behälter	Tank	JP47544
⑧	Befestigungsschelle	Mounting clamp	JP47549
⑨	Anschluss-Set	Connecting kid	JP47552
⑩	Auftriebssicherung	Buoyancy control	JP47555
⑪	Anschluss U3-U6	Connection U3-U6	JP47553
⑫	Anschluss US	Connection US	JP47554
⑬	Wanddurchführung	Wall duct	JP47559



HEBEFIX 100 H (JP09348)
Spare Parts

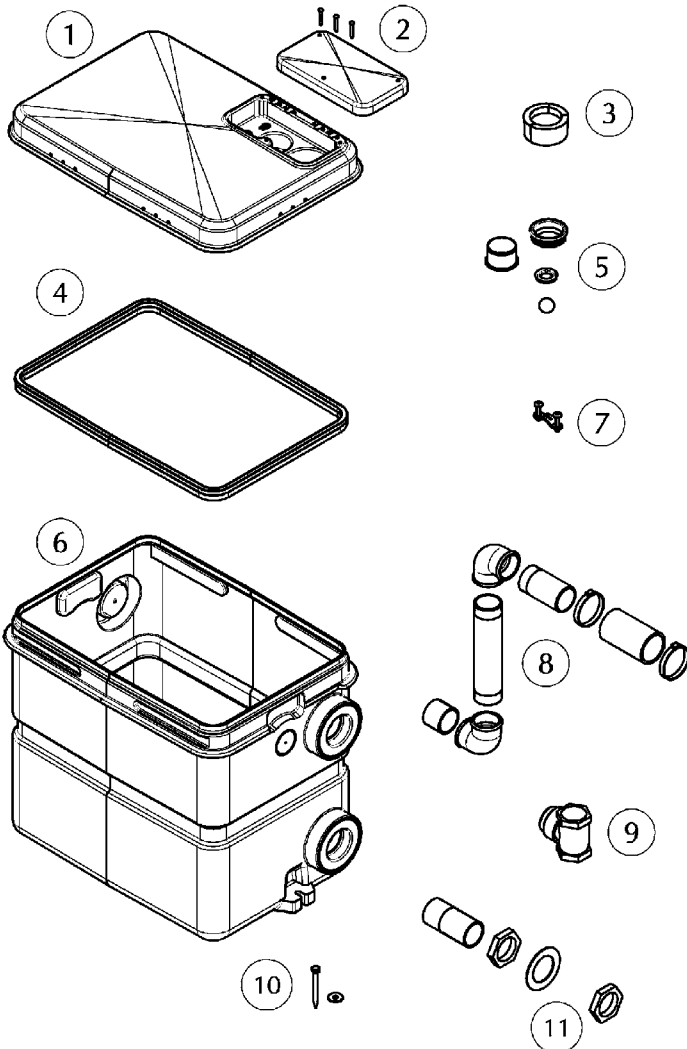

①	Deckel	Cover	JP47557
②	Abdeckung	Cap	JP47547
③	Verschlussstopfen	Sealing plug	JP47550
④	Deckeldichtung	Cover seal	JP47546
⑤	Lüftung	Ventilation	JP47548
⑥	Behälter	Tank	JP47556
⑦	Befestigungsschelle	Mounting clamp	JP47549
⑧	Anschluss-Set	Connecting kit	JP47558
⑨	Rückschlagklappe	Reflux valve	JP47560
⑩	Auftriebssicherung	Buoyancy control	JP47555
⑪	Wanddurchführung	Wall duct	JP47559



**PUMP TECHNICAL
SERVICES LIMITED**

