

HEBEFIX EXTRA

DRAINAGE LIFTING STATION

- Ready to connect
- Quiet
- Integrated ventilation for reliable pump operation
- Flushing device prevents built-up of deposits in the tank
- Runtime monitoring with acoustic alarm and potential-free alarm contact
- Easy to maintain
- High-quality plastic tank (ABS)
- For saline solutions up to 10% salinity



DESCRIPTION

The Hebefix extra lifting station is an easily installed appliance designed for the disposal of aggressive wastewater. The numerous connection options allow the appliance to be connected directly to a water softening plant or gas condensing boiler in order to dispose of the aggressive waste water produced in such systems.

The grey water is pumped to the nearest downpipe through a small-dimensioned pressure pipe (left or right side).

For acoustic failure message, the Hebefix plus contains a runtime monitoring with alarm and a potential-free alarm contact.

The unit is supplied with a submersible pump mounted (U3K extra) which is ready to be plugged to a safety socket and operates fully automatically as soon as wastewater starts to flow in. When installed in bathrooms and shower rooms, the corresponding German VDE regulations must be observed.

The unit is in conformity with the specifications of the EN 12050 standard.

PERFORMANCE

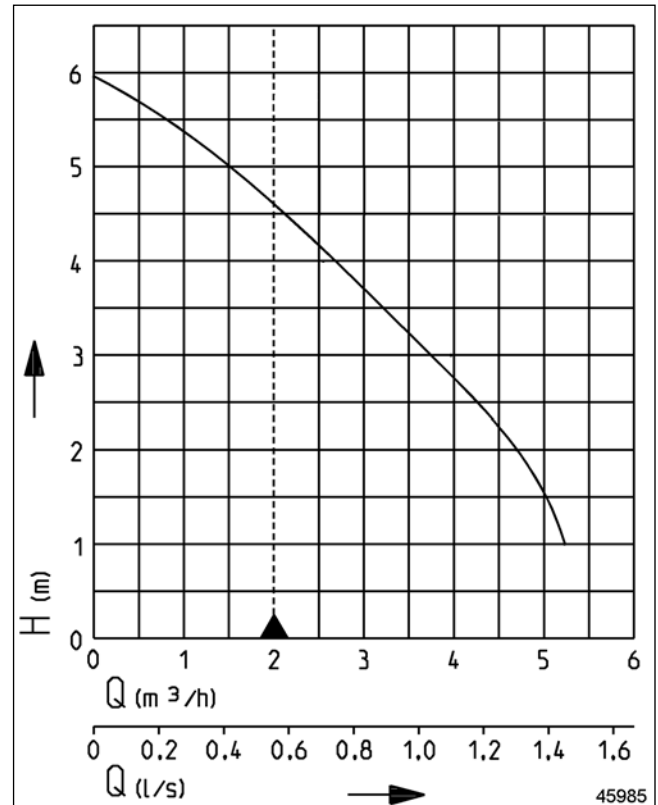

Type	Delivery head H [m]	1	2	3	4	5
Hebefix extra	Flow rate Q [m³/h]	5.0	4.5	3.5	2.5	1.5

We reserve the right to change specifications without notice. Pump performance is subject to ISO 9906 tolerances

The minimum flow velocity in the pressure piping must be 0.7 m/s according to EN 12056. This data is represented in the performance curve as a limit of application.



HEBEFIX EXTRA

DRAINAGE LIFTING STATION

SCOPE OF SUPPLY

Unit including pump, according to EN 12050, ready to connect with cable and plug, complete with collars, outlet elbow,

swing-type check valve 1/4", transition nipple, activated carbon filter, clamps and fastening materials.

MECHANICAL DATA

Pump	Vertical single-stage	Impeller	Vortex impeller, plastic
Free passage	10 mm	Motor housing	Stainless steel
Bearing	Ball bearings, grease-lubricated	Pump housing	Plastic
Seal on motor side	Rotary shaft seal	Submersible	Yes
Oil chamber	Yes	Pressure outlet	DN 32
Seal on medium side	SiC mechanical seal	Tank capacity	19 l
Shaft	Stainless steel	Weight	7 kg

ELECTRICAL DATA

Voltage	1/N/PE~230 V	Type of enclosure	IP 68
Motor rating P1	0.3 kW	Insulation class	B
Motor rating P2	0.2 kW	Winding thermostat	Yes
Current	1.2 A	Motor protection	Installed in the winding
Power line	1,5m H07RN-F	Plug	Safety
Wires	4G0,75		

HEBEFIX EXTRA

Type	Code No.
Hebefix extra UK Plug	JP48429

Dimensions Hebefix extra (mm)

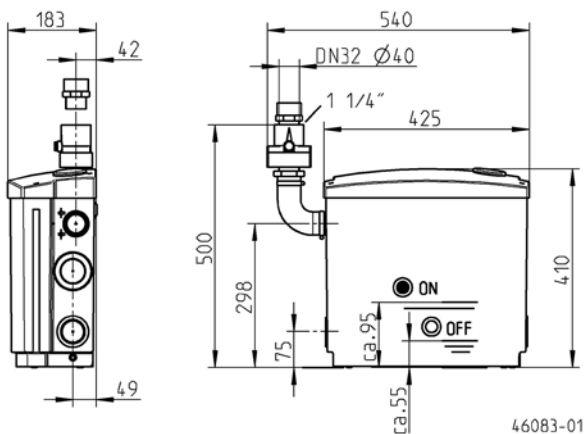

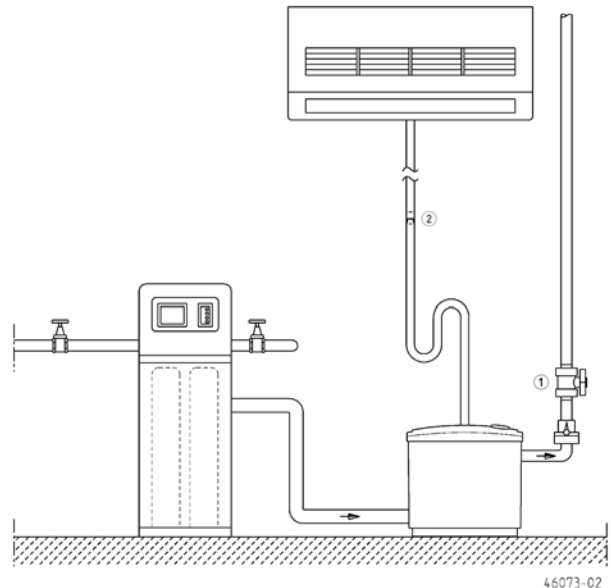

Example of installation



HEBEFIX EXTRA

DRAINAGE LIFTING STATION

MECHANICAL ACCESSORY

			Code No.
	① Stop valve Ball valve	1/4", PVC, for aggressive media 105x155 (HxB)	JP46111
	② Special ventilation	special filter with housing, not for hot water	JP27484

HEBEFIX EXTRA

DRAINAGE LIFTING STATION