



K2 PLUS

EN Instruction Manual

You have purchased a product made by Pentair Jung Pumpen and with it, therefore, also excellent quality and service. Secure this service by carrying out the installation works in accordance with the instructions, so that our product can perform its task to your complete satisfaction. Please remember that damage caused by incorrect installation or handling will adversely affect the guarantee. Therefore please adhere to the instructions in this manual!

This appliance can be used by children aged 8 years or over and by persons with limited physical, sensory or intellectual capabilities, or with limited experience and knowledge, provided that they are supervised or have been instructed in the safe use of the appliance and are aware of the dangers involved. Children must not be allowed to play with the appliance. Cleaning and user maintenance must not be carried out by children unless they are supervised.

Damage prevention in case of failure

Like any other electrical device, this product may fail due to a lack of mains voltage or a technical defect.

If damage (including consequential damage) can occur as a result of product failure, the following precautions can be taken at your discretion:

- Installation of a water level dependent (under circumstances, mains-independent) alarm system, so that the alarm can be heard before damage occurs.
- Inspection of the collecting tank/chamber for tightness up to the top edge before – or at the latest, during – installation or operation of the product.
- Installation of backflow protection for drainage units that can be damaged by wastewater leakage upon product failure.
- Installation of a further product that can compensate in case of failure of the other product (e.g. duplex unit).
- Installation of an emergency power generator.

As these precautions serve to prevent or minimise consequential damage upon product failure, they are to be strictly observed as the manufacturer's guideline – in line with the standard DIN EN specifications as state of the art – when using the product (Higher Regional Court Frankfurt/Main, Ref.: 2 U 205/11, 06/15/2012).

SAFETY INSTRUCTIONS

This instruction manual contains essential information that must be observed during installation, operation and servicing. It is therefore important that the installer and the responsible technician/operator read this instruction manual before the equipment is installed and put into operation. The manual must always be available at the location where the pump or the plant is installed.

Failure to observe the safety instructions can lead to the loss of all indemnity.

In this instruction manual, safety information is distinctly labelled with particular symbols. Disregarding this information can be dangerous.



General danger to people



Warning of electrical voltage

NOTICE! Danger to equipment and operation

Qualification and training of personnel

All personnel involved with the operation, servicing, inspection and installation of the equipment must be suitably qualified for this work and must have studied the instruction manual in depth to ensure that they are sufficiently conversant with its contents. The supervision, competence and areas of responsibility of the personnel must be precisely regulated by the operator. If the personnel do not have the necessary skills, they must be instructed and trained accordingly.

Safety-conscious working

The safety instructions in this instruction manual, the existing national regulations regarding accident prevention, and any internal working, operating and safety regulations must be adhered to.

Safety instructions for the operator/user

All legal regulations, local directives and safety regulations must be adhered to.

The possibility of danger due to electrical energy must be prevented.

Leakages of dangerous (e.g. explosive, toxic, hot) substances must be discharged such that no danger to people or the environment occurs. Legal regulations must be observed.

Safety instructions for installation, inspection and maintenance works

As a basic principle, works may only be carried out to the equipment when it is shut down. Pumps or plant that convey harmful substances must be decontaminated.

All safety and protection components must be re-fitted and/or made operational immediately after the works have been completed. Their effectiveness must be checked before restarting, taking into account the current regulations and stipulations.

Unauthorised modifications, manufacture of spare parts

The equipment may only be modified or altered in agreement with the manufacturer. The use of original spare parts and accessories approved by the manufacturer is important for safety reasons. The use of other parts can result in liability for consequential damage being rescinded.

Unauthorised operating methods

The operational safety of the supplied equipment is only guaranteed if the equipment is used for its intended purpose. The limiting values given in the "Technical Data" section may not be exceeded under any circumstances.

Instructions regarding accident prevention

Before commencing servicing or maintenance works, cordon off the working area and check that the lifting gear is in perfect condition.

Never work alone. Always wear a hard hat, safety glasses and safety shoes and, if necessary, a suitable safety belt.

Before carrying out welding works or using electrical devices, check to ensure there is no danger of explosion.

People working in wastewater systems must be vaccinated against the pathogens that may be found there. For the sake of your health, be sure to pay meticulous Notice to cleanliness wherever you are working.

Make sure that there are no toxic gases in the working area.

Observe the health and safety at work regulations and make

sure that a first-aid kit is to hand.

In some cases, the pump and the pumping medium may be hot and could cause burns.

For installations in areas subject to explosion hazards, special regulations apply!

USE

The K2 plus condensate pump was specially developed for removing aggressive condensate from condensing boilers (up to 100 kW), refrigerated and freezer display cases, air conditioning systems and air dehumidifiers.

NOTICE! The maximum admissible temperature of the pumped media is 40°C. In the event of higher media inlet temperatures, even for a short time, the inlet hose must be laid in the form of several cooling loops.

Provided that regular maintenance is performed, the pump unit can convey condensate with a pH value of ≥ 2.7 . If lower pH values are present, even if only intermittently, then a neutralisation system must be fitted upstream.

In addition, local conditions or particular technical or legal requirements (such as local drainage bye-laws) may require the use of a neutralisation system.

NOTICE! Admixtures of oils, particularly essential oils, are not permitted.

The use of the K2 plus is not permissible for removing waste water, such as from washbasins.

CAUTION!

Condensates from condensing boilers contain acids! These can cause irreparable damage if they come into contact with skin or eyes.

NOTICE! The maximum influx is 14 l/h. The temporary peak influx, such as when defrosting must not exceed 70 l/h.

NOTICE! The maximum delivery head of 3.5 metres must not be exceeded in order to prevent deposits from forming and keep the pump in good working order.

It is not permitted to use the K2 plus outdoors. When installed in bath and shower rooms, the applicable electrical regulations must be observed (in Germany VDE 0100 part 701)! You will find further information in the DWA working paper "Condensates from condensing boilers" (ATV-DVWL-A 251).

If installed in compliance with the regulations and used properly, then this pump unit meets the protective requirements of the EMC Directive 2014/30 EU and is suitable for domestic use and connection to a power supply from the grid.

Storage

The K2 plus is frost-free if stored in a dry place at up to -20°C. The condensate in the system must not freeze however in its built-in state.

ELECTRICAL CONNECTION

Current applicable standards (such as EN standards), national regulations (such as VDE in Germany), and the regulations of the local power supply companies must be complied with.

NOTICE! Only qualified electricians may carry out electrical work on the pump, plug or the control unit.

NOTICE! Never put the mains plug in water! If water gets into the plug, this can cause malfunctions and damage.

Observe the operating voltage (see type plate)!

WARNING!

Only connect the pump to electrical circuits that have been installed properly in accordance with the regulations and are fitted with at least a 10 A (delay) fuse and an FI circuit breaker (≤ 30 mA).

No additional motor protection is required, since the system has an integrated winding thermostat.

Unacceptably high temperatures cause the thermostat to shut down the motor.

WARNING!

After the thermostat has switched the system off, unplug the mains cable before remedying the fault, since the pump unit can switch itself on again automatically if the power is still connected!

Level control

The pump is switched on and off automatically depending on the level of water in the collecting tank. A multi-coloured display in the lid indicates the current operating status of the unit:

- Green - Standby
- Green flashing - Pump in operation
- Green/orange - Alarm, pump is running
- Red - Alarm, pump switched off

Alarm

① The first alert level is for early reporting of faults (such as kinked piping, inadequate pump performance) before more serious failure can occur.

If the condensate pump runs but does not reach the switch-off point within approximately 60 seconds, then the alarm will sound. A loud alarm tone sounds, the display on the top flashes green/orange, the potential-free contact is switched, but the pumps carries on running.

If the K2 plus reaches the switch-off point within the 60 seconds that follow, it will revert to "standby" mode and the alarm will stop.

② If the switch-off level is not reached within a total of 120 seconds, then the condensate pump will shut down for safety reasons to prevent damage from occurring as a result.

The alarm continues to sound as a continuous tone, the display in the lid will light up red, and the potential-free fault indicator contact will remain activated.

To turn off the continuous alarm tone, briefly interrupt the power supply (unplug it from the mains, remove the fuse, ...).

Remote alarm indication

The standard fault indicator contact (change-over contact 0.5A/230V) is designed for connecting an external alarm device or for the fault indicator input of the heating control system). When resting, contacts 40/42 are closed, and if the alarm sounds in a continuous tone then contacts 40/41 are closed.

For the alarm relay system, a multi-conductor sheathed cable with a rated voltage of at least 300/500 V must be used, such as H05... or equivalent; permissible wire size 0.5 - 1.5 mm². To ensure that the strain relief and seal function properly, the cable must have a diameter between 5 and 8 mm.

The length of the free conductors (unsheathed length) should be kept as short as possible (not longer than 15 mm).

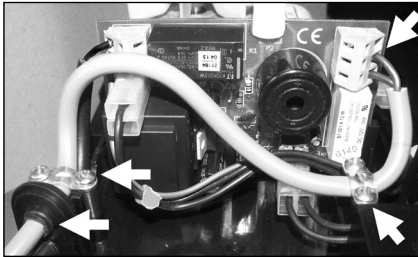

Insert the alarm connection cable into the condensate pump housing parallel to the mains cable. To do so, the second opening in the cable grommet must be opened up.

Feed the cable through the two strain relief clamps to terminals 40-41-42. When connecting the conductors, make sure that they are securely fixed to the terminals. Then tighten both clamps.

INSTALLATION

NOTICE! It is not permitted to use the appliance outdoors.

The following points must be observed when choosing a suitable location for installing the pump:

- The condensate must flow into the condensate pump from the siphon trap using gravity.
- The louvres on the K2 plus for ventilating the pump must not be obstructed.
- The connecting hoses must be laid in such a way that there are no kinks in the piping.
- The K2 plus must be easy to access to allow maintenance to be carried out.

Pump

The condensate pump can be either floor-standing or wall-mounted.

If wall-mounted, the distance between drill-holes must be 19.5 cm. Please use the fastening hardware supplied. It is easy to level off the pump using the grid pattern on the back of the pump.

NOTICE! The pump must be installed in an absolutely horizontal position as shown in the example.

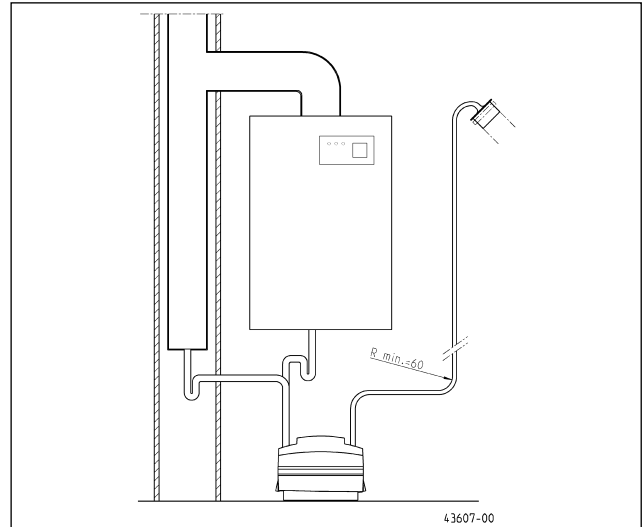

Inlet

The K2 plus has three inlets from above (2x $\varnothing 28$ and 1x $\varnothing 33$). Unused openings must be closed off with plugs. The inlet hose from the boiler or refrigerator/air conditioning must be laid in such a way that the condensate can flow into the pump from the siphon trap using gravity. To avoid obstructions, the inlet hose must be cut off obliquely. A siphon must be fitted in all inlets, unless this is already available in the heater, to prevent exhaust from entering.

The connection of safety modules is not permissible.

Pressure line

NOTICE! Do not use grease or hose clamps to attach the hose to the discharge branch.

The hose must be laid from the condensate pump to the wastewater collecting sewer. The DN 50 connection piece supplied facilitates the connection. The smallest admissible radius when laying the hose is 60 mm.

It would be advantageous if the hose outlet was located at approximately the same height as the pump. This would considerably enhance the pumping performance, avoid deposits in the hose and extend the life of the pump as a result.

Take the pressure line up vertically to the highest possible point and then route it to the discharge point with a slight downward gradient.

NOTICE! The pressure line, from its highest point, must be able to completely discharge its contents. Pockets of air in the pressure line increase the pumping resistance.

Alternatively to using the hose supplied ($\varnothing 10$ mm), it is also possible to use your own 12 mm hose for this purpose. This will reduce the resistance and increase the pump performance if necessary.

NOTICE! If the condensate pump is installed below the back-flow level and the discharge point is located on a sewer which is below the back-flow level and is not protected against back-flow, then the pressure line must be laid with a loop located above the back-flow level. The connection to the sewer must be pressure-tight.

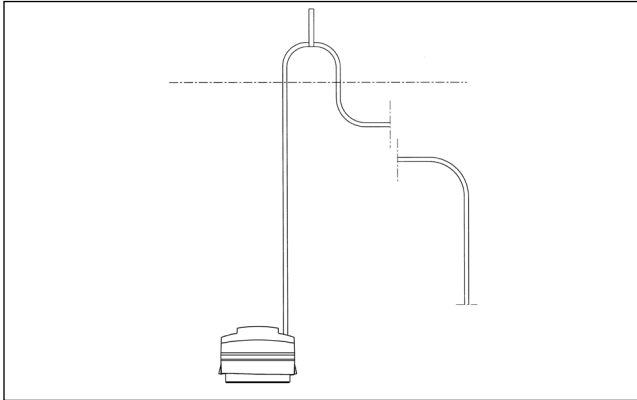

Emergency overflow

To prevent damage to property, the emergency overflow can be used in conjunction with the alarm contact.

The emergency overflow is used for systematically draining off condensates in the event of a pump breakdown.

NOTICE! It must be ensured that the condensate can drain off into an emergency tank by gravity and the hose is completely emptied.

At the same time, the alarm contact in the pump can be used to turn off the heater or air-conditioner to prevent further condensate from occurring in the event of a fault.

MAINTENANCE



WARNING!

Before carrying out any works: disconnect the pump and the controls from the mains and take steps to ensure that it cannot be energized again.



WARNING!

Check the mains cable for signs of mechanical and chemical damage. Damaged or kinked cables must be replaced.



CAUTION!

Condensates from condensing boilers contain acids! These can cause irreparable damage if they come into contact with skin or eyes.

In view of the different uses, various types of contamination can occur: Limescale, algae growth and dust from air conditioning/refrigeration or crusts due to acids from condensing boilers.

This contamination must be removed regularly to ensure proper operation and maximum pump efficiency.

1. The upper section of the pump does not need to be opened for cleaning or maintenance purposes. Disengage the condensate collector by rotating the two side fasteners by a 1/4 turn (->open). Put your forefingers under the two side fasteners, and your thumbs in the side pockets and then lift the upper section off with your forefingers. In wall-mounted appliances, press the condensate collector downwards while the upper section remains on the wall.

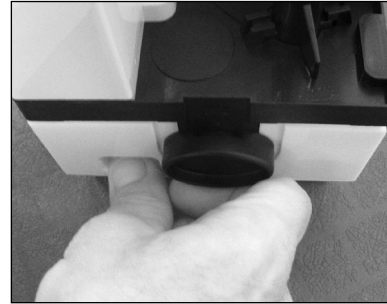

2. Clean the float switch and the condensate collector.
3. Before assembling these parts again, please grease the sealing ring with a sanitary fitting lubricant, e.g. high-temperature grease.
4. Check the back-flow prevention valve to ensure it does not leak, and clean it if necessary. To do so, open the bayonet joint on the discharge branch and take the valve out. If condensate now leaks, empty the hose, clean the rubber seal and ball and replace if necessary. Assemble the parts again and connect the pressure line with the bayonet joint.
5. After completing these steps, conduct a performance test with the test run button (rear left). The alarm can also be tested by pressing the test run button for more than 60 seconds and for more than 120 seconds.

QUICK TIPS FOR REMEDYING FAULTS

Pump does not work

- Press the test run button. If the pump is now running, check the float switch and clean it if necessary.
- Check the mains voltage, the fuse and the FI circuit breaker. Replace defective fuses only with fuses with the same nominal value. If the fuse triggers again, call our service engineers.
- If the mains cable is damaged, it must be replaced by the manufacturer only.

Decreased pumping performance

- Pressure line, pump or back-flow prevention valve obstructed = clean. **Notice!** If possible, reduce the length of the hose or install the end of the pressure line at a lower level. This will increase the rate of flow in the hose and avoid deposits.
- Provide and use a hose with a larger internal diameter (12 mm)
- The pressure line is kinked or flattened = observe minimum installation radius of 60 mm when laying it.
- Rotor worn out = have it replaced by the manufacturer since special tools are required for this

Back-flow prevention valve is leaking

- Valve is contaminated = clean it or replace it

Short alarm tone during pumping operation

- Please refer to "Decreased pumping performance"
- Influx too large

Continuous alarm tone if tank is full

- Please refer to "Decreased pumping performance"
- Motor obstructed or faulty

NOTE! To turn off the continuous alarm tone, briefly interrupt the power supply (unplug it from the mains, remove the fuse, ...).

Technische Daten - Technical Data - Caractéristiques techniques - Technische Gegevens - Dati Tecnici - Dane techniczne - Műszaki adatok - 技术数据

	3,1	[kg]
P1	65	[W]
U	1/N/PE ~230	[V]
f	50	[Hz]
IP	44	
L _p	70	[dB(A)]

Leistung - Performance - Capaciteit - Prestazioni - Wydajności i moce - Teljesítmény - 性能

H [m]	1,5	2,0	2,5	3,0	3,5
Q [l/h]	520	440	365	290	200

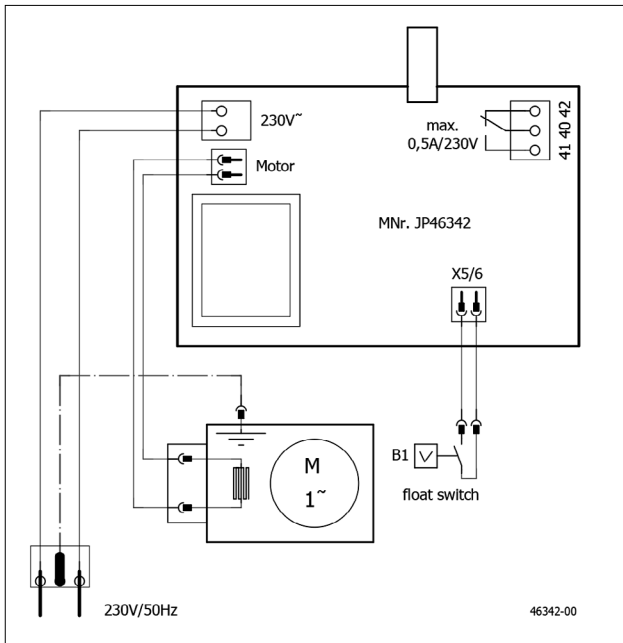
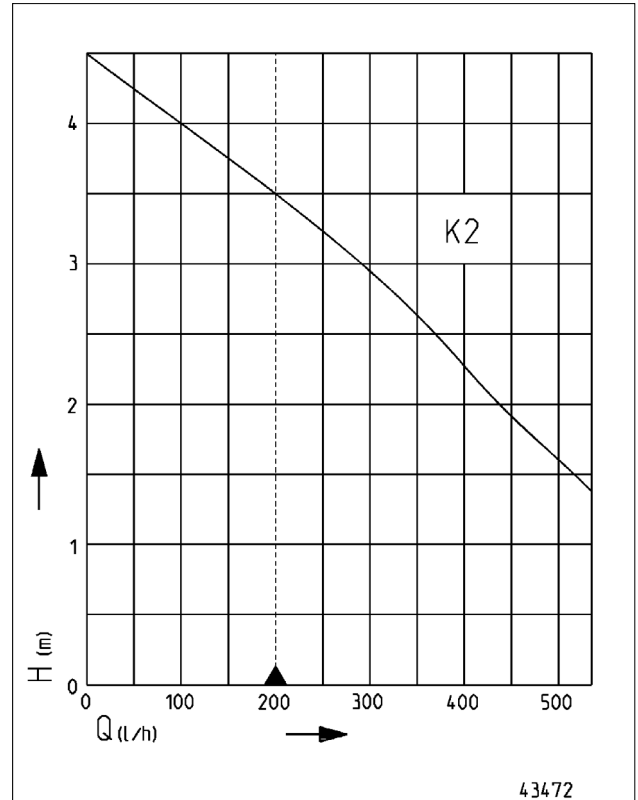
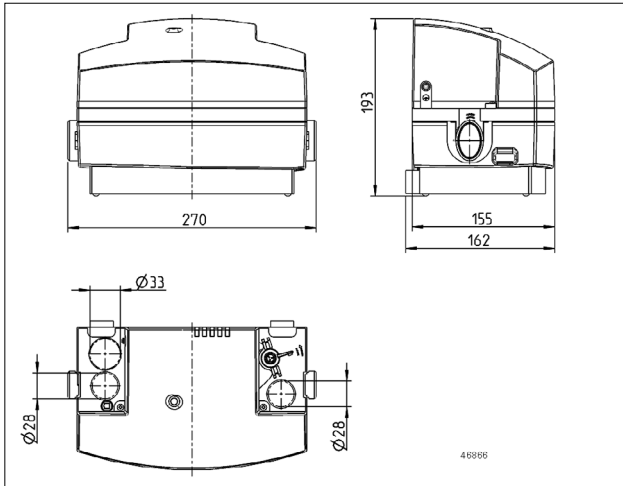

Max. Pumpenlaufzeit: siehe Abschnitt "Alarm".

The maximum running time of the pump is described in the section entitled "Alarm".

Durée de fonctionnement max. de la pompe : voir paragraphe « Alarme ».

Max. pomplooptijd: zie hoofdstuk "Alarm".

Per il tempo massimo di funzionamento della pompa vedere il paragrafo "Allarme".

Maksymalny czas biegu pompy: patrz rozdział „Alarm”.

A szivattyú maximális menetidejéről lásd a „Riasztás” c. részt.

关于泵的最大运行时间, 请参考“警报”章节。

EU-Konformitätserklärung
EU-Prohlášení o shodě
EU-Overensstemmelseserklæring
EU-Declaration of Conformity
EU-Vaatumustenmukaisuusvakuutus

EU-Déclaration de Conformité
EU-Megfelelőségi nyilatkozat
EU-Dichiarazione di conformità
EU-Conformiteitsverklaring
EU-Deklaracja zgodności

EU-Declarație de conformitate
EU-Vyhlášení o zhode
EU-Försäkran om överensstämmelse

DE - Richtlinien - Harmonisierte Normen
CS - Směrnice - Harmonizované normy
DA - Direktiv - Harmoniseret standard
EN - Directives - Harmonised standards
FI - Direktiivi - Yhdenmukaistettu standardi

FR - Directives - Normes harmonisées
HU - Irányelve - Harmonizált szabványok
IT - Direttive - Norme armonizzate
NL - Richtlijnen - Geharmoniseerde normen
PL - Dyrektywy - Normy zharmonizowane

RO - Directivă - Norme coroborate
SK - Smernice - Harmonizované normy
SV - Direktiv - Harmoniserade normer

• **2006/42/EG (MD)**
• **2011/65/EU (RoHS)**
• **2014/30/EU (EMC)**

EN 60335-1:2012/A11:2014

EN 55014-1:2006/A2:2011, EN 55014-2:1997/A2:2008, EN 61000-3-2:2014, EN 61000-3-3:2013

JUNG PUMPEN GmbH - Industriestr. 4-6 - 33803 Steinhagen - Germany - www.jung-pumpen.de

DE - Wir erklären in alleiniger Verantwortung, dass das Produkt den aufgeführten Richtlinien entspricht.
CS - Prohlašujeme na svou výlučnou odpovědnost, že výrobek odpovídá jmenovaným směrnicím.
DA - Vi erklærer under ansvar at produktet i overensstemmelse med de retningslinjer
EN - We hereby declare, under our sole responsibility, that the product is in accordance with the specified Directives.
FI - Me vakuutamme omalla vastuullamme, että tuote täyttää ohjeita.
FR - Nous déclarons sous notre propre responsabilité que le produit répond aux directives.
HU - Kizárólagos felelősségünk tudatában kijelentjük, hogy ez a termék megfelel az Európai Unió fentnevezett irányelveinek.
IT - Noi dichiariamo sotto la nostra esclusiva responsabilità che il prodotto è conforme alle direttive citate
NL - Wij verklaren geheel onder eigen verantwoordelijkheid dat het product voldoet aan de gestelde richtlijnen.
PL - Z pełną odpowiedzialnością oświadczamy, że produkt odpowiada postanowieniom wymienionych dyrektyw.
RO - Declaram pe proprie răspundere că produsul corespunde normelor prevăzute de directivele mai sus menționate.
SK - Na výlučnú zodpovednosť vyhlasujeme, že výrobok spĺňa požiadavky uvedených smerníc.
SV - Vi försäkrar att produkten på vårt ansvar är utförd enligt gällande riktlinjer.

K2 plus (JP46589)

DE - Weitere normative Dokumente CS - Jinými normativními dokumenty DA - Andre normative dokumenter EN - Other normative documents FI - Muiden normien FR - Autres documents normatifs HU - Egyéb szabályozó dokumentumokban leírtaknak IT - Altri documenti normativi NL - Verdere normatieve documenten PL - Innymi dokumentami normatywnymi RO - Alte acte normative SK - Iným záväzným dokumentom SV - Vidare normerande dokument:

DE - Bevollmächtigter für technische Dokumentation CS - Oprávněná osoba pro technickou dokumentaci DA - Autoriseret person for teknisk dokumentation EN - Authorized person for technical documentation FI - Valtuutettu henkilö tekninen dokumentaatio FR - Personne autorisée à la documentation technique HU - Hivatalos személyi műszaki dokumentáció IT - Persona abilitata per la documentazione tecnica NL - Bevoegd persoon voor technische documentatie PL - Pełnomocnik ds. dokumentacji technicznej RO - Persoană autorizată pentru documentație tehnică SK - Oprávněná osoba pre technickú dokumentáciu SV - Auktoriserad person för teknisk dokumentation:

JUNG PUMPEN - Stefan Sirges - Industriestr. 4-6 - 33803 Steinhagen

Steinhagen, 20-09-2018

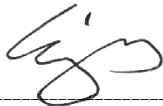

Stefan Sirges, General Manager

i.V. Rüdiger Rokohl, Sales Manager

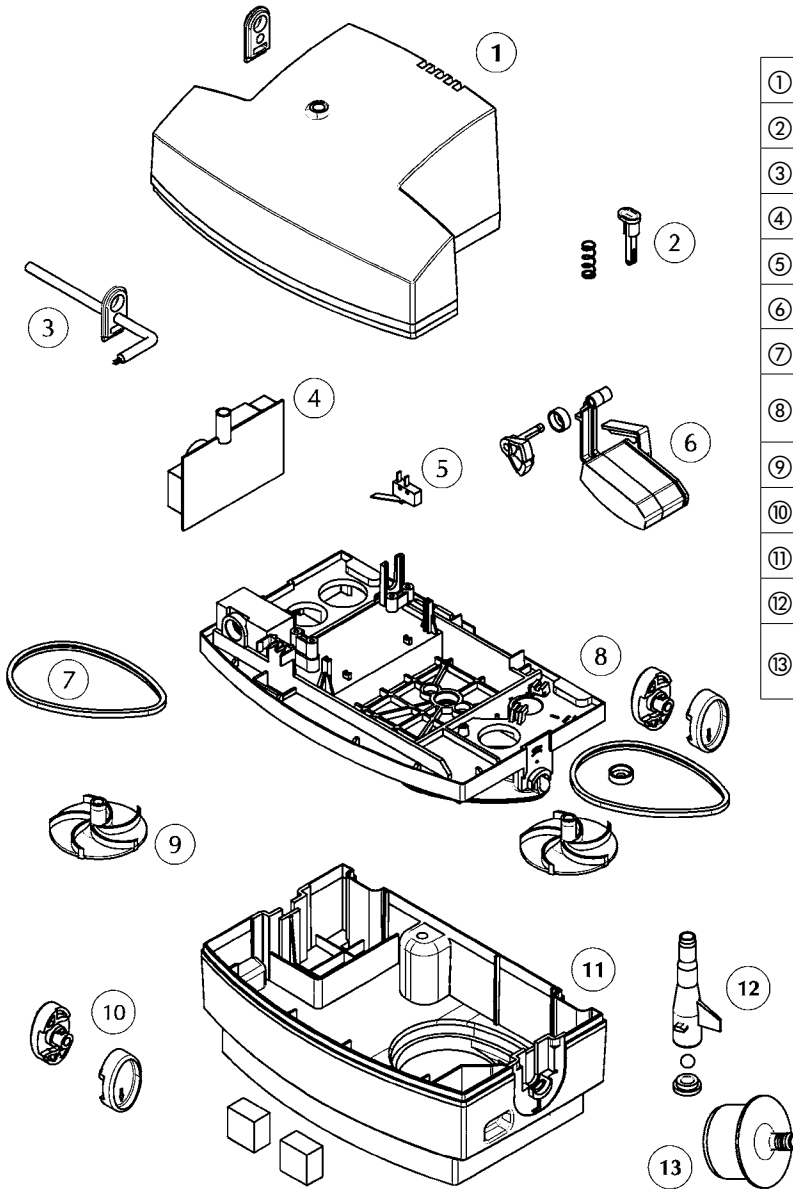

K2 PLUS (JP46589)

Spare Parts



①	Haube	Hood	JP47008
②	Probelauftaster	Push button trial run	JP47000
③	Netzleitung	Cable	JP47006
④	Steuerung	Control panel	JP47002
⑤	Schalter	Switch	JP47001
⑥	Schwimmer	Float	JP46999
⑦	Lippendichtung	Lip seal ring	JP47004
⑧	Komponenten-träger	Component receiver	JP47009
⑨	Lauftrad	Impeller	JP47005
⑩	Verschlüsse	Locking device	JP47010
⑪	Kondensatwanne	Condensate tank	JP47007
⑫	Rückschlagventil	Non-return valve	JP47003
⑬	Anschluss-Set DN50	Connection-Set DN 50	JP41200



**PUMP TECHNICAL
SERVICES LIMITED**

