

# MULTICUT TANDEM

## SEWAGE PUMPS

- Cutting rotor with stirring effect
- Plug-in cable connection
- External adjustable cutting mechanism
- Controllable oil chamber
- SiC mechanical seal independent of sense of rotation
- Moisture-sealed cable inlet
- Installed motor protection



### DESCRIPTION

Centrifugal submersible sewage pumps fitted with the MultiCut cutting system are used as stationary appliances in pressurised drainage systems for discharge in sparsely populated areas or of detached houses. They are suitable for pumping domestic wastewater with the usual additions (as specified in German standard DIN 1986, Part 3).

In the MultiCut tandem systems (TAN), two MultiCut pumps are connected to one unit in order to achieve a higher head.

For pumping from ducts which are connected to the public sewer system, explosion-proof submersible pumps of the UFK series have to be used. On account of the upstream cutting system, the pressurised line as from DN 32 - as from DN 80 minimum without cutting system - may be routed parallel to the terrain.

Operating conditions up to a temperature of the material to be transported of 40° Celsius

Submerged motor:

Continuous operation (S1)

Emerged motor:

Intermittent operation (S3)(e.g. 40% = 4 min. operation, 6 min. break)

The unique MultiCut cutting system ensures a maximum of operational safety at outstanding delivery characteristics. Fitted with a cutter plate made of hardened stainless steel and a three-bladed knife, it disintegrates coarse additions in the wastewater with more than 62,000 cutting processes per minute before they can get into the pump hydraulics. Solids which cannot be transported are rejected outside of the pump by the cutting rotor as the cutting system is located upstream from the pump hydraulics. Specifically arranged grooves on the cutter plate ensure additional safety as the cutting unit is permanently cleaned automatically during the delivery.

### PERFORMANCE

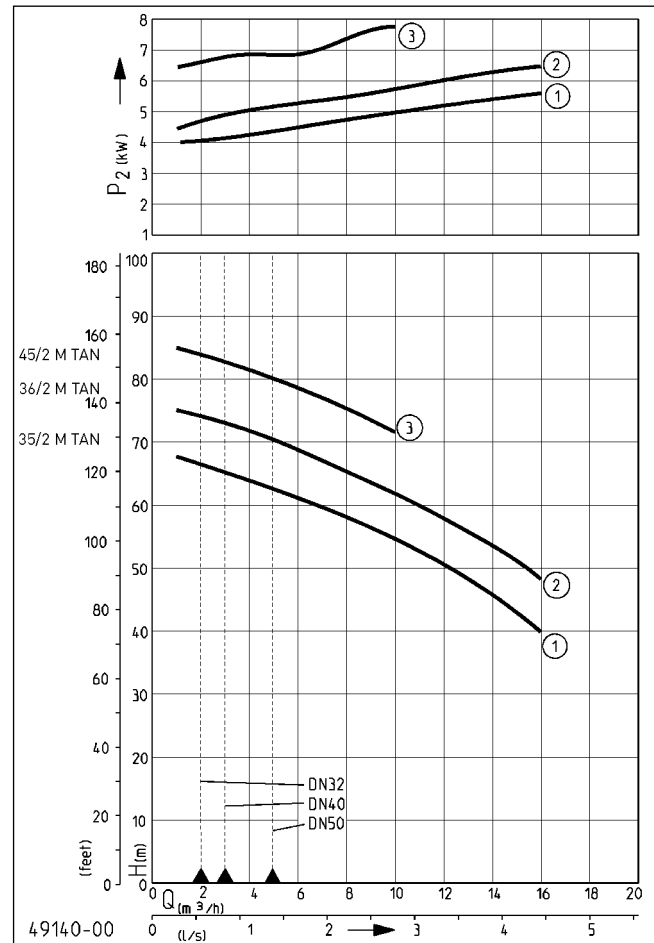

Type	Delivery head H [m]	40	44	48	52	56	60	64	68	72	76	80	84
35/2 M Tan	Flow rate Q [m³/h]	16.0	15.0	13.5	11.5	9.5	7.0	4.0	1.0				
36/2 M Tan				16.0	15.0	13.0	11.0	9.0	6.5	3.5			
45/2 M Tan										10.0	8.0	5.0	2.0

We reserve the right to change specifications without notice. Pump performance is subject to ISO 9906 tolerances

The minimum flow velocity in the pressure piping must be 0.7 m/s according to EN 12056. This data is represented in the performance curve as a limit of application.



# MULTICUT TANDEM

## SEWAGE PUMPS

### SCOPE OF SUPPLY

Sewage pumps with ex-proof in keeping with German/European standard EN 12050, 10 m cable, without plug.

Attention: Further mechanical and electrical accessory on request. All electrical data refer to a single pump!

Ex II 2 G Ex d IIB T4

### MECHANICAL DATA

Pump	vertical, double-stage	Run dry protection	Yes
Ex-proof	With ex-proof	Impeller	Vortex impeller, grey cast iron
Bearing	Ball bearings, grease-lubricated	Motor housing	Grey cast iron
Seal on motor side	Duplex rotary shaft seals	Pump housing	Grey cast iron
Oil chamber	Yes	Submersible	Yes
Seal on medium side	SiC mechanical seal	Pressure outlet	DN 32

### ELECTRICAL DATA

Voltage	3/PE~400 V	Insulation class	F
Power line	10m H07RN-F	Winding thermostat	Yes
Wires	6G1,5	Motor protection	Thermostat
Type of enclosure	IP 68	Fuse	10 A

### MULTICUT TANDEM

Type	Code No.	Motor rating		Current	S3	Weight
		P1	P2			
35/2 M Tan, EX	<b>JP09179</b>	3.70 kW	3.04 kW	6.6 A	40 %	94 kg
36/2 M Tan, EX	<b>JP09180</b>	4.20 kW	3.42 kW	7.3 A	30 %	94 kg
45/2 M Tan, EX	<b>JP48306</b>	4.84 kW	3.93 kW	7.9 A	25 %	97 kg

# MULTICUT TANDEM

## SEWAGE PUMPS

### Dimensions tandem system (mm)

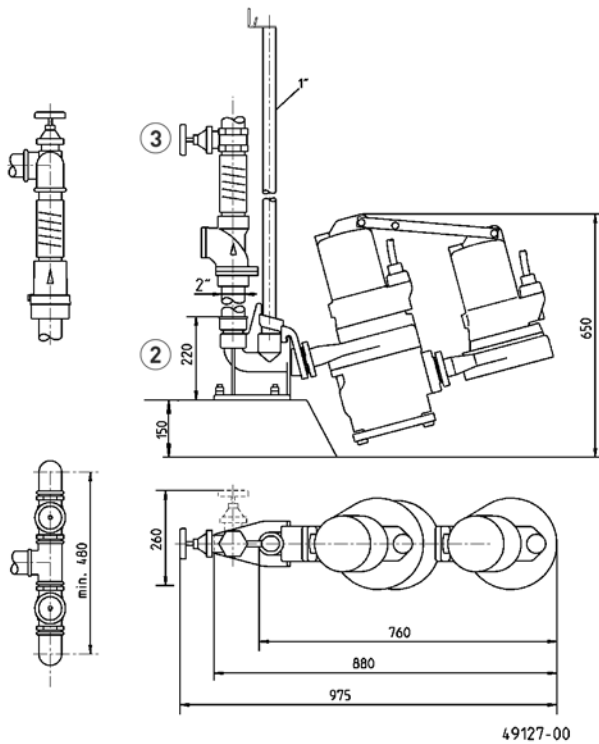

### Example of tandem system installation

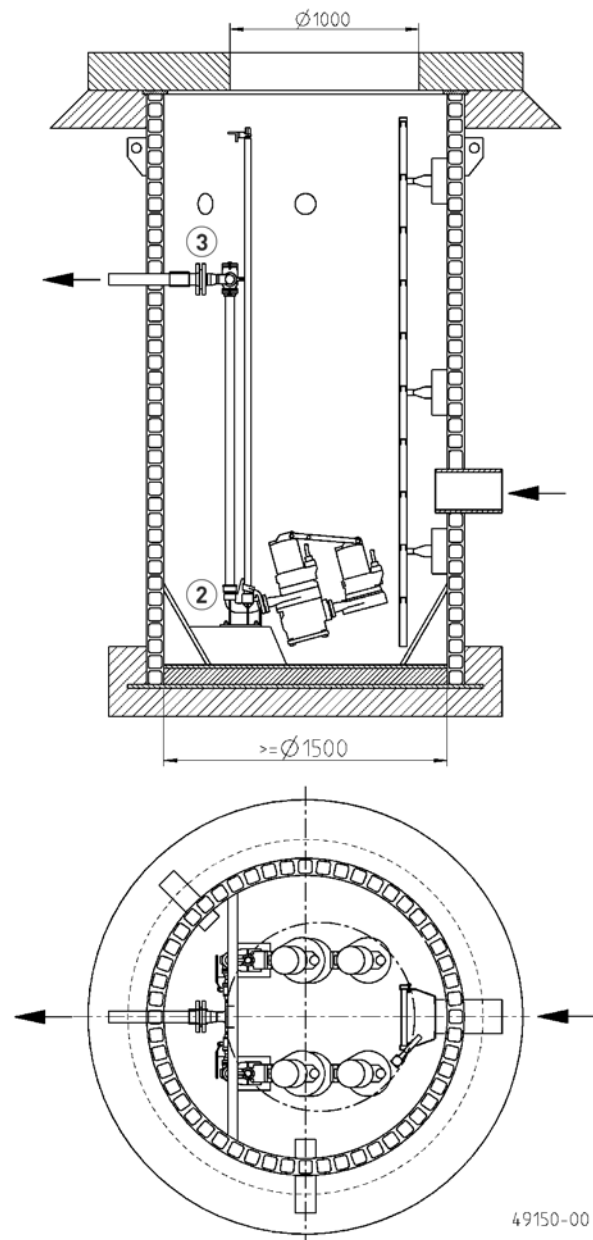

### MECHANICAL ACCESSORY

			Code No.	
	<b>① Chain</b>	certified, 2.5 m, 320 kg, 5 rings (EN 818 mod.)	<b>JP45901</b>	
		certified, 5.0 m, 320 kg, 8 rings (EN 818 mod.)	<b>JP45902</b>	
		certified, 7.5 m, 320 kg, 11 rings (EN 818 mod.)	<b>JP47365</b>	
		Shackle, certified, 630 kg, stainless steel	<b>JP45904</b>	
	<b>② Guide rail system</b>	GR 35	1 1/2" female thread for MultiCut pumps	<b>JP14094</b>
		Guide rail 1"	1500 mm	<b>JP48937</b>
		Guide rail 1"	2000 mm	<b>JP48938</b>
		Guide rail 1"	2500 mm	<b>JP48939</b>
		Guide rail 1"	3000 mm	<b>JP48940</b>

# MULTICUT TANDEM

## SEWAGE PUMPS

### MECHANICAL ACCESSORY

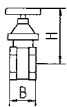
				Code No.
	③ Stop valve	brass, 1½" (DN 40), PN 16	125x60 (HxB)	JP44786
		stainless steel, 1½" (DN 40), PN 16	125x80 (HxB)	JP48403
		brass, 2" (DN 50), PN 16	140x70 (HxB)	JP44787

### ELECTRICAL ACCESSORY

			Code No.
	ⓐ Seal leak detector	DKG Ex for explosion-proof pumps	JP00249