

PLANCOFIX LINE

FLOOR DRAINAGE PUMPS

- Modern bathroom design with line drainage
- Installation depth 9 cm
- Shower channel can be shortened individually
- Very quiet: < 30 dB(A)
- Sealing fleece according DIN 18534:
Leak tightness class W3-I
Tear strength class R3-I
- Easy cleaning/maintenance
- Optional secondary drain



DESCRIPTION

Plancofix is a floor drain pump that enables barrier-free or low entry showers even where the missing gravity drain ruled out this option in the past. Plancofix is a device for dewatering showers and must not be used for backwater protection.

Placed into the screed, the Plancofix replaces the ordinary floor drain in tiled showers. The shower water is being pumped to the nearest gravity pipe through a 1 inch pressure pipe. The hand-over point to the gravity pipe should be 25 cm higher than the Plancofix.

The body of Plancofix line requires an installation depth of 9 cm incl. insulation tray. The shower channel requires a slight gradient to the center.

PERFORMANCE

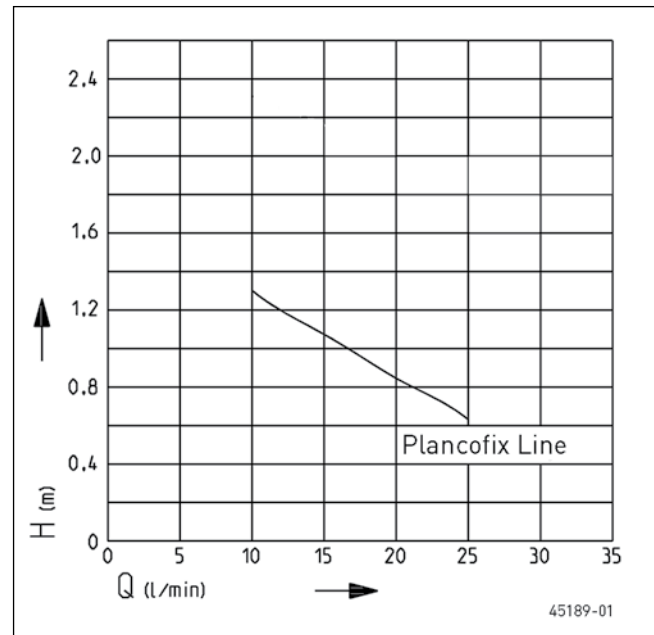

Type	Delivery head H [m]	0.5	1	1.3
Plancofix Line	Flow rate Q [l/min]	26	16	10

We reserve the right to change specifications without notice. Pump performance is subject to ISO 9906 tolerances



PLANCOFIX LINE

FLOOR DRAINAGE PUMPS

SCOPE OF SUPPLY

Ready to connect unit with synchronous motor and non-blocking hydraulic. Built-in swing-type check valve, tileable floor drain, insulating tray for sound compensation, cover and screws in

stainless steel, height adjustment feet and pre-assembled sealing fleece.

MECHANICAL DATA

Pump	Vertical single-stage	Pressure outlet	1" IG
Mounted circuit	Yes	Weight	4.5 kg

ELECTRICAL DATA

Voltage	1/N/PE~230 V	Wires	3G0,75 GR
Motor rating P1	30 W	Winding thermostat	Yes
Current	0.2 A	Motor protection	Installed in the winding
Power line	5m H05VV-F	Plug	Without

PLANCOFIX LINE

Type	Code No.
Plancofix Line	JP50177

Dimensions Plancofix Line (mm)

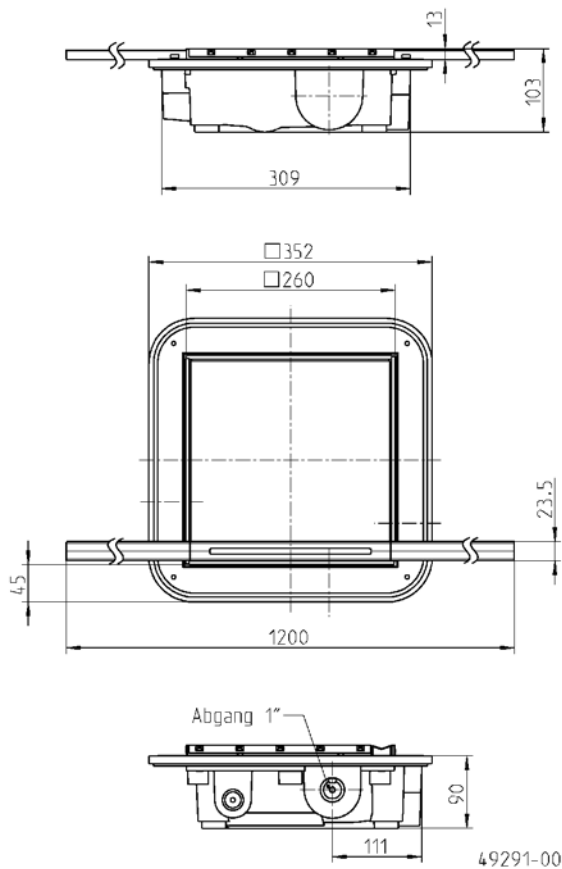

Example of installation Plancofix Line

