



BAUFIX 200

EN Instruction Manual



Baufix 200-32

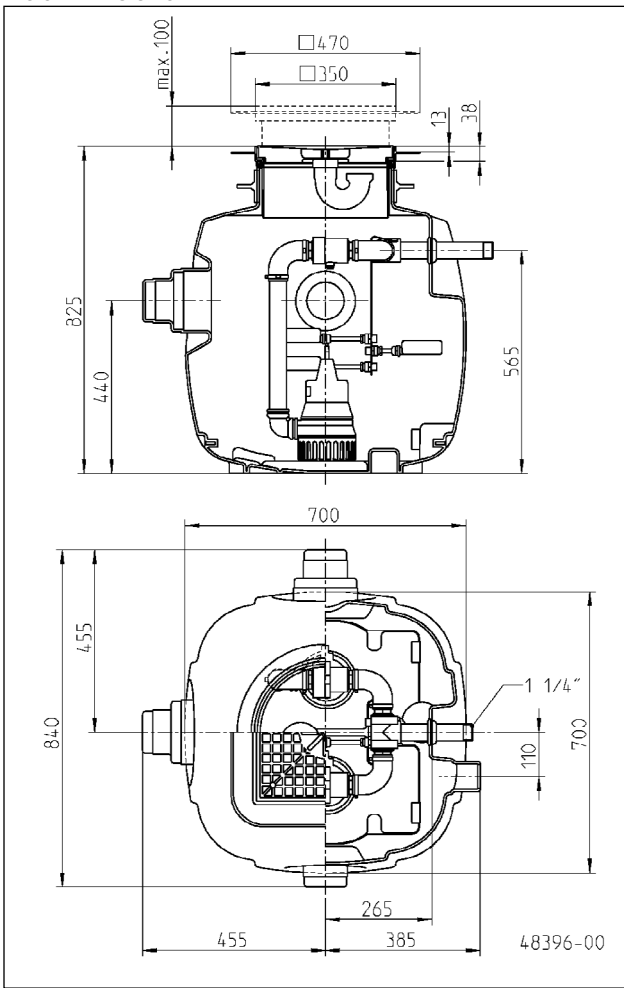

Baufix 200-50

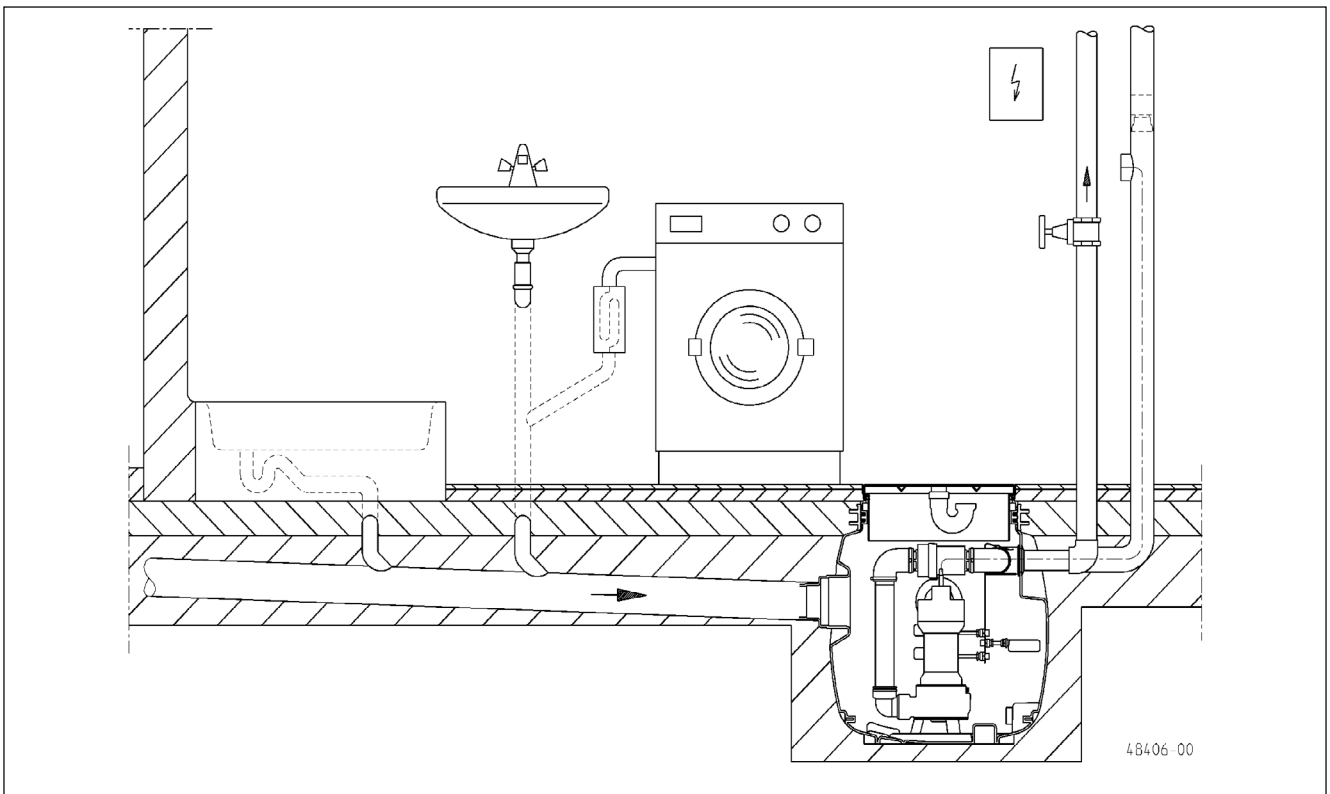
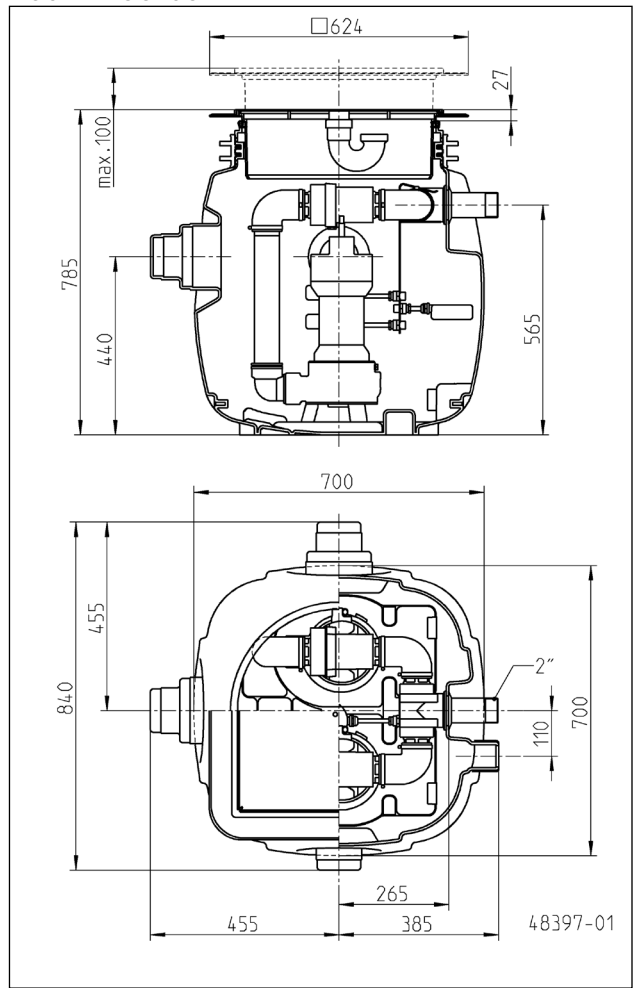

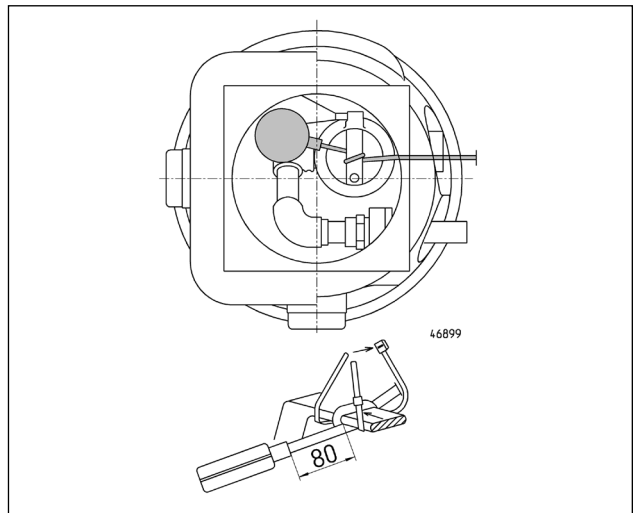
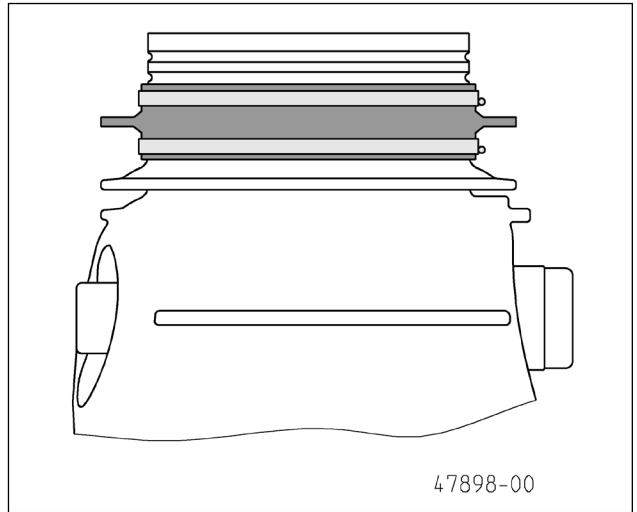
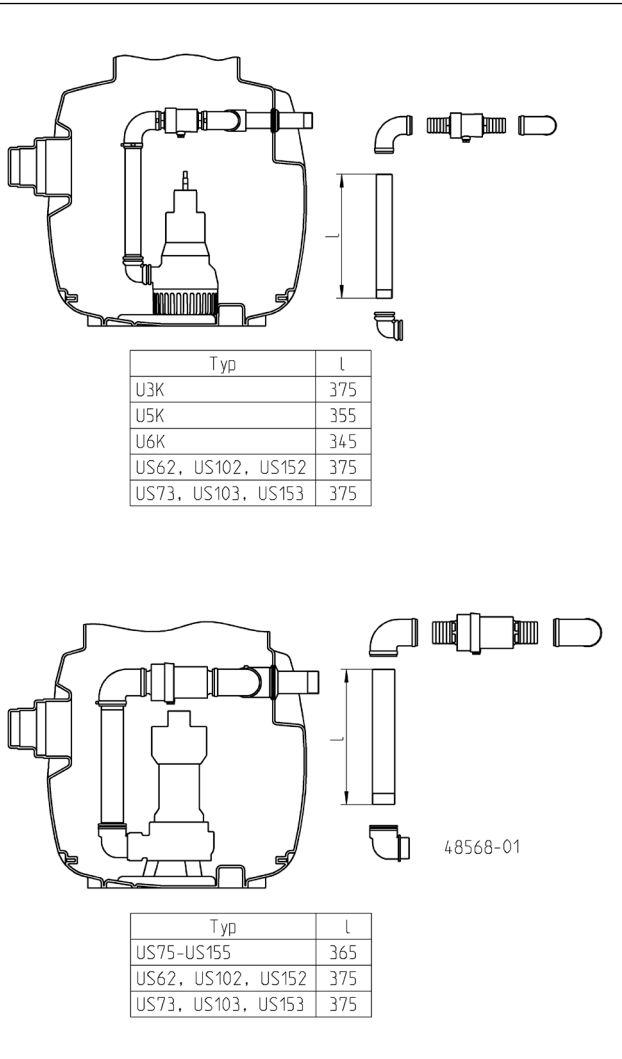

You have purchased a product made by Pentair Jung Pumpen and with it, therefore, also excellent quality and service. Secure this service by carrying out the installation works in accordance with the instructions, so that our product can perform its task to your complete satisfaction. Please remember that damage caused by incorrect installation or handling will adversely affect the guarantee. Therefore please adhere to the instructions in this manual!

This appliance can be used by children aged 8 years or over and by persons with limited physical, sensory or intellectual capabilities, or with limited experience and knowledge, provided that they are supervised or have been instructed in the safe use of the appliance and are aware of the dangers involved. Children must not be allowed to play with the appliance. Cleaning and user maintenance must not be carried out by children unless they are supervised.

Damage prevention in case of failure

Like any other electrical device, this product may fail due to a lack of mains voltage or a technical defect.

If damage (including consequential damage) can occur as a result of product failure, the following precautions can be taken at your discretion:

- Installation of a water level dependent (under circumstances, mains-independent) alarm system, so that the alarm can be heard before damage occurs.
- Inspection of the collecting tank/chamber for tightness up to the top edge before – or at the latest, during – installation or operation of the product.
- Installation of backflow protection for drainage units that can be damaged by wastewater leakage upon product failure.
- Installation of a further product that can compensate in case of failure of the other product (e.g. duplex unit).
- Installation of an emergency power generator.

As these precautions serve to prevent or minimise consequential damage upon product failure, they are to be strictly observed as the manufacturer's guideline – in line with the standard DIN EN specifications as state of the art – when using the product (Higher Regional Court Frankfurt/Main, Ref.: 2 U 205/11, 06/15/2012).

SAFETY INSTRUCTIONS

This instruction manual contains essential information that must be observed during installation, operation and servicing. It is therefore important that the installer and the responsible technician/operator read this instruction manual before the equipment is installed and put into operation. The manual must always be available at the location where the pump or the plant is installed.

Failure to observe the safety instructions can lead to the loss of all indemnity.

In this instruction manual, safety information is distinctly labelled with particular symbols. Disregarding this information can be dangerous.



General danger to people



Warning of electrical voltage

NOTICE! Danger to equipment and operation

Qualification and training of personnel

All personnel involved with the operation, servicing, inspection and installation of the equipment must be suitably qualified for this work and must have studied the instruction manual in depth to ensure that they are sufficiently conversant with its contents. The supervision, competence and areas of responsibility of the personnel must be precisely regulated by the operator. If the personnel do not have the necessary skills, they must be instructed and trained accordingly.

Safety-conscious working

The safety instructions in this instruction manual, the existing national regulations regarding accident prevention, and any internal working, operating and safety regulations must be adhered to.

Safety instructions for the operator/user

All legal regulations, local directives and safety regulations must be adhered to.

The possibility of danger due to electrical energy must be prevented.

Leakages of dangerous (e.g. explosive, toxic, hot) substances must be discharged such that no danger to people or the environment occurs. Legal regulations must be observed.

Safety instructions for installation, inspection and maintenance works

As a basic principle, works may only be carried out to the equipment when it is shut down. Pumps or plant that convey harmful substances must be decontaminated.

All safety and protection components must be re-fitted and/or made operational immediately after the works have been completed. Their effectiveness must be checked before restarting, taking into account the current regulations and stipulations.

Unauthorised modifications, manufacture of spare parts

The equipment may only be modified or altered in agreement with the manufacturer. The use of original spare parts and accessories approved by the manufacturer is important for safety reasons. The use of other parts can result in liability for consequential damage being rescinded.

Unauthorised operating methods

The operational safety of the supplied equipment is only guaranteed if the equipment is used for its intended purpose. The limiting values given in the "Technical Data" section may not be exceeded under any circumstances.

Instructions regarding accident prevention

Before commencing servicing or maintenance works, cordon off the working area and check that the lifting gear is in perfect condition.

Never work alone. Always wear a hard hat, safety glasses and safety shoes and, if necessary, a suitable safety belt.

Before carrying out welding works or using electrical devices, check to ensure there is no danger of explosion.

People working in wastewater systems must be vaccinated against the pathogens that may be found there. For the sake of your health, be sure to pay meticulous Notice to cleanliness

wherever you are working.

Make sure that there are no toxic gases in the working area.

Observe the health and safety at work regulations and make sure that a first-aid kit is to hand.

In some cases, the pump and the pumping medium may be hot and could cause burns.

For installations in areas subject to explosion hazards, special regulations apply!

USE

The sump BAUFIX 200 is a conventional effluent collecting sump in conjunction with separately ordered pumps.

NOTICE! The Baufix must not be used in groundwater endangered areas unless it is fitted with the "groundwater seal" accessory, up to a maximum pressure load of 3 m water column.

The screwed cover is smell-tight and level compensating. The integrated and smell-tight floor drain can be opened on request. Depending on the power requirement, various pump types can be installed:

Baufix 200-32: U3K, U5K, U6K, US 62, US 73, US 102, US 103, US 73 Ex oder US 103 Ex

Baufix 200-50: US 62, US 73, US 75, US 102, US 103, US 105, US 155, US 73 Ex or US 103 Ex.

The second pump is a reserve pump, according to EN 12056. One pump must be able to cope with the maximum inflow on its own.

NOTICE! In some countries it must not be used for pumping sewage water from lavatories.

The allowed temperature of the pumped medium is 35 °C, short time period 60°C.

The tank has two inlet connections DN 100/150 at the side at 90° to each other, a DN 100 inlet connection, a threaded connection (1 1/4" or 2") for the pressure pipe, and a DN 70 ventilation connection.

Extent of delivery

Baufix underfloor tank, in-tank pressure pipe, swing-type check valves, cover frame, gasket and cover plate with closing plug.

Closing plug for cable inlet, 4 hose connectors, 8 hose clips, PP pipe, profiled seal, complete siphon, 2 90° bends, damp-room seal.

Electrical Connection

Please refer to the relevant instructions in the manual for the pump.

MOUNTING

The pressure pipe must be taken in a loop over the local back-pressure level and secured with a reflux valve (EN 12056). The reflux valves are supplied with the Baufix 200.

Accessory Groundwater seal

Fix the wall collar to the Baufix with the two strap retainers as a sealant against groundwater.

Installing the tank

1. Affix the sealing profile with the clamping area on the neck of the tank, taking care that the sealing cross-section (with the sealing lips) is facing inwards. Brush the seal with a mounting aid (such as technical Vaseline) and insert the cover frame into the neck of the tank, initially at an angle, and then press the remainder in. The air should audibly escape from the seal and the cover frame should be securely in place. After assembling the frame, check that the seal is correctly positioned on the tank. If necessary, repeat the assembly of the frame if the seal is rolled up.
2. Saw open and deburr the inlet connections at the marked place (cap). Connect the inlet pipe and ventilation pipe with a KG pipe socket component (to be supplied by the user).
3. Connect up the pressure pipe. **Notice!** During sealing and screwing operations, the pressure pipe in the tank must not be allowed to twist. Use pliers, if necessary, to prevent it from turning.
4. After connecting the required pipes, align the Baufix 200 and fill in with earth. The entire cover must remain in the Baufix to prevent dirt from getting in.
5. Fix the tank in place and concrete it in, so that it finishes flush with the top edge. **Notice!** Do not concrete the cover frame in place. The height of this cover frame must remain freely adjustable by up to 100 mm and so be able to match the level of any flooring planned (screed, tiles).
6. Before constructing the flooring, adjust the cover frame to the intended height. The clamping action of the seal will hold it in place.
7. After the screed has set, the enclosed square seal is bonded to the integrated sealing strip. After the customer has attached a further thin-bed waterproofing system, the area can be tiled. **Information** on sealants and adhesives can be found in the information sheet on "Composite sealing" issued by the professional association of the German tile industry within the German Construction Confederation (ZDB).

Mounting the pumps

1. Cut the pressure pipes to size (see illustration).
2. Connect the pressure pipes to the pumps with the bends and hose connectors. Seal and screw tight.
3. Place the pumps into the tank and use the hose connectors to make the pipe, check valve and T piece connections. Tighten the clamps.
4. Pull the cables up to the T-piece through the vent pipe. Enough cable has to be in the tank to allow the pumps to be pulled out of the tank for servicing. The T-piece can then be sealed with the slotted plug.

Installation with a single pump

If the Baufix is to be fitted initially with just one pump, we recommend using the pump model fitted with a float switch.

The single pump must be positioned in the tank with the float pointing towards the centre of the tank.

Remove the hose connector from the free branch of the T-piece and replace the connector with the blind plug included in the package.

NOTICE! The mains plug need not be cut off when you feed it up through the ventilation pipe.

Installing the float switch set

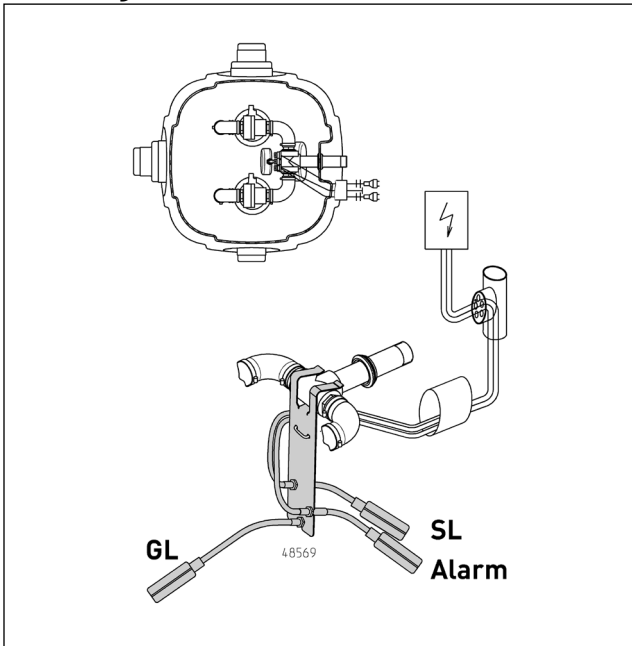

GL-Base load | Alarm | SL-Peak load

NOTICE! Do not alter the length of the cables that run from the float switch to the retaining plate. The lengths have already been adjusted.

Push the ready-to-install float switch set onto the centre of the T-piece. Secure the pump cables and float switch cables adequately in the tank, so that the float switches can float up unhindered. Feed the float switch cables up through the ventilation pipe (in the same way as the pump cables) to the T-piece provided by the customer, then through the closing plug to the control unit, ensuring that the seal is odour-tight.

Installation of floor drain

1. Take out the screws of the cover plate and remove it.
2. Take the plug out of the cover connection piece with a screwdriver.
3. Screw the siphon with the union nut, the packing and the expanding ring on the connection piece.
4. The outlet of the siphon must not be positioned directly above the pumps.
5. Grease the screws, ensure the correct position of the profiled seal and screw down the cover plate again.

Accessory alarm device (only single unit)

The alarm device signals an excessive high water level. It can be installed subsequently. The float switch is fixed to the pump handle (see the drawing at the front). The cable is pulled through the vent pipe and sealed in the same way as the pump cable. The alarm unit should be connected to a separate electric circuit, to ensure the operation in case of a pump fault. Alternatively it can be equipped with our 9V-rechargeable battery for off the line operation.

Accessory special ventilation

If the ventilation over the roof level is not possible, alternatively the special ventilation consisting of a ventilation screen and 3 activated carbon filters can be installed above the T-piece for

the cable in the ventilation pipe. An assembly instruction accompanies the special ventilation.

Accessory guide rail system

For the pumps is as an accessory guide rail system available that can be mounted in the Baufix. A simple pull out and lowering the pump is possible.

Accessory: sump extension

With the sump extension, the installation depth of the Baufix 200-50 can be increased by between 165 and 265 mm. However, the pumps must still remain accessible for installation and maintenance works (arm length).

Accessory: tileable cover plate

A stainless-steel cover plate for tiling is available for the Baufix 200-32. The cover plate has an integrated base drain.

MAINTENANCE

The tank, the float switches and the foot strainer of the pump should be inspected regularly and cleaned if necessary.

To service the pump, please refer to the separate operating instruction.

NOTICE! Always grease the screws before using them to close the cover plate and ensure the correct position of the profiled seal.



BAUFIX 200-32 (JP48186) • BAUFIX 200-50 (JP48187)

Spare parts

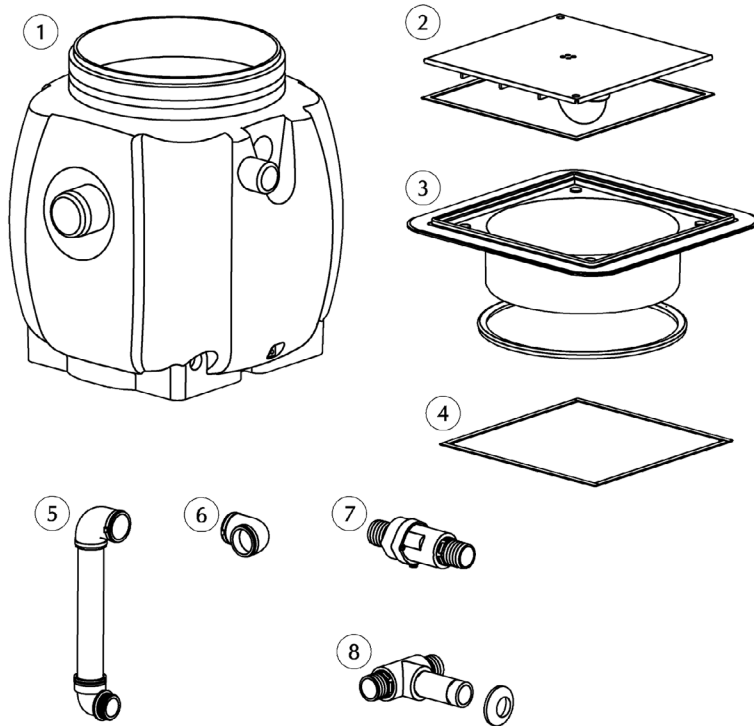

Baufix 200-32			
①	Behälter	Sump	JP48707
②	Abdeckplatte	Cover	JP48245
③	Abdeckrahmen	Frame	JP48244
④	Dichtprofil	Profiled joint	JP47394
⑤	Druckleitung	Pressure pipe	JP48739
⑥	Gummi-Winkel	Rubber elbow	JP48460
⑦	Rückschlagklappe	Reflux valve	JP48716
⑧	Anschluss DN32	Connection DN32	JP48721

Baufix 200-50			
①	Behälter	Sump	JP48708
②	Abdeckplatte	Cover	JP48836
③	Abdeckrahmen	Frame	JP48835
④	Dichtprofil	Profiled joint	JP48837
⑤	Druckleitung	Pressure pipe	JP48717
⑥	Gummi-Winkel	Rubber elbow	JP48461
⑦	Rückschlagklappe	Reflux valve	JP48718
⑧	Anschluss DN50	Connection DN50	JP48722



**PUMP TECHNICAL
SERVICES LIMITED**

