



COMPLI

300 E		1010/4 BWE
	510/4 BW	1010/4 BW
400 E	515/4 BW	1015/4 BW
400	525/4 BW	1025/4 BW
425/2 BW	525/2 BW	1025/2 BW
435/2 BW	535/2 BW	1035/2 BW
108/2 ME	508/2 ME	1008/2 ME
108/2 M	508/2 M	1008/2 M
120/2 M	520/2 M	1020/2 M

EN Instruction Manual

You have purchased a product made by Pentair Jung Pumpen and with it, therefore, also excellent quality and service. Secure this service by carrying out the installation works in accordance with the instructions, so that our product can perform its task to your complete satisfaction. Please remember that damage caused by incorrect installation or handling will adversely affect the guarantee. Therefore please adhere to the instructions in this manual!

This appliance can be used by children aged 8 years or over and by persons with limited physical, sensory or intellectual capabilities, or with limited experience and knowledge, provided that they are supervised or have been instructed in the safe use of the appliance and are aware of the dangers involved. Children must not be allowed to play with the appliance. Cleaning and user maintenance must not be carried out by children unless they are supervised.

Damage prevention in case of failure

Like any other electrical device, this product may fail due to a lack of mains voltage or a technical defect.

If damage (including consequential damage) can occur as a result of product failure, the following precautions can be taken at your discretion:

- Installation of a water level dependent (under circumstances, mains-independent) alarm system, so that the alarm can be heard before damage occurs.
- Inspection of the collecting tank/chamber for tightness up to the top edge before – or at the latest, during – installation or operation of the product.
- Installation of backflow protection for drainage units that can be damaged by wastewater leakage upon product failure.
- Installation of a further product that can compensate in case of failure of the other product (e.g. duplex unit).
- Installation of an emergency power generator.

As these precautions serve to prevent or minimise consequential damage upon product failure, they are to be strictly observed as the manufacturer's guideline – in line with the standard DIN EN specifications as state of the art – when using the product (Higher Regional Court Frankfurt/Main, Ref.: 2 U 205/11, 06/15/2012).

SAFETY INSTRUCTIONS

This instruction manual contains essential information that must be observed during installation, operation and servicing. It is therefore important that the installer and the responsible technician/operator read this instruction manual before the equipment is installed and put into operation. The manual must always be available at the location where the pump or the plant is installed.

Failure to observe the safety instructions can lead to the loss of all indemnity.

In this instruction manual, safety information is distinctly labelled with particular symbols. Disregarding this information can be dangerous.



General danger to people



Warning of electrical voltage

NOTICE! Danger to equipment and operation

Qualification and training of personnel

All personnel involved with the operation, servicing, inspection and installation of the equipment must be suitably qualified for this work and must have studied the instruction manual in depth to ensure that they are sufficiently conversant with its contents. The supervision, competence and areas of responsibility of the personnel must be precisely regulated by the operator. If the personnel do not have the necessary skills, they must be instructed and trained accordingly.

Safety-conscious working

The safety instructions in this instruction manual, the existing national regulations regarding accident prevention, and any internal working, operating and safety regulations must be adhered to.

Safety instructions for the operator/user

All legal regulations, local directives and safety regulations must be adhered to.

The possibility of danger due to electrical energy must be prevented.

Leakages of dangerous (e.g. explosive, toxic, hot) substances must be discharged such that no danger to people or the environment occurs. Legal regulations must be observed.

Safety instructions for installation, inspection and maintenance works

As a basic principle, works may only be carried out to the equipment when it is shut down. Pumps or plant that convey harmful substances must be decontaminated.

All safety and protection components must be re-fitted and/or made operational immediately after the works have been completed. Their effectiveness must be checked before restarting, taking into account the current regulations and stipulations.

Unauthorised modifications, manufacture of spare parts

The equipment may only be modified or altered in agreement with the manufacturer. The use of original spare parts and accessories approved by the manufacturer is important for safety reasons. The use of other parts can result in liability for consequential damage being rescinded.

Unauthorised operating methods

The operational safety of the supplied equipment is only guaranteed if the equipment is used for its intended purpose. The limiting values given in the "Technical Data" section may not be exceeded under any circumstances.

Instructions regarding accident prevention

Before commencing servicing or maintenance works, cordon off the working area and check that the lifting gear is in perfect condition.

Never work alone. Always wear a hard hat, safety glasses and safety shoes and, if necessary, a suitable safety belt.

Before carrying out welding works or using electrical devices, check to ensure there is no danger of explosion.

People working in wastewater systems must be vaccinated against the pathogens that may be found there. For the sake of your health, be sure to pay meticulous attention to cleanliness wherever you are working.

Make sure that there are no toxic gases in the working area.

Observe the health and safety at work regulations and make sure that a first-aid kit is to hand.

In some cases, the pump and the pumping medium may be hot and could cause burns.

For installations in areas subject to explosion hazards, special regulations apply!

AREAS OF APPLICATION

The ready to connect Compli sewage lifting stations are TÜV certified and are suitable for the disposal of wastewater from toilets and urinals, and domestic wastewater containing the usual impurities.

The units have a level controller that switches the pump on and off depending on the level of the water. An integrated alarm system beeps if there is a malfunction, even if this is only temporary.

If the pump overheats, the motor cuts out due to the winding thermostat. After the thermostat has switched off the system, pull out the mains plug before remedying the fault, since the device can switch itself on again automatically if the power is still connected. A direct malfunction message is not generated.

The tanks can withstand submersion to a depth of not more than 2 m of water and a submersion period of up to 7 days.

The control unit cannot withstand submersion, but is splash-proof in accordance with IP 44.

If installed in Compliance with the regulations and used properly, then this control unit meets the protective requirements of the EMC Directive 2014/30/EU and is suitable for domestic use and connection to a power supply from the grid. When connected to an industrial mains within an industrial operation with power supply provided by a company-own high-voltage transformer, insufficient immunity to interference has to be expected.

When using the pumps, the relevant national laws, regulations and stipulations must be adhered to, for example:

- Sewage disposal units for building and ground drainage systems (e.g. EN 12050 and 12056 in Europe)
- Installation of low voltage systems (e.g. VDE 0100 in Germany)
- Safety and working materials (e.g., BetrSichV and BGR 500 in Germany)
- Safety in wastewater systems (e.g., GUV-V C5, GUV-R 104 and GUV-R 126 in Germany)
- Electrical systems and operating resources (e.g., GUV-V A3 in Germany)
- Explosion protection EN 60079-0, EN 60079-1, EN 60079-14, EN 60079-17 and EN 1127-1

Scope of supply

- Tank with pump(s)
- Clamp flange / socket for inlet
- Reducing adapter for inlet DN 150 to DN 100
- Slip-on socket pipe for ventilation pipe

- Connection flange for pressure pipe
- Reducing adapter for pressure pipe DN 100 to DN 80
- Non-return valve for the pressure pipe (Compli 100, 300, 500, and 1000)
- Flexible connection with hose clamps for the pressure pipe
- Plug-in seal(s) for the diaphragm hand pump or additional inlet DN 50
- Fixing materials for tank
- Control



NOTICE! Transport lock = protection against buoyancy of the container

Mode of operation: intermittent operation S3; see "Technical Data".

INSTALLATION

The pump must be installed so that it is buoyancy-proof and free-standing. At least 60 cm free working space must be provided around and above the parts that require access for operation or maintenance.

Ventilation: The ventilation pipe must be vented above roof level.

Inlet: A wastewater sluice valve must be installed in the inlet at the front of the tank.

Pressure pipe: A further wastewater sluice valve must be installed behind the non-return valve in the pressure pipe. If the non-return valve is not included in the scope of delivery of the pumping unit, then an EN certified swing-type check valve must be fitted.

The pressure pipe must be laid in a loop above the local backup level.

NOTICE! The pressure pipe of the Compli 300/400 must be supported or suspended by the customer. The weight must not rest on the system.

A pump sump must be provided to facilitate the disposal of water from the pump installation area.

NOTICE! All bolts that are used for fixing individual components to the tank should be tightened with a torque of no more than 6 Nm.

Installing the tank

Compli 300. Close the sluice valve in the inlet (accessory) to prevent any leakage of water during the installation work.

Select the DN 100 inlet you wish to use and open this inlet at the side or at the top at the markings using a 102 Ø hole saw or a jigsaw. Then deburr the edges. Fix the enclosed clamp flange loosely to the inlet with the hexagon screws.

Take the brackets that are used to fix the unit in place and screw them to the tank. Then take the unit with the clamp flange and push it onto the inlet pipe as far as it will go.

Mark the positions of the wall plugs on the floor, then drill the holes and push in the wall plugs.

Now the clamp flange can be tightened and the unit can be anchored to the floor using the wood screws and shims.

Compli 400. Close the sluice valve in the inlet (accessory) to prevent any leakage of water during the installation work.

The inlet height is continuously adjustable, see technical data.

The unit must be slid onto the inlet pipe as far as possible and then aligned.

If a DN 100 side inlet is used, the inlet must first be opened at the marked position using a hole saw, Ø 102, and then deburred. The standard inlet must then be closed using a closure kit (accessory) and the switch-on level must be reset.

Slide the floor fixings into the side "pockets" of the tank and then anchor them to the floor with the plugs and screws.

All other Compli. Close the sluice valve in the inlet (accessory) to prevent any leakage of water during the installation work.

Units must be slid onto the inlet pipe, together with the clamp flange, as far as possible and then aligned.

If a DN 150 side inlet is used, the inlet must first be opened at the marked position using a hole saw, Ø 152, and then deburred. The standard inlet must then be closed using a closure kit (accessory) and the switch-on level must be reset.

In the case of Compli 500 and 1000, the inlet can be reduced from DN 150 to DN 100 if the enclosed reducer is first of all fitted to the clamp flange.

Tighten the hexagon screws on the clamp flange.

Mark the positions of the holes for fixing the tank to the floor, then drill the holes.

Insert the wood screw, together with the washer and wall plug, into the drill hole in the tank and tighten it.

NOTICE! Ensure that the tank does not become deformed due to overtightening the screws, otherwise this could result in leakage.

Installing the ventilation

Connect the ventilation pipe to the top right of the tank using the DN 70 slip-on socket pipe and vent it above roof level.

Installing the pressure pipe

Compli 300.

NOTICE! For simplified maintenance of the non-return valve

Fit the following to the non-return valve:

1. Discharge flange
2. Flexible connector
3. Connection flange (by customer, min. 200 long)
4. Stop valve (accessory)
5. Connect the pressure pipe and loop it over the local backup level.

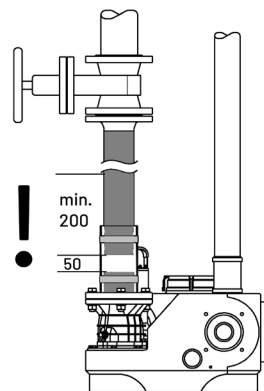

Compli 400

NOTICE! When replacing a compli 400 with horizontal pressure line, the elastic connection can be shortened.

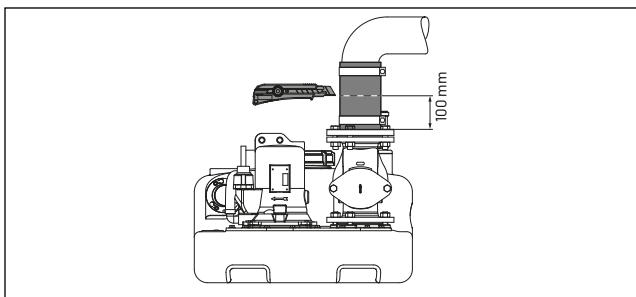

All other Compli. Fit the following to the discharge flange:

1. Non-return valve (if not included in scope of supply)
2. Stop valve (accessory)
3. Connection flange and
4. connect the pressure pipe with the flexible connector and loop it over the local backup level.

Additional connection, DN 50, vertical

This connection is used for emergency disposal.

Open the pipe connection at the marking using a hole saw, deburr the edges. and put the plug-in seal, 58/50, into place.

- Mounting Compli emergency supply connection (accessory)
- Mounting hand diaphragm pump (accessory)

Push the inlet pipe, with an external diameter of 50 mm, into the tank through the plug-in seal. The distance from the bottom of the tank must be at least 50 mm.

Fix the diaphragm hand pump to the wall in an easily accessible position. Connect it to the pushed-in pipe and then connect the pressure pipe to the diaphragm hand pump. Here, too, the pressure pipe must be looped over the local backup level.

Additional inlet, DN 50, horizontal

Using a hole saw, open the additional inlet by cutting along the pre-cut groove. Deburr the edges.

Put the plug-in seal, 58/50, into place.

Push the inlet pipe, with an external diameter of 50 mm, into the tank through the plug-in seal.

NOTICE! The pipes that connect to the low-level inlets on the side of the unit must be fitted with a bend, as close to the unit as possible. The pipe invert of this bend must be at a height of at least 180 mm above the floor on which the unit is fixed. Air pockets in the connecting pipe can cause run-off problems and the water could back-up. To prevent back-ups, the inlet pipe must be vented at its highest point. The ventilation pipe can be connected into the tank ventilation.

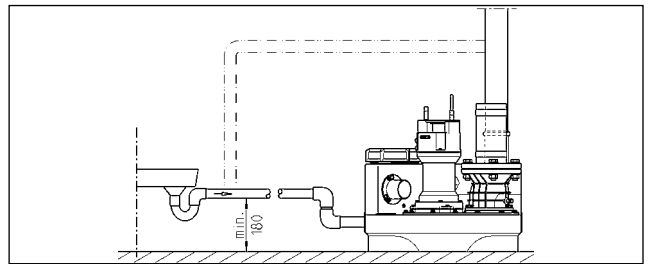

Installing control unit

NOTICE! Only qualified electricians may carry out electrical works to the pump or the controls.

NOTICE! Never put the mains plug in water! If water gets into the plug, this can cause malfunctions and damage.

Not compli 300. Only operate the control unit in dry rooms and keep the housing closed at all times. The control unit must be easily accessible to enable it to be checked at any time. High humidity and condensation can destroy the controls!

Alternating current (AC) units

Only connect the pump to electrical sockets that have been installed properly in a dry room, in accordance with the regulations, and are fitted with at least a 16 A (delay) fuse.

Three-phase current units

For the electrical connection of the sewage disposal unit, a five pole CEE power socket is required. This must be located in a dry room (3/N/PE~230/400 V).

NOTICE! Only slow-blow fuses or automatic fuses with C characteristics are to be used as pre-fuses for the pump.

Switching levels

The switch-on and switch-off points have been factory set for the standard inlet height for the units. If you select a different inlet height, then you must redefine the switch-on point. The other switching points for the alarm and peak load are then reset automatically by the control unit.

Redefining the switch-on level



Loosen the three screws and turn the lid all the way to the left, counterclockwise.

Fill the tank with water up to the desired switch-on level. Carefully turn the lid clockwise until the pump starts.

Now tighten the three screws again, the new switch-on level is set.

Alarm

- In the case of Compli 300, the runtime is monitored. If the pumping process takes longer than 50 +/- 5 seconds, an alarm is triggered. Pull the plug to acknowledge the alarm.
- All other Compli. Malfunction messages are given both optically as well as acoustically. The standard mains-dependent alarm system reports motor faults in the pump and high water. At the same time a built-in acoustic alarm sounds. In the case of the Compli 1000, this acoustic signal can only be turned off by rectifying the fault. On the Compli 100, 400 and 500, the signal can be acknowledged with the "RESET" button on the housing.
- If an acoustic signal would be inappropriate at the installation site in question, an alarm signal can be relayed via the potential-free contact (terminals 40 and 41) on the circuit board (in the plug in the case of Compli 300). The potential-free contact of the centralised alarm can be loaded with a maximum of 5 A / 250 VAC. The contact opens after the fault has been remedied.

Battery pack for alarm system

Not compli 300. The alarm device is mains-dependent in its standard version, i.e. it is not possible to trigger a high-water alarm in the event of a power failure. To enable the alarm device to work even if there is a power failure, a rechargeable battery pack must be used. Open the door. Connect the battery pack to the connection clip, and use the existing cable ties to attach it to the intended position (G1) on the PCB. The battery pack can supply the alarm system with power for about 1 hour in case of permanent alarm.

After return of the mains voltage, the battery pack is charged again automatically. An empty battery is ready for operation within approx. 24 hours. It is fully charged after about 100 hours.

Check the function of the battery pack at regular intervals! To

do so, disconnect the unit from the mains and trigger a high-water alarm. The volume of the acoustic signal must not become significantly quieter over a period of several minutes. The service life is about 5 years. Note the insertion date on the battery pack and after five years the battery pack should be replaced as a precautionary measure.

CAUTION!

Only use the 9V-NiMH battery supplied by the manufacturer! If dry-cell batteries or Lithium batteries are used there is a danger of explosion!

Shutting down the internal alarm buzzer

Not compli 300. Remove the sealed jumper (BRX/BRX1). To prevent the jumper from getting lost, attach it to a pin of the two-pole pin connector.

Accessory: External alarm buzzer

Open the door of the control unit.

An additional separate acoustic 12 VDC signal transmitter with a current consumption of not more than 30 mA can be connected to terminals "S+" and "S-". The internal alarm buzzer can either be switched on or off.

In the case of compli 300, a mains-independent alarm device can be fitted as an accessory. There is a mounting base on the tank for this purpose.

Accessory: Separate high water level sensor

A separate high-water level sensor can be fitted on the compli 400, which triggers an additional high-water alarm acoustically and visually (LED AUX input). A mounting base is provided on the tank. The connection to the control unit is made via the AUX input (clamps 51 and 52). The alarm goes off when the water level in the tank has fallen.

Accessory: Time meter

An optional time meter can be fitted in the control unit (not compli 300). To do so, shorten the connections of the time meter to approx. 8 mm and insert them into the four sockets at location BSZ on the printed circuit board. If there is no time meter indication after switching on the unit again, rotate the time meter through 180°.

Accessory Compli 1000: External 230V~ flashing light or warning light

Connect a 230V~ lamp (1 A max.) to terminals N and 41.

Lay an insulated wire bridge from terminal U~ to terminal 40. The electric circuit is protected by F1.

Set Jumper BRX2 as follows: Flashing light without BRX2 (Continuous ===) Warning light with BRX2 (Flashing (-|-|-|-))

Test run and functional check

1. Open the maintenance cover of the tank.
2. Open the shut-off valves in the inlet and the pressure pipe.
3. Connect the unit to the power supply and observe the indication for the rotating field direction.
4. Fill the tank up to the switch-on level.
5. The pump will now switch on and empty the tank. Observe the pumping process through the maintenance opening.

6. Lift the float of the level controller slowly by hand until it is above the switch-on point and hold it there until the alarm is triggered.
7. Then close the maintenance opening with the cover and seal.
8. Check to ensure that the tank, fittings and pipes are water-tight, by carrying out several switching runs.

OPERATION

Automatic operation

Automatic operation is the normal operating mode of the unit. The rocker switch must be set to "Automatic". The integrated level controller switches the pump on and off depending on the water level in the tank. A green LED lights up when the pump is operating (in the case of Compli 300 when it is ready for operation).

NOTICE! If unusually large quantities of wastewater flow into the unit (e.g. when a pool is drained), partially close the shut-off valve at the inlet until the unit can operate normally again, switching on and off, (S3 Intermittent duty, not pumping continuously, since this could overheat the pump motor).

Manual operation

Set the rocker switch to "Hand". The pump will now operate permanently and independently of the wastewater level. The pumping out operation should therefore be observed through the maintenance opening.

Shutting down

Set the rocker switch to "0". This shuts down the pump. The alarm system remains ready for operation.

DANGER!

Do not use the position "0" of the selector switch for repair and maintenance work on the control and pump, but always unplug the unit from the mains.

Inspection

To maintain operational reliability, carry out a visual inspection of the unit, including the pipe connections, once a month.

MAINTENANCE

Maintenance and inspection of this product must be carried out in accordance with EN 12056-4. To ensure continued reliability of service, we recommend that you take out a service contract.

NOTICE! The maintenance of the sewage lifting station and maintenance measures are carried out by specialists at intervals of 3 months in commercial premises, multi-family homes in 6 months or 12 months in family homes.

WARNING!

Before carrying out any works: disconnect the pump and the controls from the mains and take steps to ensure that they cannot be energized again.

WARNING!

Check the cable for mechanical or chemical damage. Damaged or kinked cables must be replaced by the manufacturer.

We recommend that the following works be included in the service:

1. Check the connection points for watertightness and inspect the areas surrounding the unit and the fittings.
2. Operate the shut-off valves and check that they move easily. Adjust and grease them if necessary.
3. Open and clean the swing-type check valve; check the seat and valve (ball)
4. Clean the pump and the pipes where they connect to the unit; check the impeller and the bearings.



CAUTION!

Worn impellers can have sharp edges.

5. Oil check. If necessary top up or change oil (if oil chamber available).
6. Clean the inside of the tank (as necessary, or if especially required); remove any grease, for example.
7. Check the condition of the collecting tank.
8. Flush the system through with water once every 2 years.
9. Inspect the electrical section of the unit. The control unit itself is maintenance-free, but if a rechargeable battery is fitted, then it should be checked regularly to ensure that it is in good working order. To do so, unplug the unit from the mains and lift the float of the level controller slowly by hand and hold it there until the alarm is triggered.
10. In addition, clean the float if necessary.

When all the servicing tasks have been performed, carry out a test run and then put the unit back into operation. The service must be documented, giving details of the important data and of all the tasks carried out.

Resetting the maintenance reminder (if available)

  Set switches S3 and S4 on the control unit circuit board to  the up position (RESET ON). After approximately 3 seconds P6 will flash 3 times.

(If the switches remain in position, the maintenance reminder is deactivated).

Now set the new reminder interval

1 year  , 1/2 year  or 1/4 year  .

Oil check

(Only applies for units 08/2, 20/2, 25/2 and 35/2). First of all, unscrew the hexagon screws or Allen screws around the pump and lift the pump and impeller off the tank. The drain plug is labelled "Öl". In order to check the mechanical seal, the oil, including any residue, must be drained from the oil reservoir and collected in a clean measuring container.

- If the oil is contaminated with water (milky), an oil change must be carried out. Check again after a further 300 operating hours, but at the very latest after 6 months!
- However, if the oil is contaminated with both water and pollutants, then not only the oil must be replaced, but the mechanical seal as well.

For monitoring the oil reservoir, it is also possible to retrofit the electrode of our "DKG" seal leak detector in place of the "DKG" sealing screw.

Changing the oil

(Only applies for units 08/2, 20/2, 25/2 and 35/2). To ensure operational liability, the first oil change should be carried out after 300 operating hours, with further oil changes carried out after every 1000 operating hours.

If the number of operating hours is very low, an oil change should still be carried out at least once a year.

If wastewater with strongly abrasive constituents is being pumped, the oil changes should be carried out at correspondingly shorter intervals.

Use HLP hydraulic mineral oil, viscosity class 22 to 46, e.g. Mobil DTE 22, DTE 24, DTE 25, to replace the oil in the oil reservoir.

The quantity of oil required is 380 cm³ for the MultiCut pumps UC 08/2 M and UC 20/2 M, and 1000 ml for the MultiFree pumps UC 25/2 BW and 35/2 BW.

NOTICE! The oil reservoir may only be filled with the specified quantity of oil. Overfilling will result in the pump being rendered inoperable.

Checking the cutting clearance

Only for pumps with cutting system. The housing screws for the pump, and the connecting and fixing screws of the installation must be checked to ensure they are fixed securely. They should be tightened if necessary.

If the pump performance decreases, or if increasingly loud noises can be heard during operation, or if the cutting performance decreases (the pump tends to become blocked), the impeller and cutting system must be checked for wear by an expert and replaced if necessary.

Using a suitable tool, e.g. feeler gauge, the cutting clearance between the cutting rotor and the cutting plate can be measured. A cutting clearance of over 0.2 mm must be reduced.

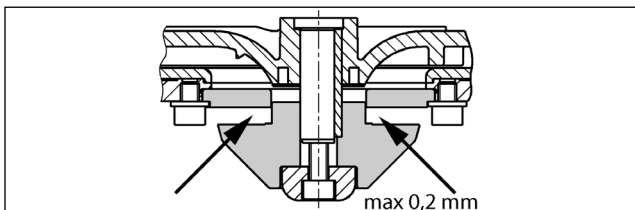

Adjustment of the cutting clearance

1. Block the cutting rotor with a piece of wood and unscrew the central hexagon socket screw.
2. Take off the compression piece, the cutting rotor and an adjusting washer and then attach the compression piece and the cutting rotor again.
3. Block the cutting rotor and tighten again with the hexagon socket screw (tightening torque 8 Nm).
4. Check the freedom of movement of the cutting rotor and the cutting clearance again (max. 0.2 mm).

If the cutting clearance is still too big, a further adjusting washer must be removed. Steps 1-4 must be repeated.

cuit interrupter. Replace defective fuses only with fuses with the same nominal value! If the fuse triggers again, call a qualified electrician or our customer support service.

- The internal 2 A glass tube fuse (delay) for the 230/12V control transformer, the motor contactor and the 230V AC power supply are faulty. Replace defective fuses only with fuses with the same nominal value!
- If the mains cable is damaged, it may only be replaced by the manufacturer.
- If the float switch is obstructed, close the inlet shut-off valve, open the maintenance cover and clear the blockage.

If the alarm is triggered and the unit does not work:

- The thermostat in the motor windings may have switched off the system because the pump is obstructed. In this case, close the shut-off valve at the inlet, drain the tank, pull out the mains plug, remove the pump module, and clear the blockage.

Decreased pumping performance

- Check that the shut-off valve in the pressure pipe is fully open.
- If the pressure pipe is blocked, flush water through the pressure pipe to clear it.
- If the non-return valve is blocked, empty the pressure pipe and clean the non-return valve.
- If the ventilation system is blocked, clean the ventilation hose that leads from the pump tank and check the drilled holes.
- If the unit works normally when it starts pumping, but becomes very loud towards the end, then a qualified electrician must redefine the switch-off point in the control unit.

Indicator "Drehfeld falsch" (Wrong rotating field) lights up

- Mains phase sequence is wrong or phase is absent - thus lower or absent pump delivery. The mains connection must be corrected by a qualified electrician only.

Indicator "Störung Pumpe" (Pump failure) lights up (not compli 300)

- The pump is protected by an integrated circuit breaker which switches off the pump if it overloads or if there is an electric motor fault. After this has been triggered, the control unit has to be opened by a qualified electrician in order to press the reset button.

Indicator "Hochwasser" (High water) lights up (not compli 300)

- Water level in the tank too high because of low pump flow rate or excessive inflow. Remove any obstructions in the pump or pressure pipe and/or eliminate the excessive inflow.

QUICK TIPS FOR REMEDYING FAULTS

The unit isn't working

- Check the mains voltage, the fuse and the ground fault cir-

CE 0197	JUNG PUMPEN GmbH - Industriestr. 4-6 33803 Steinhagen, Germany 20 466.11.2021.10	EN 12050-1:2001; 2015 Station de relevage pour effluents contenant des matières fécales	<ul style="list-style-type: none"> Compli 300 E (JP50076) Compli 1025/4 BW (JP50102) Compli 400 E (JP50081) Compli 1025/2 BW (JP50103) Compli 400 E (JP50082) Compli 1035/2 BW (JP50104) Compli 400 (JP50079) Compli 108/2 ME (JP50088) Compli 400 (JP50080) Compli 108/2 M (JP50089) Compli 510/4 BW (JP50091) Compli 120/2 M (JP50090) Compli 515/4 BW (JP50092) Compli 508/2 ME (JP50096) Compli 525/4 BW (JP50093) Compli 508/2 M (JP50097) Compli 525/2 BW (JP50094) Compli 520/2 M (JP50098) Compli 535/2 BW (JP50095) Compli 1008/2 ME (JP50112) Compli 1010/4 BWE (JP50099) Compli 1008/2 M (JP50113) Compli 1010/4 BW (JP50100) Compli 1020/2 M (JP50114) Compli 1015/4 BW (JP50101) 	Collecte et relevage automatique des eaux usées exemptes de matières fécales et des eaux usées contenant des matières fécales au-dessus du niveau de retournement.
-------------------	--	--	--	--

CE 0197	JUNG PUMPEN GmbH - Industriestr. 4-6 33803 Steinhagen, Germany 20 466.11.2021.10	EN 12050-1:2001; 2015 Lifting plant for wastewater containing faecal matter	<ul style="list-style-type: none"> Compli 300 E (JP50076) Compli 1025/4 BW (JP50102) Compli 400 E (JP50081) Compli 1025/2 BW (JP50103) Compli 400 E (JP50082) Compli 1035/2 BW (JP50104) Compli 400 (JP50079) Compli 108/2 ME (JP50088) Compli 400 (JP50080) Compli 108/2 M (JP50089) Compli 510/4 BW (JP50091) Compli 120/2 M (JP50090) Compli 515/4 BW (JP50092) Compli 508/2 ME (JP50096) Compli 525/4 BW (JP50093) Compli 508/2 M (JP50097) Compli 525/2 BW (JP50094) Compli 520/2 M (JP50098) Compli 535/2 BW (JP50095) Compli 1008/2 ME (JP50112) Compli 1010/4 BWE (JP50099) Compli 1008/2 M (JP50113) Compli 1010/4 BW (JP50100) Compli 1020/2 M (JP50114) Compli 1015/4 BW (JP50101) 	Collection and automatic lifting of wastewater without sewage and wastewater containing faecal matters above the backflow level
-------------------	--	--	--	---

CE 0197	JUNG PUMPEN GmbH - Industriestr. 4-6 33803 Steinhagen, Germany 20 466.11.2021.10	EN 12050-1:2001; 2015 Fäkalienhebeanlage	<ul style="list-style-type: none"> Compli 300 E (JP50076) Compli 1025/4 BW (JP50102) Compli 400 E (JP50081) Compli 1025/2 BW (JP50103) Compli 400 E (JP50082) Compli 1035/2 BW (JP50104) Compli 400 (JP50079) Compli 108/2 ME (JP50088) Compli 400 (JP50080) Compli 108/2 M (JP50089) Compli 510/4 BW (JP50091) Compli 120/2 M (JP50090) Compli 515/4 BW (JP50092) Compli 508/2 ME (JP50096) Compli 525/4 BW (JP50093) Compli 508/2 M (JP50097) Compli 525/2 BW (JP50094) Compli 520/2 M (JP50098) Compli 535/2 BW (JP50095) Compli 1008/2 ME (JP50112) Compli 1010/4 BWE (JP50099) Compli 1008/2 M (JP50113) Compli 1010/4 BW (JP50100) Compli 1020/2 M (JP50114) Compli 1015/4 BW (JP50101) 	Sammeln und automatisches Heben von fäkalienfreiem und fäkalienhaltigem Abwasser über die Rückstauebene
-------------------	--	---	--	---

RÉACTION AU FEU	NPD
ÉTANCHÉITÉ À L'EAU, ÉTANCHÉITÉ À L'AIR	
- Etanchéité à l'eau	satisfaisant
- Étanchéité aux odeurs	satisfaisant
EFFICACITÉ (PERFORMANCE DE RELEVAGE)	
- Refoulement de matières solides	satisfaisant
- Raccords de tuyaux	satisfaisant
- Dimensions minimales des conduites d'aération	satisfaisant
- Débit minimum	satisfaisant
- Passage libre minimal de l'installation	satisfaisant
- Volume utile minimal	satisfaisant
RÉSISTANCE MÉCANIQUE	
- Capacité de charge et stabilité structurelle du collecteur pour une utilisation à l'extérieur des bâtiments	NPD
- Stabilité structurelle du collecteur pour une utilisation à l'intérieur des bâtiments	satisfaisant
NIVEAU SONORE	70 dB(A)
RÉSISTANCE	
- de la stabilité structurelle	satisfaisant
- de la performance de relevage	satisfaisant
- de la résistance mécanique	satisfaisant
SUBSTANCES DANGEREUSES	NPD

REACTION TO FIRE	NPD
WATERTIGHTNESS, AIRTIGHTNESS	
- Water tightness	Pass
- Odour tightness	Pass
EFFECTIVENESS (LIFTING EFFECTIVENESS)	
- Pumping of solids	Pass
- Pipe connections	Pass
- Minimum dimensions of ventilating pipes system	Pass
- Minimum flow velocity	Pass
- Minimum free passage of the plant	Pass
- Minimum useful volume	Pass
MECHANICAL RESISTANCE	
- Load bearing capacity and structural stability of collection tank for use outside buildings	NPD
- Structural stability of collection tank for use inside buildings	Pass
NOISE LEVEL	70 dB(A)
DURABILITY	
- of structural stability	Pass
- of lifting effectiveness	Pass
- of mechanical resistance	Pass
DANGEROUS SUBSTANCES	NPD

BRANDVERHALTEN	NPD
WASSERDICHTHEIT, LUFTDICHTHEIT	
- Wasserdichtheit	Bestanden
- Geruchsdichtheit	Bestanden
WIRKSAMKEIT (HEBEWIRKUNG)	
- Förderung von Feststoffen	Bestanden
- Rohranschlüsse	Bestanden
- Mindestmaße von Lüftungsleitungen	Bestanden
- Mindestfließgeschwindigkeit	Bestanden
- Freier Mindestdurchgang der Anlage	Bestanden
- Mindestnutzvolumen	Bestanden
MECHANISCHE FESTIGKEIT	
- Tragfähigkeit und strukturelle Stabilität des Sammelbehälters für die Verwendung außerhalb von Gebäuden	NPD
- Strukturelle Stabilität des Sammelbehälters für die Verwendung innerhalb von Gebäuden	Bestanden
GERÄUSCHPEGEL	70 dB(A)
DAUERHAFTIGKEIT	
- der Wasserdichtheit und Luftdichtheit	Bestanden
- der Hebewirkung	Bestanden
- der mechanischen Festigkeit	Bestanden
GEFÄHRLICHE SUBSTANZEN	NPD



0197

JUNG PUMPEN GmbH - Industriestr. 4-6 33803 Steinhagen, Germany
20
466.11.2021.10

EN 12050-1:2001; 2015**Instalacja przepompowni fekaliiów**

Compli 300 E (JP50076)	Compli 1025/4 BW (JP50102)
Compli 400 E (JP50081)	Compli 1025/2 BW (JP50103)
Compli 400 E (JP50082)	Compli 1035/2 BW (JP50104)
Compli 400 (JP50079)	Compli 108/2 ME (JP50088)
Compli 400 (JP50080)	Compli 108/2 M (JP50089)
Compli 510/4 BW (JP50091)	Compli 120/2 M (JP50090)
Compli 515/4 BW (JP50092)	Compli 508/2 ME (JP50096)
Compli 525/4 BW (JP50093)	Compli 508/2 M (JP50097)
Compli 525/2 BW (JP50094)	Compli 520/2 M (JP50098)
Compli 535/2 BW (JP50095)	Compli 1008/2 ME (JP50112)
Compli 1010/4 BWE (JP50099)	Compli 1008/2 M (JP50113)
Compli 1010/4 BW (JP50100)	Compli 1020/2 M (JP50114)
Compli 1015/4 BW (JP50101)	

Zbieranie i automatyczne przepompowywanie ścieków bez fekaliiów i ścieków fekalnych powyżej poziomu cofki



0197

JUNG PUMPEN GmbH - Industriestr. 4-6 33803 Steinhagen, Germany
20
466.11.2021.10

EN 12050-1:2001; 2015**Stazione di sollevamento per acque reflue contenenti materiale fecale**

Compli 300 E (JP50076)	Compli 1025/4 BW (JP50102)
Compli 400 E (JP50081)	Compli 1025/2 BW (JP50103)
Compli 400 E (JP50082)	Compli 1035/2 BW (JP50104)
Compli 400 (JP50079)	Compli 108/2 ME (JP50088)
Compli 400 (JP50080)	Compli 108/2 M (JP50089)
Compli 510/4 BW (JP50091)	Compli 120/2 M (JP50090)
Compli 515/4 BW (JP50092)	Compli 508/2 ME (JP50096)
Compli 525/4 BW (JP50093)	Compli 508/2 M (JP50097)
Compli 525/2 BW (JP50094)	Compli 520/2 M (JP50098)
Compli 535/2 BW (JP50095)	Compli 1008/2 ME (JP50112)
Compli 1010/4 BWE (JP50099)	Compli 1008/2 M (JP50113)
Compli 1010/4 BW (JP50100)	Compli 1020/2 M (JP50114)
Compli 1015/4 BW (JP50101)	

Raccolta e sollevamento automatico di acque reflue prive di sostanze fecali e di acque reflue contenenti sostanze fecali al di sopra del livello di ristagno



0197

JUNG PUMPEN GmbH - Industriestr. 4-6 33803 Steinhagen, Germany
20
466.11.2021.10

EN 12050-1:2001; 2015**Fecaliënpompinstallatie**

Compli 300 E (JP50076)	Compli 1025/4 BW (JP50102)
Compli 400 E (JP50081)	Compli 1025/2 BW (JP50103)
Compli 400 E (JP50082)	Compli 1035/2 BW (JP50104)
Compli 400 (JP50079)	Compli 108/2 ME (JP50088)
Compli 400 (JP50080)	Compli 108/2 M (JP50089)
Compli 510/4 BW (JP50091)	Compli 120/2 M (JP50090)
Compli 515/4 BW (JP50092)	Compli 508/2 ME (JP50096)
Compli 525/4 BW (JP50093)	Compli 508/2 M (JP50097)
Compli 525/2 BW (JP50094)	Compli 520/2 M (JP50098)
Compli 535/2 BW (JP50095)	Compli 1008/2 ME (JP50112)
Compli 1010/4 BWE (JP50099)	Compli 1008/2 M (JP50113)
Compli 1010/4 BW (JP50100)	Compli 1020/2 M (JP50114)
Compli 1015/4 BW (JP50101)	

Verzamelen en automatisch pompen van afvalwater zonder fecaliën en afvalwater met fecaliën boven het terugstuwniveau

WŁAŚCIWOŚCI OGNIOWE	NPD
SZCZELNOŚĆ WODNA I POWIETRZNA	Pozytywne
- Szczelność wodna	Pozytywne
- Szczelność zapachowa	
SPRAWNOŚĆ DZIAŁANIA (SKUTECZNOŚĆ TŁOCZENIA)	
- Przyłącza rurowe	Pozytywne
- Wymiary minimalne przewodów wentylacyjnych	Pozytywne
- Minimalna prędkość przepływu	Pozytywne
- Minimalna, swobodna przepustowość instalacji	Pozytywne
- Minimalna objętość użytkownika	Pozytywne
WYTRZYMAŁOŚĆ MECHANICZNA	
- Nośność i stabilność konstrukcyjna zbiornika podczas stosowania poza budynkami	NPD
- Nośność i stabilność konstrukcyjna zbiornika podczas stosowania w budynkach	Pozytywne
POZIOM HŁAŚASU	70 dB(A)
TRWAŁOŚĆ I WYTRZYMAŁOŚĆ	
- stabilność konstrukcyjna	Pozytywne
- skuteczność tłoczenia	Pozytywne
- wytrzymałość mechaniczna	Pozytywne
SUBSTANCJE NIEBIEZPIECZNE	NPD

INFIAMMABILITÀ	NPD
IMPERMEABILITÀ, ERMETICITÀ ALL'ARIA	Superata
- Impermeabilità	Superata
- Ermeticità agli odori	
EFFICACIA (CAPACITÀ DI SOLLEVAMENTO)	
- Pompaggio di materiali solidi	Superata
- Collegamenti al tubo	Superata
- Misure minime delle linee di ventilazione	Superata
- Velocità di scorrimento minima	Superata
- Passaggio libero minimo dell'impianto	Superata
- Volume utile minimo	Superata
RESISTENZA MECCANICA	
- Capacità di carico e stabilità strutturale del serbatoio di raccolta per l'uso al di fuori degli edifici	NPD
- Stabilità strutturale del serbatoio di raccolta per l'uso all'interno degli edifici.	Superata
SOGLIA DI RUMOROSITÀ	70 dB(A)
DURE VOLEZZA	
- della stabilità strutturale	Superata
- della capacità di sollevamento	Superata
- della resistenza meccanica	Superata
SOSTANZE PERICOLOSE	NPD

BRANDGEDRAG	NPD
WATERDICHTHEID; LUCHTDICHTHEID	succesvol
- Waterdichtheid	succesvol
- Geurdichtheid	
RENDEMENT (POMPWERKING)	
- Transport van vaste stoffen	succesvol
- Buisaansluitingen	succesvol
- Minimum afmeting van verluchtingsleidingen	succesvol
- Minimum doorstromingssnelheid	succesvol
- Minimum vrije doorgang van de installatie	succesvol
- Minimum nuttig volume	succesvol
MECHANISCHE VASTHEID	
- Draagkracht en structurele stabiliteit van de verzamelcontainer voor het gebruik buiten gebouwen	NPD
- Structurele stabiliteit van de verzamelcontainer voor het gebruik binnenin gebouwen	succesvol
GELUIDSNIVEAU	70 dB(A)
DUURZAAMHEID	
- van de structurele stabiliteit	succesvol
- van de pompwerking	succesvol
- van de mechanische vastheid	succesvol
GEVAARLIJKE STOFFEN	NPD



0197

JUNG PUMPEN GmbH - Industriestr. 4-6 33803 Steinhagen, Germany
20
466.11.2021.10

EEN 12050-1:2001; 2015**Čerpací stanice odpadních vod s fekáliemi**

Compli 300 E (JP50076)	Compli 1025/4 BW (JP50102)
Compli 400 E (JP50081)	Compli 1025/2 BW (JP50103)
Compli 400 E (JP50082)	Compli 1035/2 BW (JP50104)
Compli 400 (JP50079)	Compli 108/2 ME (JP50088)
Compli 400 (JP50080)	Compli 108/2 M (JP50089)
Compli 510/4 BW (JP50091)	Compli 120/2 M (JP50090)
Compli 515/4 BW (JP50092)	Compli 508/2 ME (JP50096)
Compli 525/4 BW (JP50093)	Compli 508/2 M (JP50097)
Compli 525/2 BW (JP50094)	Compli 520/2 M (JP50098)
Compli 535/2 BW (JP50095)	Compli 1008/2 ME (JP50112)
Compli 1010/4 BWE (JP50099)	Compli 1008/2 M (JP50113)
Compli 1010/4 BW (JP50100)	Compli 1020/2 M (JP50114)
Compli 1015/4 BW (JP50101)	

Sběr a automatické čerpání odpadních vod bez fekálií a odpadních vod s fekáliemi nad úroveň zpětného vzduťi

CHOVÁNÍ PŘI POŽÁRU	NPD
VODOTĚSNOST, VZDUCHOTĚSNOST	
- Vodotěsnost	vyhovuje
- Pachová těsnost	vyhovuje
ÚČINNOST (ZDVIH)	
- Doprava pevných látek	vyhovuje
- Potrubní přípojky	vyhovuje
- Minimální rozměry větracího vedení	vyhovuje
- Minimální průtoková rychlost	vyhovuje
- Volný minimální prostup zařízení	vyhovuje
- Minimální užitiný objem	vyhovuje
MECHANICKÁ PEVNOST	
- Nosnost a strukturální stabilita sběrné nádrže pro použití mimo budovy	NPD
- Strukturální stabilita sběrné nádrže pro použití uvnitř budov	vyhovuje
HLUČNOST	70 dB(A)
STÁLOST	
- Strukturální stability	vyhovuje
- Zdvihu	vyhovuje
- Mechanické pevnosti	vyhovuje
NEBEZPEČNÉ SUBSTANCE	NPD



0197

JUNG PUMPEN GmbH - Industriestr. 4-6 33803 Steinhagen, Germany
20
466.11.2021.10

EN 12050-1:2001; 2015**Čerpací stanice odpadových vod s obsahom fekálních splašků**

Compli 300 E (JP50076)	Compli 1025/4 BW (JP50102)
Compli 400 E (JP50081)	Compli 1025/2 BW (JP50103)
Compli 400 E (JP50082)	Compli 1035/2 BW (JP50104)
Compli 400 (JP50079)	Compli 108/2 ME (JP50088)
Compli 400 (JP50080)	Compli 108/2 M (JP50089)
Compli 510/4 BW (JP50091)	Compli 120/2 M (JP50090)
Compli 515/4 BW (JP50092)	Compli 508/2 ME (JP50096)
Compli 525/4 BW (JP50093)	Compli 508/2 M (JP50097)
Compli 525/2 BW (JP50094)	Compli 520/2 M (JP50098)
Compli 535/2 BW (JP50095)	Compli 1008/2 ME (JP50112)
Compli 1010/4 BWE (JP50099)	Compli 1008/2 M (JP50113)
Compli 1010/4 BW (JP50100)	Compli 1020/2 M (JP50114)
Compli 1015/4 BW (JP50101)	

Zber a automatické čerpanie odpadových vod bez fekálních a odpadových vod s obsahom fekálních splašků prostřednictvím úrovně vzduťi

REAKCIA POČAS POŽIARU	NPD
VODOTĚSNOST, VZDUCHOTĚSNOST	
- vodotěsnost	v poriadku
- pachová bezpečnost	v poriadku
ÚČINNOST (ÚČINNOK SANIA)	
- doprava pevných částic	v poriadku
- potrubné pripojky	v poriadku
- minimálne rozmery vetracích vedení	v poriadku
- minimálna rýchlosť prítoku	v poriadku
- voľný minimálny príchod systému	v poriadku
- minimálny užitkový objem	v poriadku
MECHANICKÁ PEVNOST	
- nosnosť a štruktúrna stabilita zbernej nádrby pre používanie mimo budov	NPD
- štruktúrna stabilita zbernej nádrby pre používanie v rámci budov	v poriadku
HLADINA HLUKU	70 dB (A)
TRVANLIVOSŤ	
- štruktúrne stability	v poriadku
- vedľajších účinkov	v poriadku
- mechanické pevnosti	v poriadku
NEBEZPEČNÉ LÁTKY	NPD



0197

JUNG PUMPEN GmbH - Industriestr. 4-6 33803 Steinhagen, Germany
20
466.11.2021.10

EN 12050-1:2001; 2015**Fekáliartalmú szennyvízkek átemelői**

Compli 300 E (JP50076)	Compli 1025/4 BW (JP50102)
Compli 400 E (JP50081)	Compli 1025/2 BW (JP50103)
Compli 400 E (JP50082)	Compli 1035/2 BW (JP50104)
Compli 400 (JP50079)	Compli 108/2 ME (JP50088)
Compli 400 (JP50080)	Compli 108/2 M (JP50089)
Compli 510/4 BW (JP50091)	Compli 120/2 M (JP50090)
Compli 515/4 BW (JP50092)	Compli 508/2 ME (JP50096)
Compli 525/4 BW (JP50093)	Compli 508/2 M (JP50097)
Compli 525/2 BW (JP50094)	Compli 520/2 M (JP50098)
Compli 535/2 BW (JP50095)	Compli 1008/2 ME (JP50112)
Compli 1010/4 BWE (JP50099)	Compli 1008/2 M (JP50113)
Compli 1010/4 BW (JP50100)	Compli 1020/2 M (JP50114)
Compli 1015/4 BW (JP50101)	

Fekália mentes szennyvíz és fekália tartalmú szennyvíz gyűjtése és emelése a visszatörődási szint felett

VISELKEDÉS TŰZ ESETÉN	NPD
VIZÁLÓSÁG, LEGÁTERESZTÉS	
- Vizálóság	Megfelelt
- Szagmentesség	Megfelelt
HATÉKONYSÁG (EMELŐ HATÁS)	
- Szilárd anyagok szállítása	Megfelelt
- Csőcsatlakozások	Megfelelt
- A szellőzővezetékek minimális méretei	Megfelelt
- Az áramlás minimális sebessége	Megfelelt
- A berendezés szabad, minimális áteresztése	Megfelelt
- Minimális hasznos volumen	Megfelelt
MECHANIKAI SZILÁRDSÁG	
- A gyűjtőtartály terhelhetősége és strukturális stabilitása épületeken kívüli használatához	NPD
- A gyűjtőtartály strukturális stabilitása épületeken belüli használatához	Megfelelt
ZAJSZINT	70 dB(A)
TARTÓSSÁG	
- a strukturális stabilitás tartóssága	Megfelelt
- az emelőhatás tartóssága	Megfelelt
- a mechanikai szilárdság tartóssága	Megfelelt
VESZÉLYES ANYAGOK	NPD



0197

JUNG PUMPEN GmbH - Industriestr. 4-6 33803 Steinhagen, Germany
20
466.11.2021.10

EN 12050-1:2001; 2015
Stație de pompare ape uzate cu materii fecale

Compli 300 E (JP50076)	Compli 1025/4 BW (JP50102)
Compli 400 E (JP50081)	Compli 1025/2 BW (JP50103)
Compli 400 E (JP50082)	Compli 1035/2 BW (JP50104)
Compli 400 (JP50079)	Compli 108/2 ME (JP50088)
Compli 400 (JP50080)	Compli 108/2 M (JP50089)
Compli 510/4 BW (JP50091)	Compli 120/2 M (JP50090)
Compli 515/4 BW (JP50092)	Compli 508/2 ME (JP50096)
Compli 525/4 BW (JP50093)	Compli 508/2 M (JP50097)
Compli 525/2 BW (JP50094)	Compli 520/2 M (JP50098)
Compli 535/2 BW (JP50095)	Compli 1008/2 ME (JP50112)
Compli 1010/4 BWE (JP50099)	Compli 1008/2 M (JP50113)
Compli 1010/4 BW (JP50100)	Compli 1020/2 M (JP50114)
Compli 1015/4 BW (JP50101)	

Colectarea și pomparea automată de ape uzate fără materii fecale și ape uzate cu materii fecale deasupra nivelului maxim posibil al apelor uzate din sistemul de canalizare

COMPORTAMENTUL ÎN CAZ DE INCENDIU	NPD
IMPERMEABILITATE LA APĂ, ETANȘEITATE LA AER	
- Impermeabilitate la apă	Reușit
- Etanșeitate la mirosuri	Reușit
EFICACITATE (EFICIENȚĂ DE POMPARE)	
- Transportul de materiale solide	Reușit
- Racorduri țevă	Reușit
- Dimensiuni minime ale conductelor de ventilație	Reușit
- Viteza de curgere minimă	Reușit
- Trecerea minimă liberă a instalației	Reușit
- Capacitate utilizabilă minimă	Reușit
REZISTENȚA MECANICĂ	
- Capacitatea portantă și stabilitatea structurală a rezervorului colector pentru utilizarea în afara clădirilor	NPD
- Stabilitatea structurală a rezervorului colector pentru utilizarea în interiorul clădirilor	Reușit
NIVEL DE ZGOMOT	70 dB(A)
DURABILITATEA	
- Stabilitatea structurală	Reușit
- Eficiență de pompare	Reușit
- Rezistența mecanică	Reușit
SUBSTANȚE PERICULOASE	NPD

EU-Konformitätserklärung
EU-Prohlášení o shodě
EU-Overensstemmelseserklæring
EU-Declaration of Conformity
EU-Vaatumustenmukaisuusvakuutus

EU-Déclaration de Conformité
EU-Megfelelőségi nyilatkozat
EU-Dichiarazione di conformità
EU-Conformiteitsverklaring
EU-Deklaracja zgodności

EU-Declaração de Conformidade
EU-Declarație de conformitate
EU-Vyhlasenie o zhode
EU-Försäkran om överensstämmelse

DE - Richtlinien - Harmonisierte Normen
 CS - Směrnice - Harmonizované normy
 DA - Direktiv - Harmoniseret standard
 EN - Directives - Harmonised standards
 FI - Direktiivi - Yhdenmukaistettu standardi

FR - Directives - Normes harmonisées
 HU - Irányelve - Harmonizált szabványok
 IT - Direttive - Norme armonizzate
 NL - Richtlijnen - Geharmoniseerde normen
 PL - Dyrektywy - Normy zharmonizowane

PT - Directiva - Normas harmonizadas
 RO - Directivă - Norme coroborate
 SK - Smernice - Harmonizované normy
 SV - Direktiv - Harmoniserade normer

- **2006/42/EG (MD)** **EN 809:1998/AC:2010, EN ISO 12100:2010, EN 60335-1:2012/A13:2017**
- **2011/65/EU (RoHS)**
- **2014/30/EU (EMC)** **EN 55014-1:2017/A11:2020, EN 55014-2:1997/A2:2008, EN 61000-3-2:2014, EN 61000-3-3:2013**
- **2014/34/EU (ATEX)** **EN 1127-1:2019**

JUNG PUMPEN GmbH - Industriestr. 4-6 - 33803 Steinhagen - Germany - www.jung-pumpen.de

DE - Wir erklären in alleiniger Verantwortung, dass das Produkt den aufgeführten Richtlinien entspricht.
 CS - Prohlašujeme na svou výlučnou odpovědnost, že výrobek odpovídá jmenovaným směrnícím.
 DA - Vi erklærer under ansvar at produktet i overensstemmelse med de retningslinjer
 EN - We hereby declare, under our sole responsibility, that the product is in accordance with the specified Directives.
 FI - Me vakuutamme omalla vastuullamme, että tuote täyttää ohjeita.
 FR - Nous déclarons sous notre propre responsabilité que le produit répond aux directives.
 HU - Kizárólagos felelősségünk tudatában kijelentjük, hogy ez a termék megfelel az Európai Unió fentnevezett irányelveinek.
 IT - Noi dichiariamo sotto la nostra esclusiva responsabilità che il prodotto è conforme alle direttive citate
 NL - Wij verklaren geheel onder eigen verantwoordelijkheid dat het product voldoet aan de gestelde richtlijnen.
 PL - Z pełną odpowiedzialnością oświadczamy, że produkt odpowiada postanowieniom wymienionych dyrektyw.
 PT - Declaramos, sob nossa exclusiva responsabilidade, que o produto está em conformidade com as Diretivas especificadas.
 RO - Declaram pe proprie răspundere că produsul corespunde normelor prevăzute de directivele mai sus menționate.
 SK - Na výlučnú zodpovednosť vyhlasujeme, že výrobok spĺňa požiadavky uvedených smerníc.
 SV - Vi försäkrar att produkten på vårt ansvar är utförd enligt gällande riktlinjer.

Compli 300 E (JP50076)

Compli 400 E (JP50081)
Compli 400 E (JP50082)
Compli 400 (JP50079)
Compli 400 (JP50080)

Compli 510/4 BW (JP50091)
Compli 515/4 BW (JP50092)
Compli 525/4 BW (JP50093)
Compli 525/2 BW (JP50094)
Compli 535/2 BW (JP50095)

Compli 1010/4 BWE (JP50099)
Compli 1010/4 BW (JP50100)
Compli 1015/4 BW (JP50101)
Compli 1025/4 BW (JP50102)
Compli 1025/2 BW (JP50103)
Compli 1035/2 BW (JP50104)

Compli 108/2 ME (JP50088)
Compli 108/2 M (JP50089)
Compli 120/2 M (JP50090)

Compli 508/2 ME (JP50096)
Compli 508/2 M (JP50097)
Compli 520/2 M (JP50098)

Compli 1008/2 ME (JP50112)
Compli 1008/2 M (JP50114)
Compli 1020/2 M (JP50115)

DE-Weitere normative Dokumente CS-Jinými normativními dokumenty DA-Andre normative dokumenter EN-Other normative documents FI-Muiden normien FR-Autres documents normatifs HU-Egyéb szabályozó dokumentumokban leírtaknak IT-Altri documenti normativi NL-Verdere normatieve documenten PL-Innymi dokumentami normatywnymi PT-Outros documentos normativos RO-Alte acte normative SK-Iným závazným dokumentom SV-Vidare normerande dokument:
EN 50274:2002/AC:2009,
EN 60335-2-41:2003/A2:2010,
TRBS 2153, CLC/TR 50404

DE-Bevollmächtigter für technische Dokumentation CS-Úprávněná osoba pro technickou dokumentaci DA-utoriseret person for teknisk dokumentation EN-Authorized person for technical documentation FI-Valtuutettu henkilö tekninen dokumentaatio FR-Personne autorisée à la documentation technique HU-Hivatalos személy műszaki dokumentáció IT-Persona abilitata per la documentazione tecnica NL-Bevoegd persoon voor technische documentatie PL-Pełnomocnik ds. dokumentacji technicznej PT-Pessoa autorizada para documentação técnica RO-Persoană autorizată pentru documentație tehnică SK-Úprávněná osoba pre technickú dokumentáciu SV-Auktoriserad person för teknisk dokumentation:

JUNG PUMPEN - Stefan Sirges - Industriestr. 4-6 - 33803 Steinhagen

Steinhagen, 20-11-2020

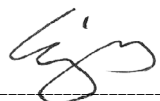
 Stefan Sirges, General Manager



 i.V. Pascal Köllkebeck, Sales Manager

Technische Daten - Technical data - Caractéristiques techniques- Technische Gegevens - Dati tecnici - Dane techniczne - Technické údaje - Technické údaje - Műszaki adatok - Date tehnice - 技术指标

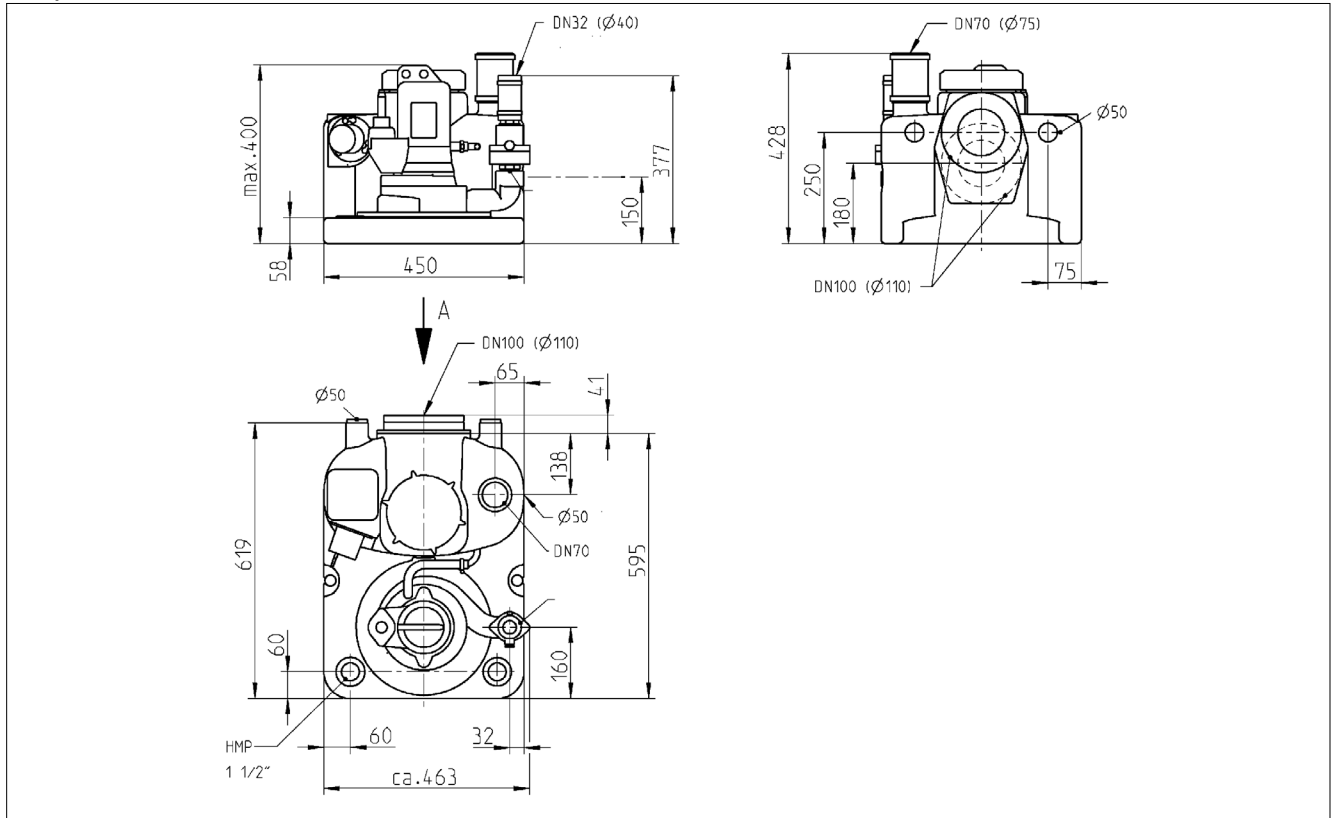
compli 100

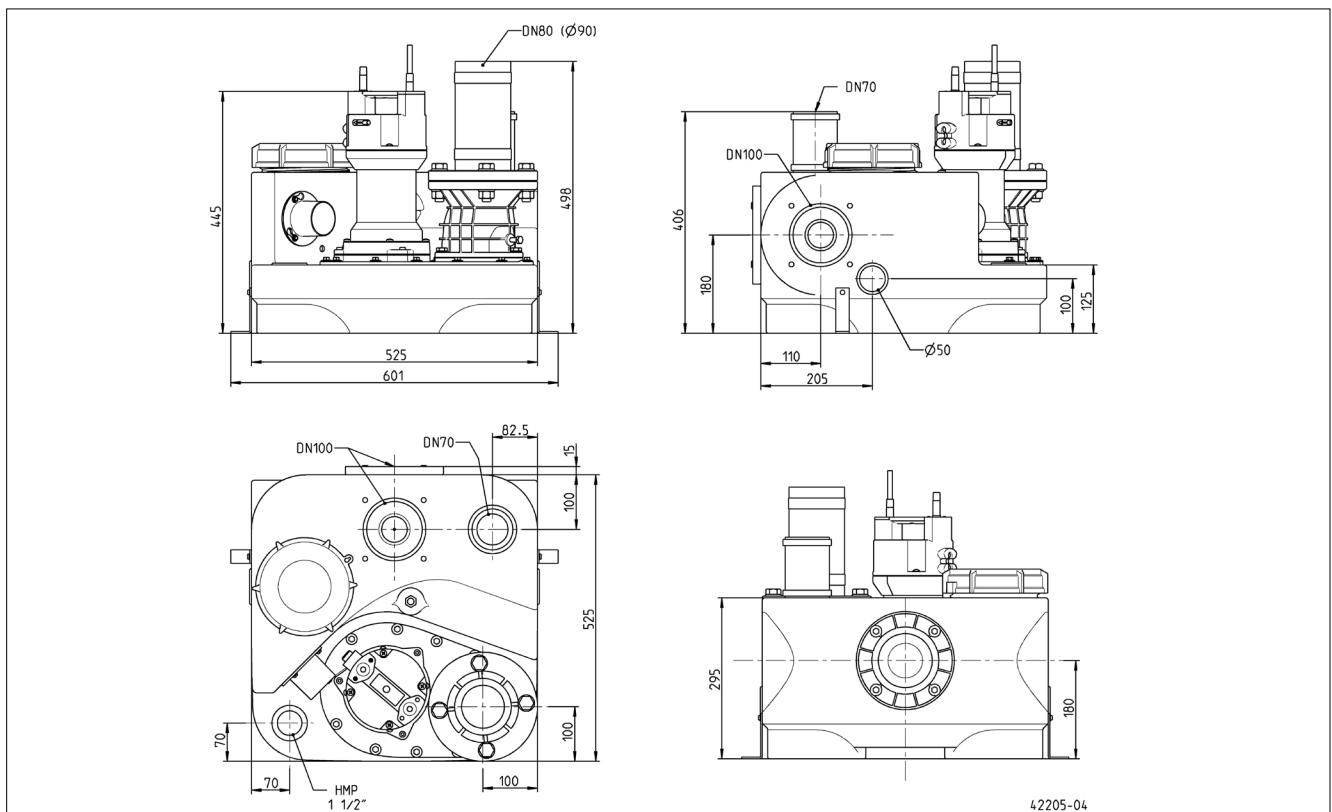

Compli 300



42205-04

compli 400

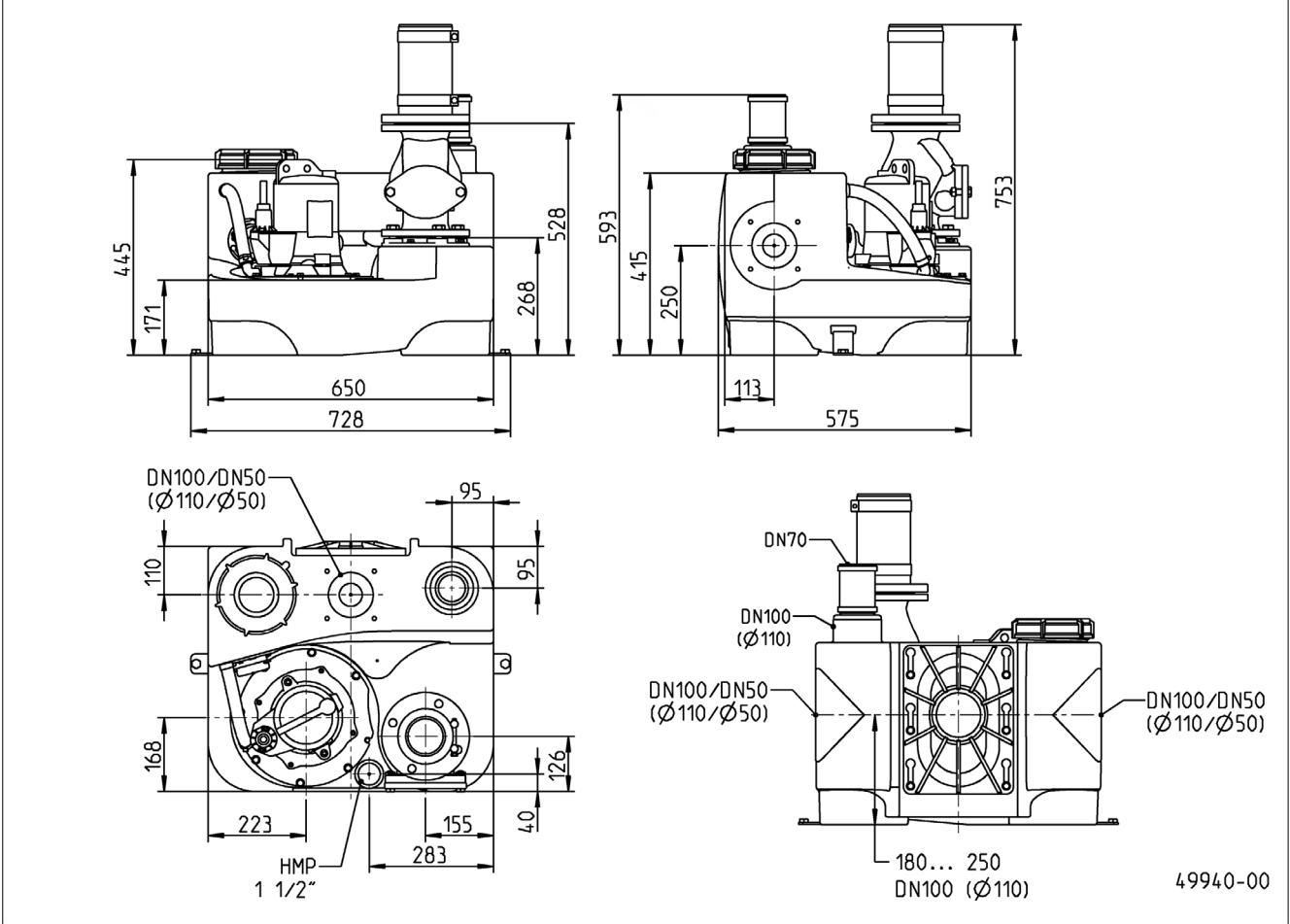

compli 500

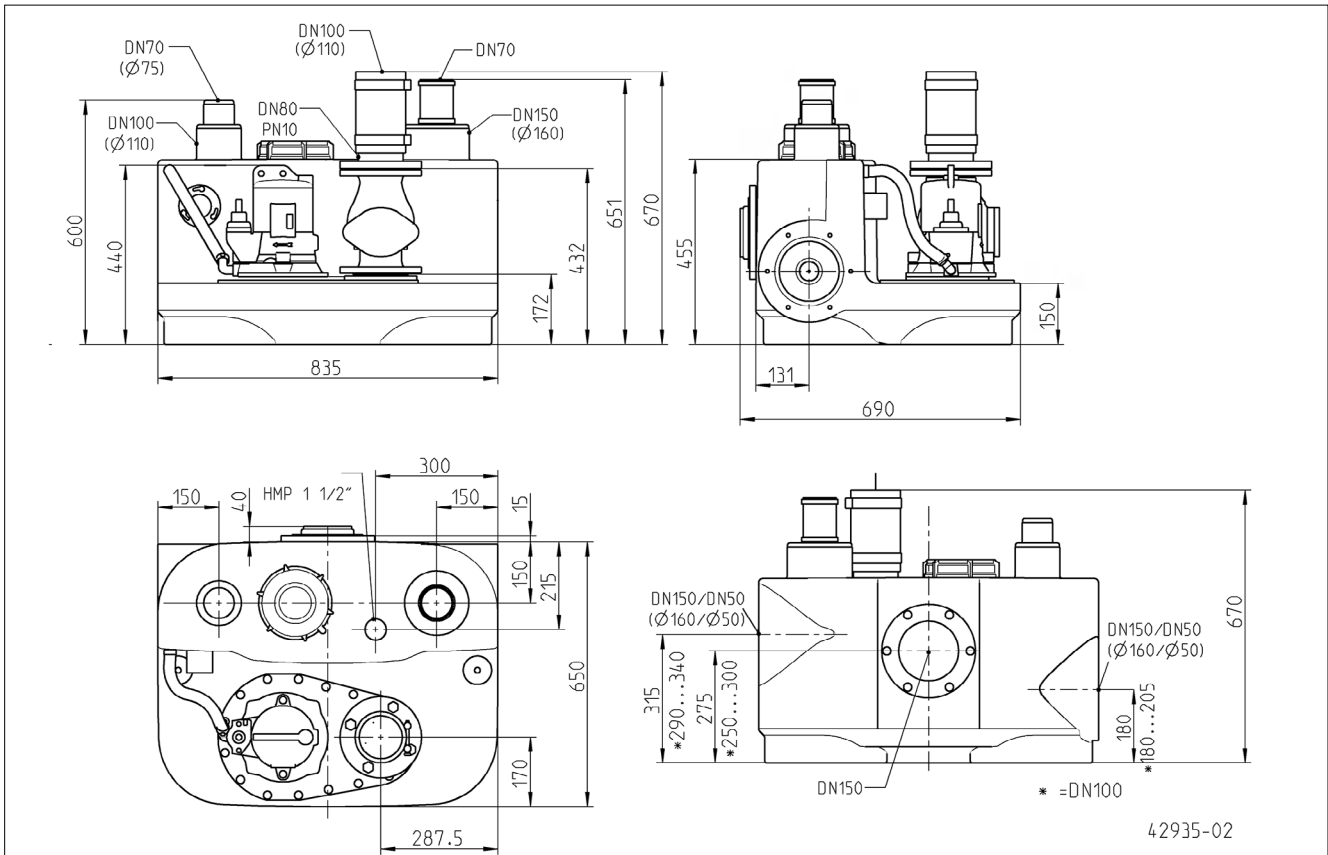

compli 500 M

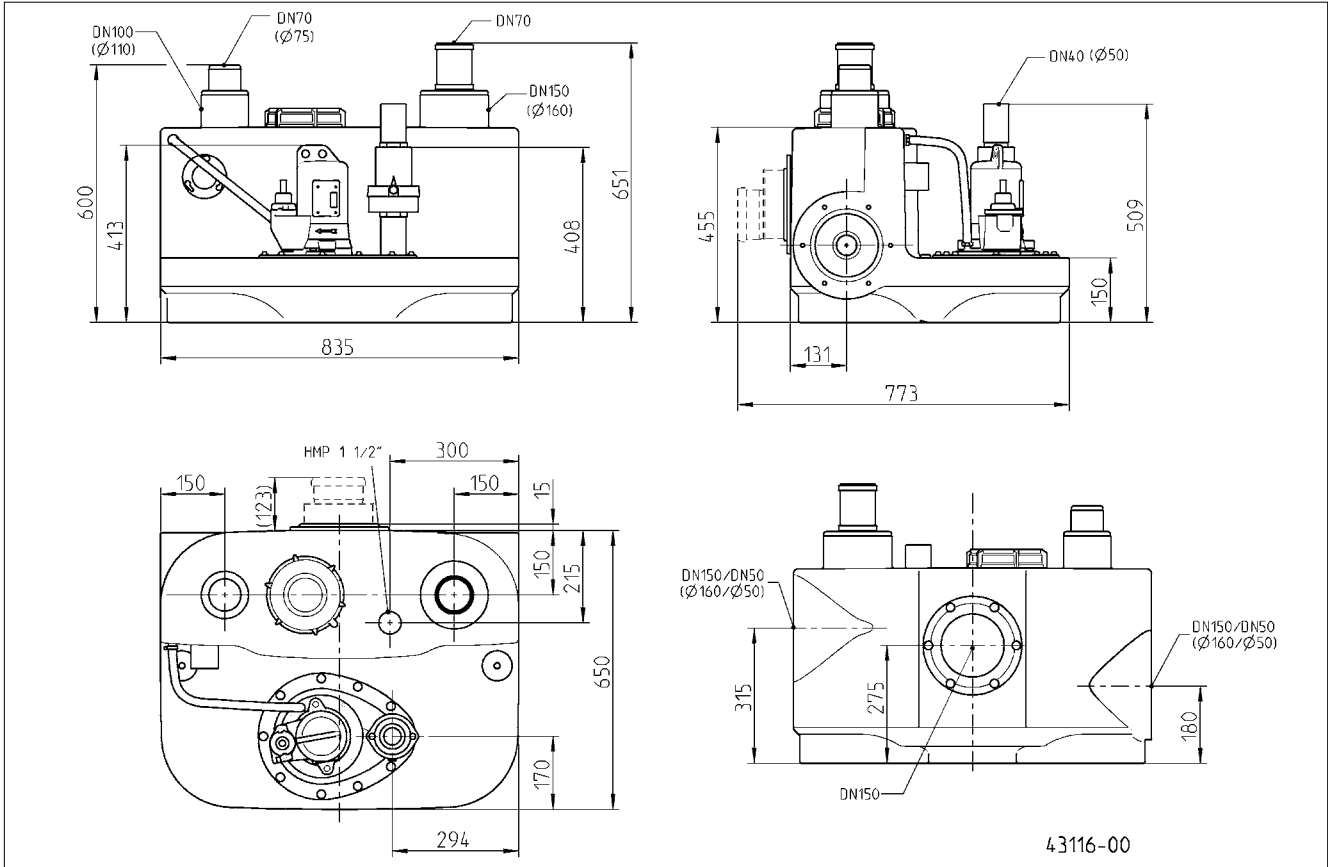

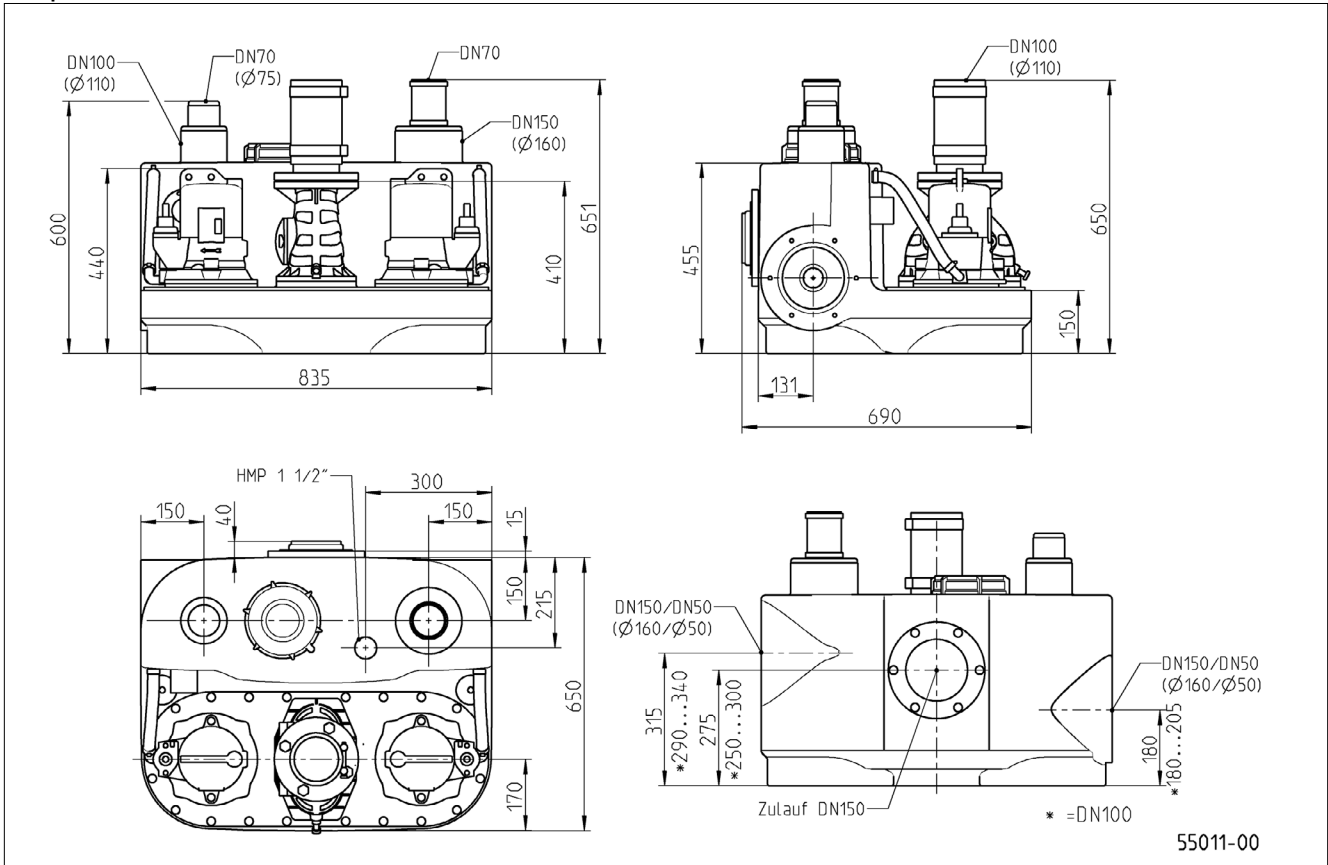

compli 1000

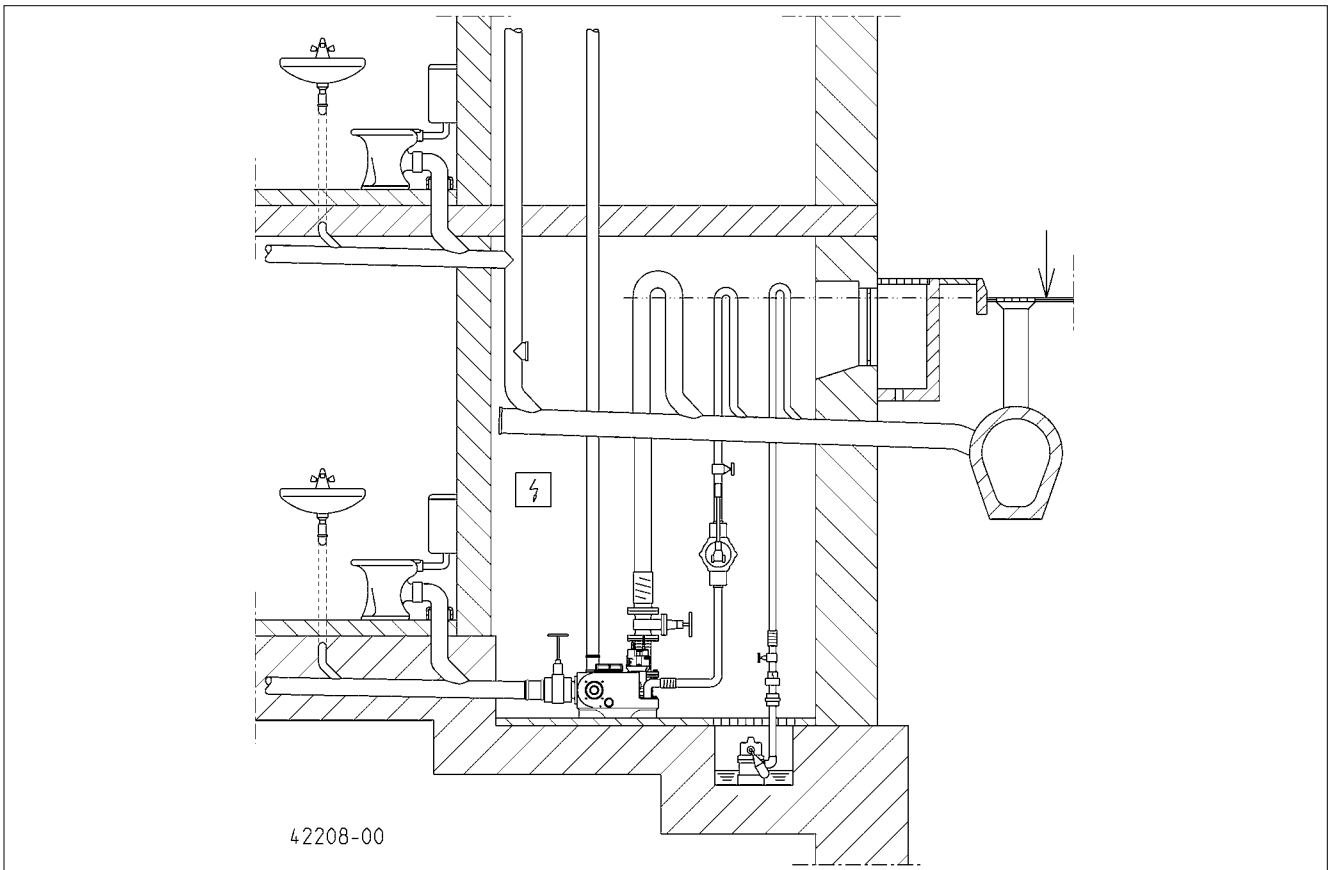
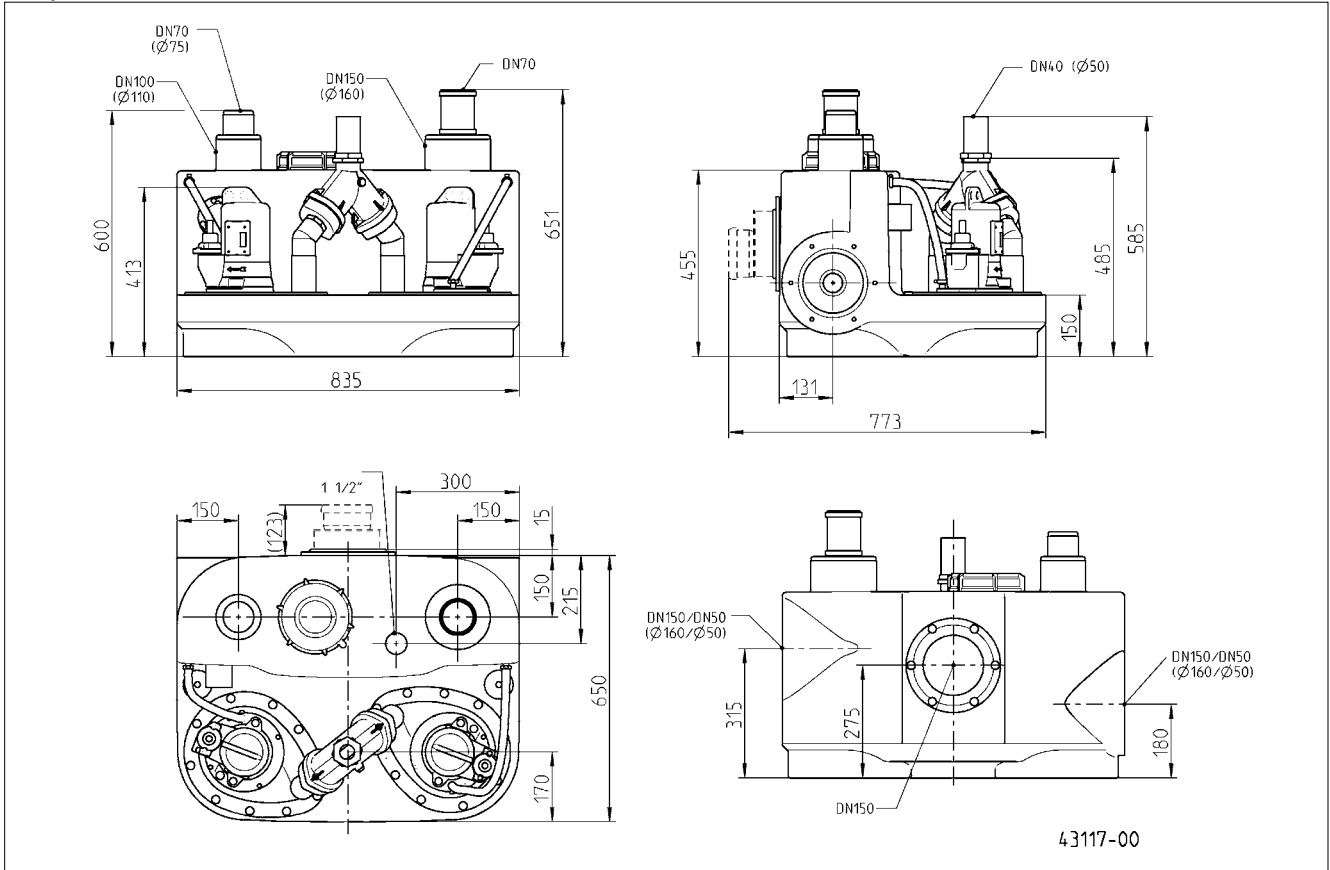

compli 1000 M



		... 300 E	... 400 E	... 1010 BWE	... 400
	[kg]	29	56	118	56
	PN 10	DN 80	DN 80	DN 80	DN 80
	[mm]	50	70	70	70
	S3*	10 %	25 %	25 %	30 %
P1	[kW]	1,37	1,55	1,55	1,25
P2	[kW]	0,98	1,10	1,10	0,87
U	[V]	1/N/PE ~230	1/N/PE ~230	1/N/PE ~230	3/N/PE ~400
f	[Hz]	50	50	50	50
I	[A]	6,0	7,1	7,1	2,2
n	[min ⁻¹]	2700	1428	1428	1390
			AD 69 ECR	BD 610 ECR	AD 00 R

		... 510/4 BW	... 515/4 BW	... 525/4 BW	... 425/2 BW	... 435/2 BW
		... 1010/4 BW	... 1015/4 BW	... 1025/4 BW	... 525/2 BW	... 535/2 BW
		... 1010/4 BW	... 1015/4 BW	... 1025/4 BW	... 1025/2 BW	... 1035/2 BW
	[kg]	79/128	79/128	79/128	81/86/125	84/89/132
	PN 10	DN 80	DN 80	DN 80	DN 80	DN 80
	[mm]	70	70	70	70	70
	S3*	45 %	30 %	15 %	25 %	25 %
P1	[kW]	1,3	2,2	3,0	3,3	4,8
P2	[kW]	1,0	1,7	2,2	2,6	4,0
U	[V]	3/N/PE ~400	3/N/PE ~400	3/N/PE ~400	3/N/PE ~400	3/N/PE ~400
f	[Hz]	50	50	50	50	50
I	[A]	2,8	3,9	5,1	5,4	7,8
n	[min ⁻¹]	1451	1405	1363	2807	2857
		AD 25 R / BD 25 R	AD 25 R / BD 25 R	AD 46 R / BD 46 R	AD 46 R / BD 46 R	AD 610 R / BD 610 R

		... 108/2 ME	... 108/2 M	... 120/2 M
		... 508/2 ME	... 508/2 M	... 520/2 M
		... 1008/2 ME	... 1008/2 M	... 1020/2 M
	[kg]	42/50/77	41/49/75	43/51/79
	PN 10	DN 32/40/40	DN 32/40/40	DN 32/40/40
	[mm]	7	7	7
	S3*	10 %	35 %	25 %
P1	[kW]	1,70	1,65	2,30
P2	[kW]	1,14	1,24	1,85
U	[V]	1/N/PE ~230	3/N/PE ~400	3/N/PE ~400
f	[Hz]	50	50	50
I	[A]	7,5	2,8	3,9
n	[min ⁻¹]	2584	2674	2860
		AD 08/2 MER	AD 00 R / BD 00 R	AD 46 R / BD 46 R

* Example for 40%: 4 min. operation and 6 min. rest (Cycle duration 10 min.);
 Esempio: 40%: 4 min. di funzionamento + 6 min. di pausa (durata del ciclo 10 min.)
 Příklad 40%: 4 min. provoz a 6 min. přestávka (trvání pracovního cyklu 10 min.)
 4 perc üzem és 6 perc szünet (ciklusidő 10 perc)

Exemple: 40% = 4 min de service et 6 min de pause (Durée du jeu 10 min)
 Przykładowo 40%: 4 min pracy i 6 min przerwy (Czas cyklu 10 min);
 Příklad 40%: 4 min prevádzka a 6 min prestávka (doba trvania cyklu 10 min);
 Exemplu 40%: 4 min funcționare și 6 min pauză (timp aproximativ 10 min)

Leistung - Performance - Puissances - Capaciteit - Prestazioni - Wydajności i moce -
 Výkony - Výkony - Teljesítmény - Capacități - 性能参数

H [m]	1	2	3	4	5	6	7	8	9	10	11	12	13	14	15	16	17
compli 300 E	30	29	28	24	22	19	15							Q [m³/h]			
compli 400 E	48	40	33	27	20	10											
compli 1010 BWE	48	40	33	27	20	10											
compli 400	48	40	33	27	20	10											
... 10/4 BW	48	40	33	27	20	10											
... 15/4 BW	69	62	56	49	42	36	27	19									
... 25/4 BW					56	49	42	32	22	13							
... 25/2 BW	69	64	58	52	47	42	37	33	28	23	20	14	8	1			
... 35/2 BW	85	80	75	71	66	62	57	54	50	47	44	39	36	33	30	26	21
... 08/2 ME		17		16		14		12		9		7		4			
... 08/2 M		17		16		14		12		9		7		4			
... 20/2 M								16		14		12		10			8

compli 300

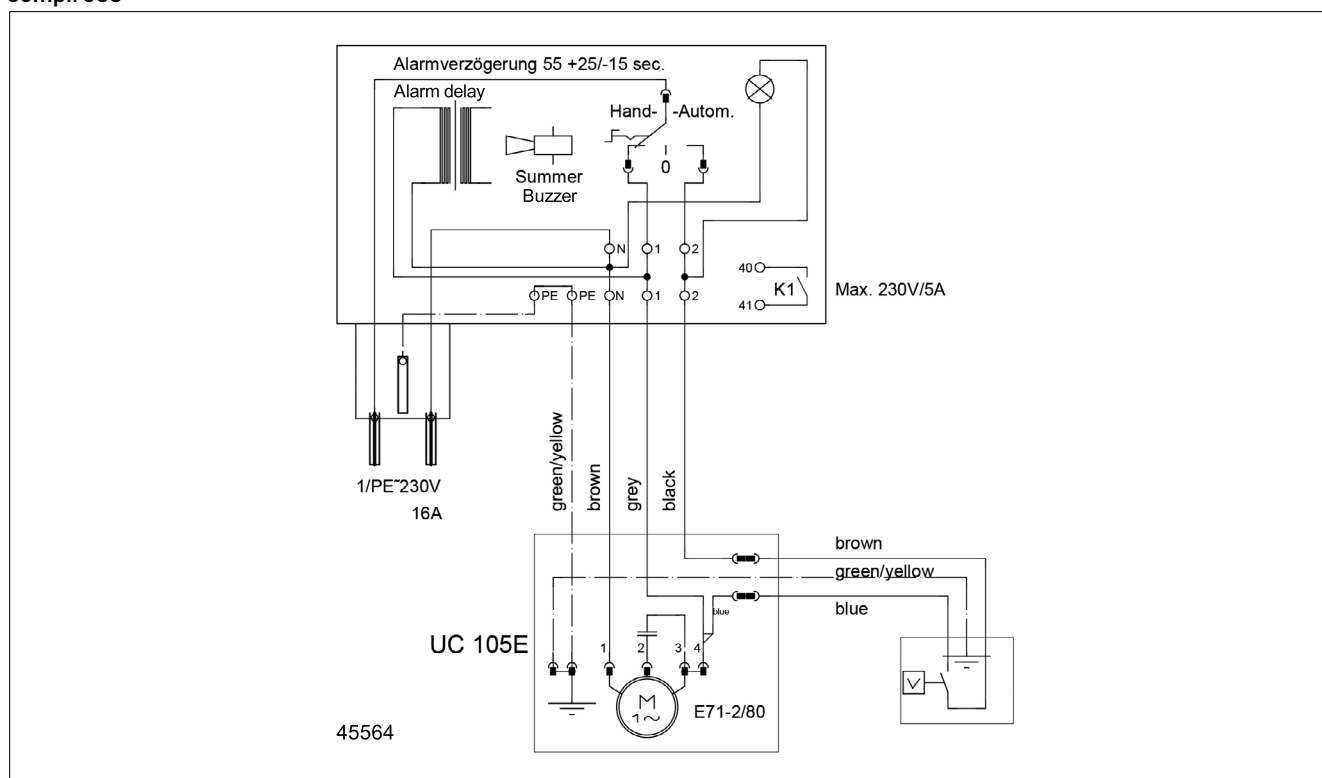

AD 69 ECR - Compli 400 E

Einzelanlage - Single unit - Unité de commande Poste simple - Regelaar van een enkelvoudige installatie - Comando singolo - Sterownik instalacji jednopompowej - Řídicí jednotka jednoduché zařízení - Riadenie samostatného zariadenia - Egyedi berendezés vezérlője - Sistem de comandă instalație individuală - 单泵系统

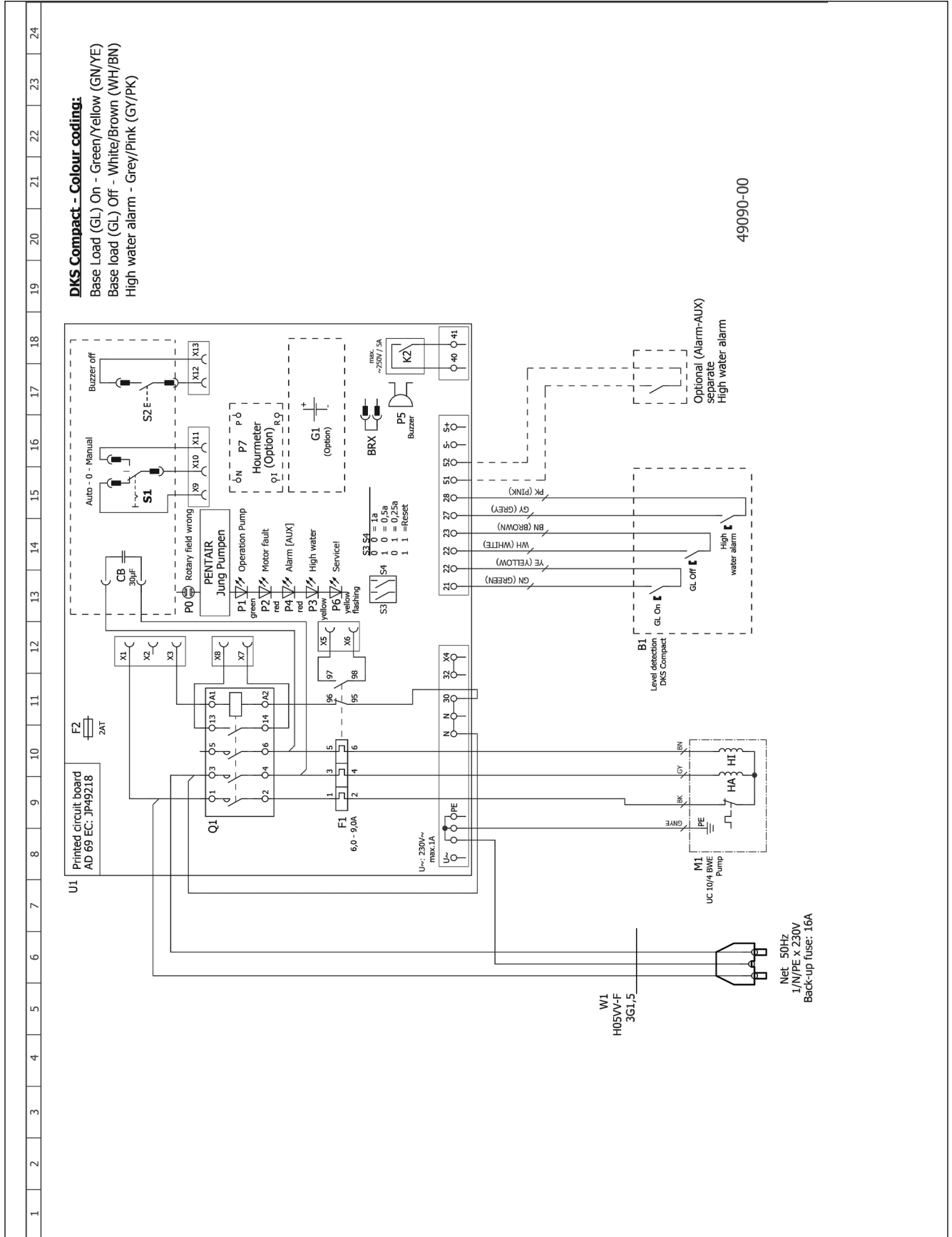

49090-00

Net: 50Hz
 1/N/PE x 230V
 Back-up fuse: 16A

AD 69 MECR - Compli 08/2

Einzelanlage - Single unit - Unité de commande Poste simple - Regelaar van een enkelvoudige installatie - Comando singolo -Stewownik instalacji jednopompowej - Řídicí jednotka jednoduché zařízení - Riadenie samostatného zariadenia - Egyedi berendezés vezérlője - Sistem de comandă instalație individuală - 单泵系统

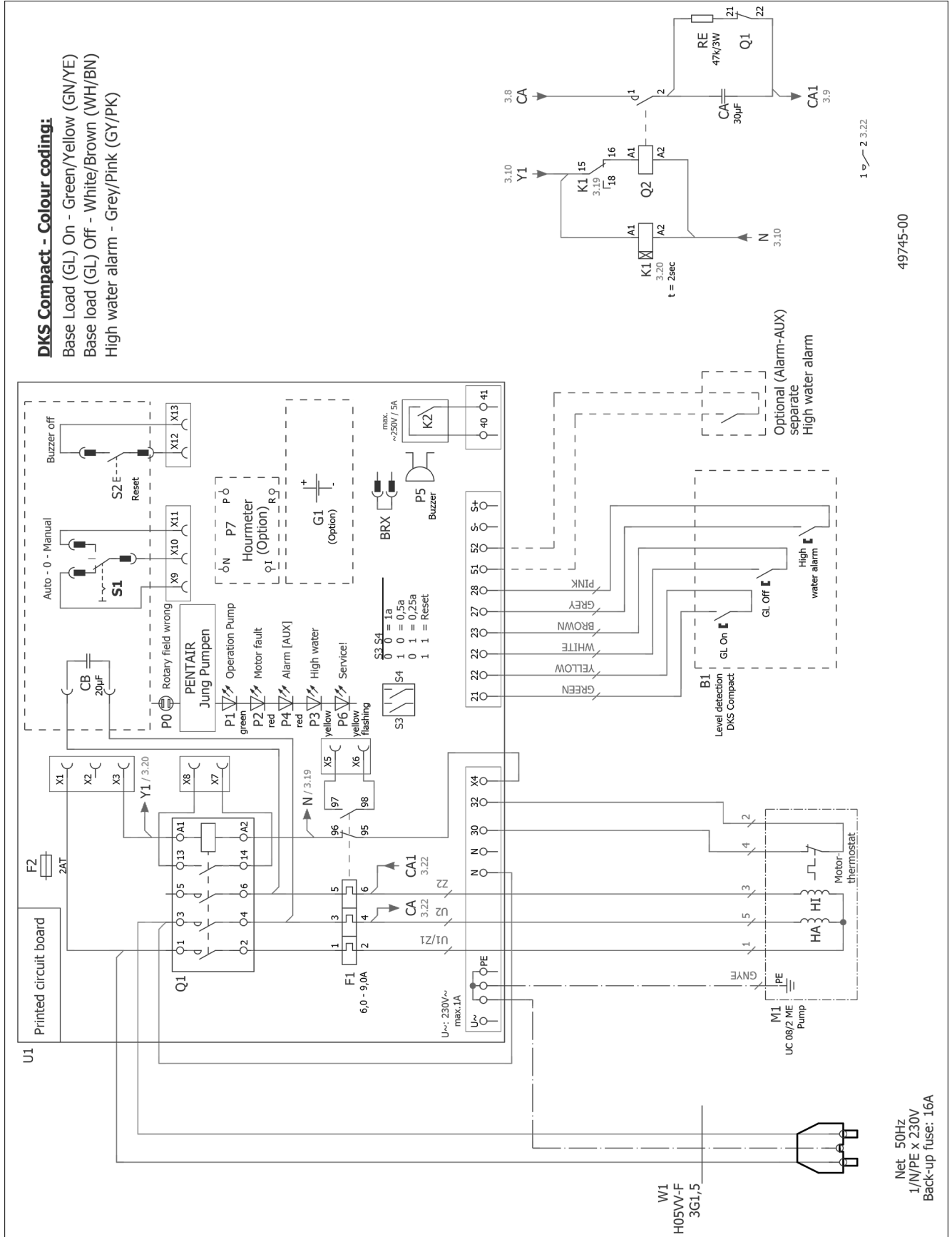

AD ... R

Einzelanlage - Single unit - Unité de commande Poste simple - Comando singolo - Regelaar van een enkelvoudige installatie
 - Sterownik instalacji jednopompowej - Řídicí jednotka jednoduché zařízení - Riadenie samostatného zariadenia - Egyedi berendezés vezérlője - Sistem de comandă instalație individuală - 单泵系统

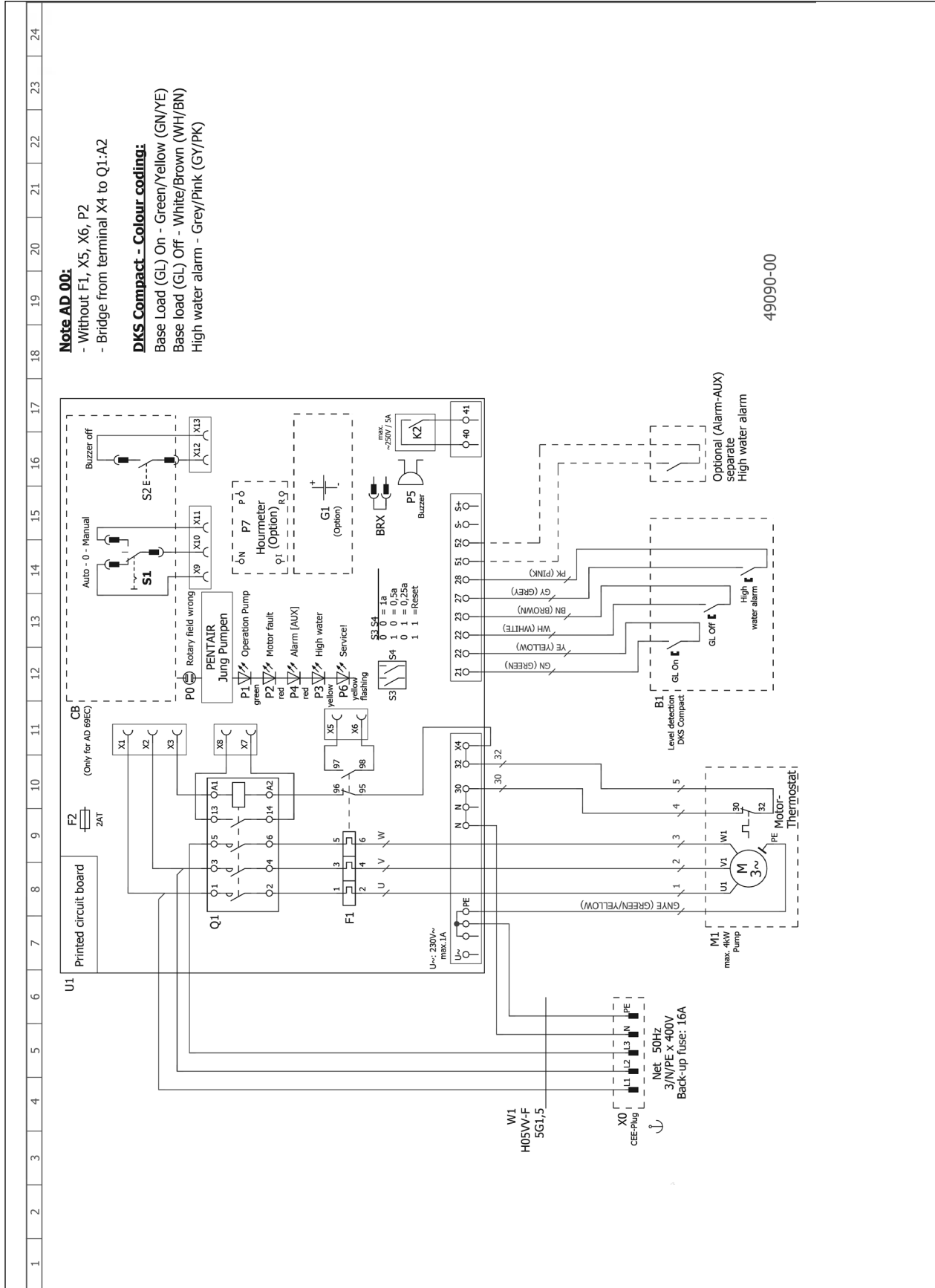

49090-00

BD 610 MECR - compli 1008/2 ME

Doppelanlage - Duplex unit - Comando doppio Unité de commande Poste double - Regelaar van een dubbele installatie - Comando doppio - Sterownik instalacji dwupompowej - Řídicí jednotka dvojité zařízení - Riadenie dvojitého zariadenia - Kettős berendezés - Sistem de comandă instalație dublă - 双泵系统

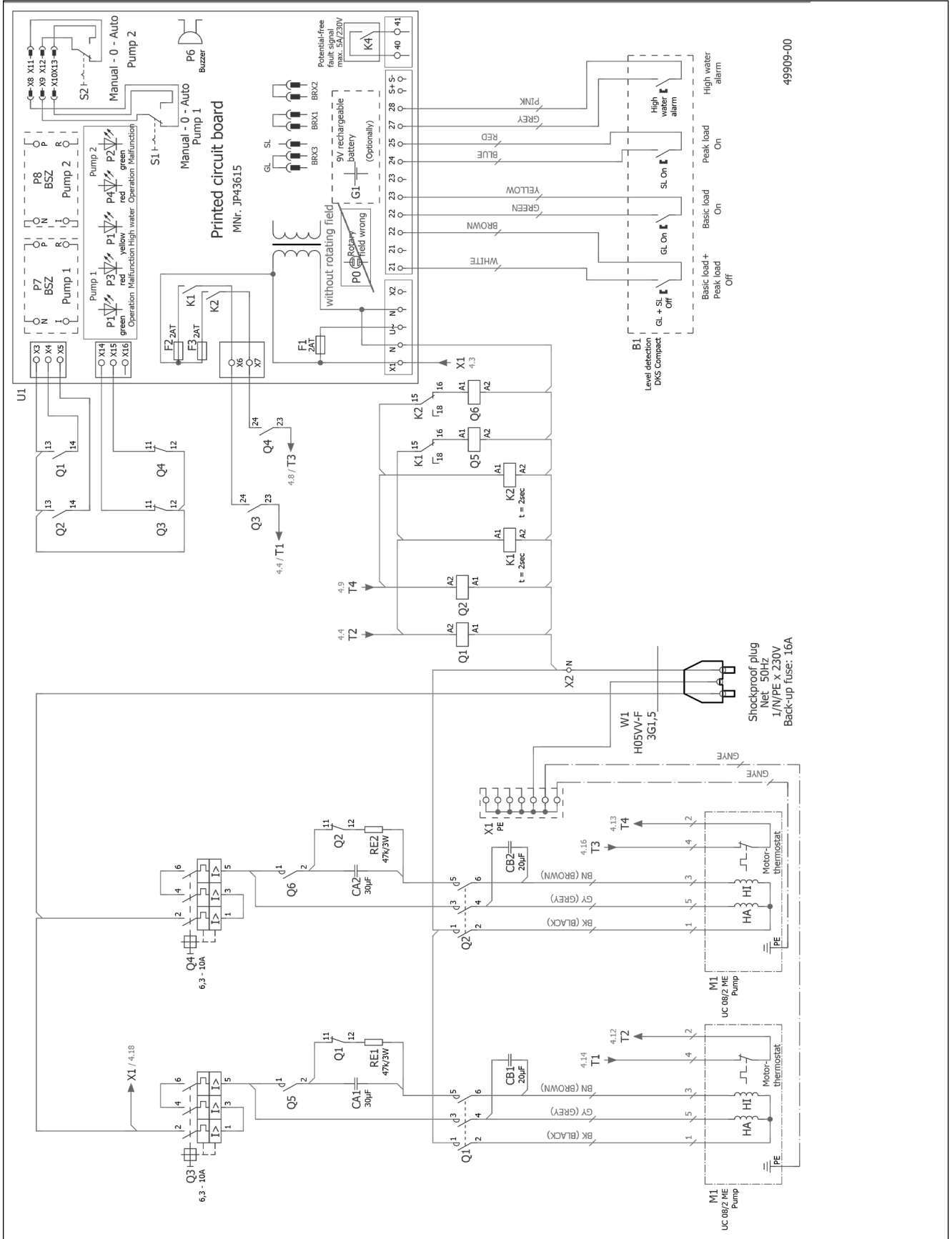

BD 610 ECR - Compli 1010/4 BWE

Doppelanlage - Duplex unit - Unité de commande Poste double - Comando doppio - Regelaar van een dubbele installatie - Sterownik instalacji dwupompowej - Řídicí jednotka dvojitě zařízení - Riadenie dvojitého zariadenia - Kettős berendezés - Sistem de comandă instalatie dublă - 双泵系统

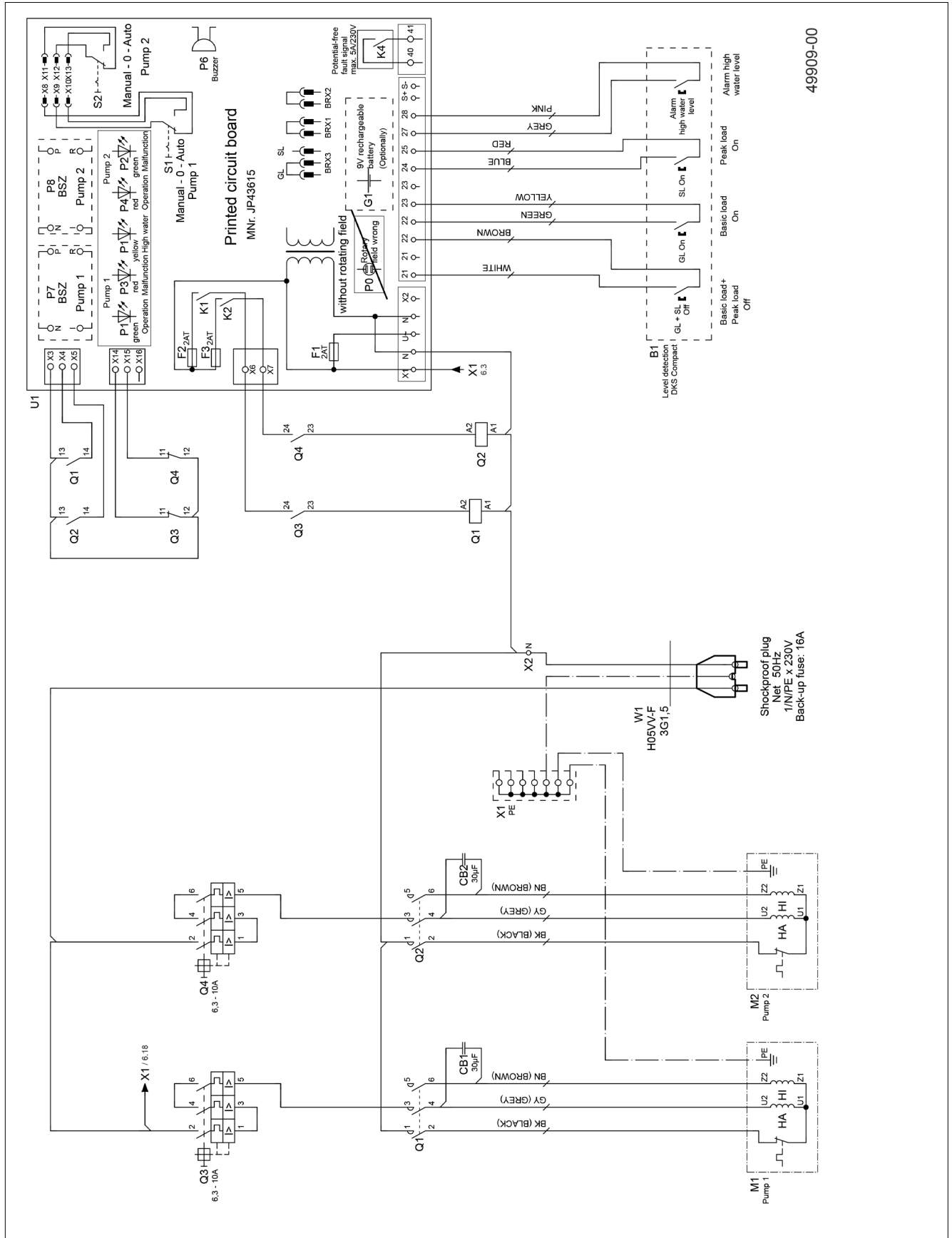

BD ... R

Doppelanlage - Duplex unit - Unité de commande Poste double - Comando doppio - Regelaar van een dubbele installatie - Sterownik instalacji dwupompowej - Řídicí jednotka dvojité zařízení - Riadenie dvojitého zariadenia - Kettős berendezés - Sistem de comandă instalatie dublă - 双泵系统

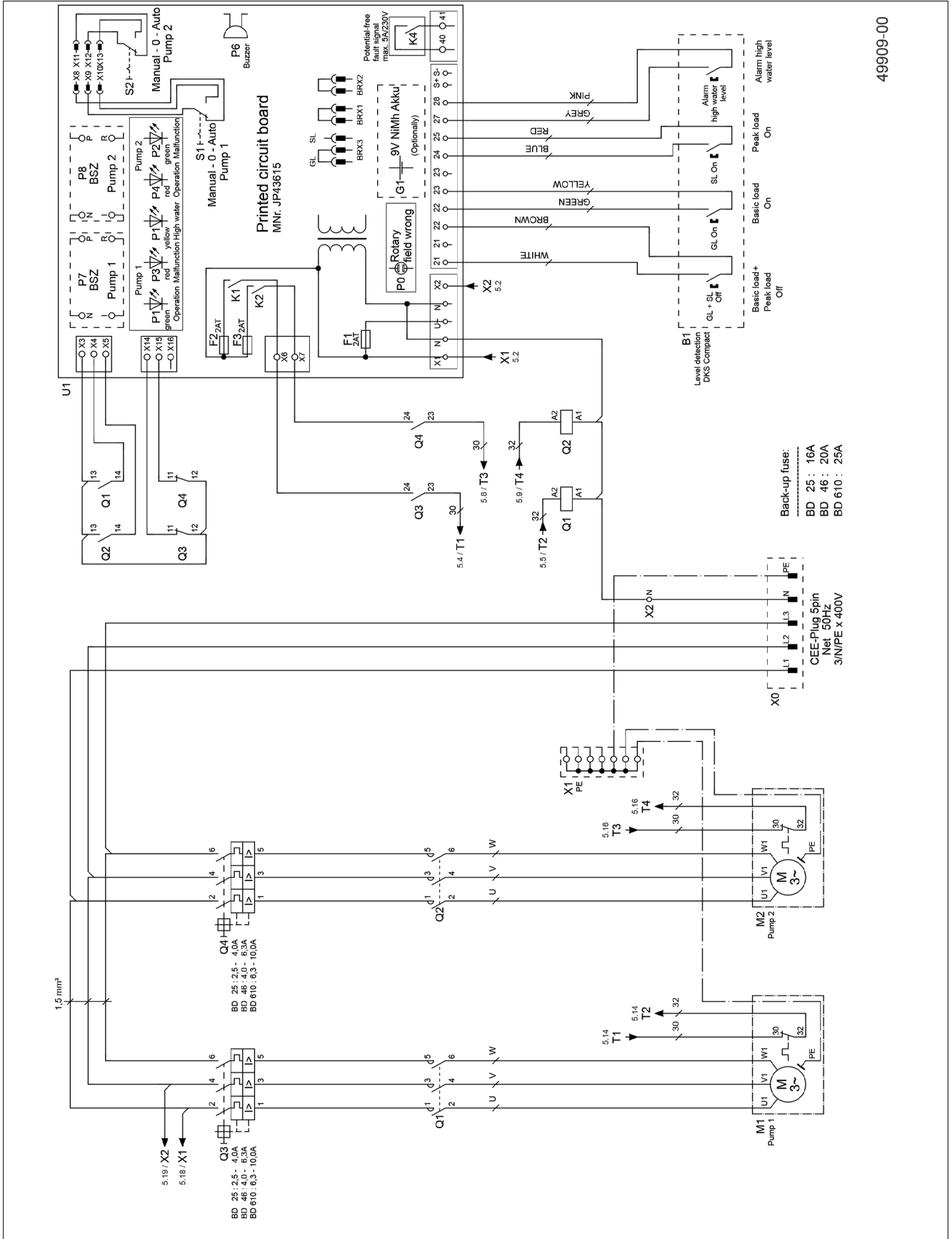

49909-00

Spare parts



①	Pumpe Compli 400 Compli 400 E	Pump	JP50469 JP50470
②	Adapter DN100/80		JP50478
③	Elast. Verbindung	Elastic connector	JP43705
④	Steuerung AD 00R (Compli 400) AD 69ECR (Compli 400 E)	Control unit	JP50491 JP50495
⑤	Pumpenaufnahme	Mounting ring pump	JP50477
⑥	Flansch	Flange	JP43706
⑦	Steuerungsplatine PCBA AD 00 (Compli 400) PCBA AD 69EC (Compli 400 E)	Control board	JP50497 JP50501
⑧	Niveauerfassung	Level control	JP50467
⑨	Rückschlagklappe	Reflux valve	JP43707
⑩	Zulauf	Inlet	JP50472
⑪	Montageset Pumpe	Pump assembly kit	JP49001
⑫	Dichtung Niveauerf.	Spare seal level control	JP50479
⑬	Wartungsdeckel	Service lid	JP42798
⑭	Montagering RSK	Mounting ring RV	JP50476
⑮	Dichtungen Drucks.	Seals discharge	JP50481
⑯	Dichtungen Hydr.	Seals hydraulic	JP50480
⑰	Überschiebmuffe	Collar	JP47287
⑱	Pumpenlüftung	Pump ventilation	JP43710
⑲	Steckdichtung	Plug in seal	JP45099
⑳	Auftriebssichg.	Anti floating	JP50473
㉑	Behälter (inkl. Pos 10)	Tank (incl. pos. 10)	JP50474

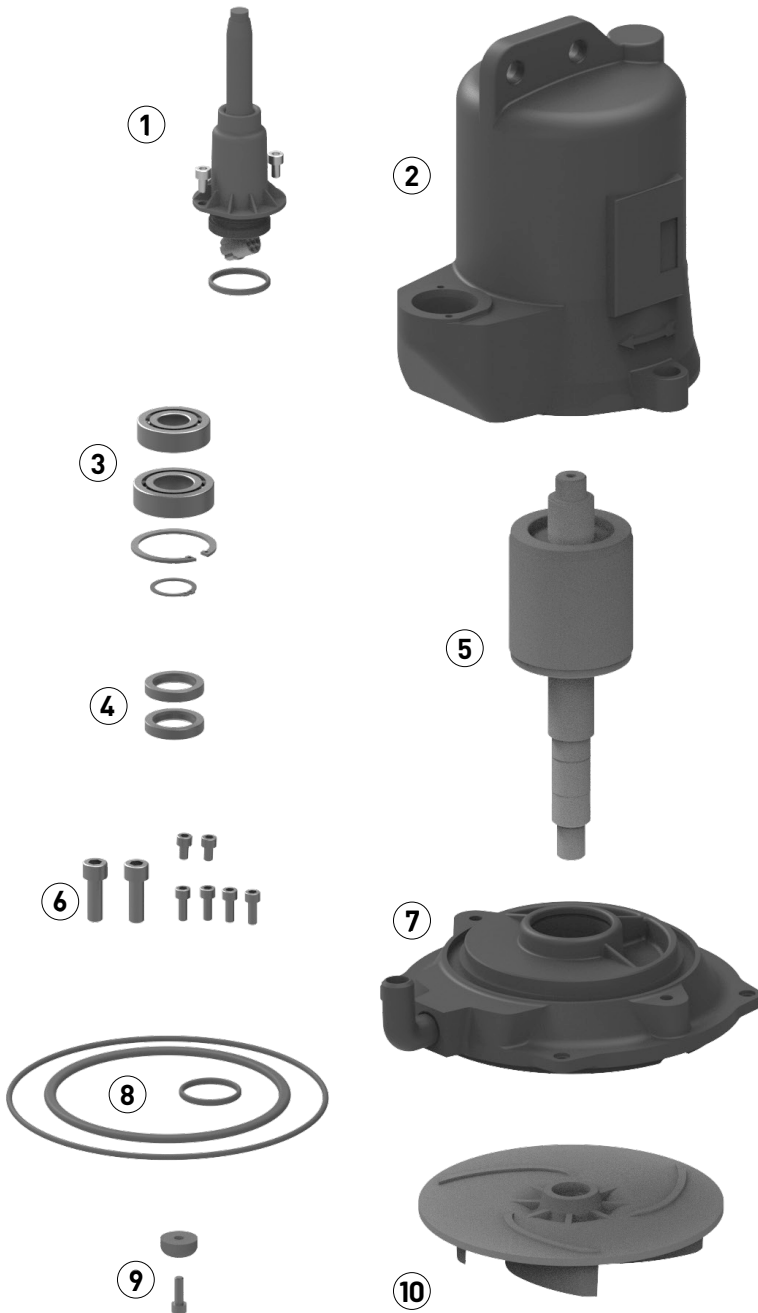

①	Leitung compli 400 compli 400 E	Cable 10/4 BW 10/4 BWE, 4m 10/4 BWE, 15m	JP50485 JP50486 JP50487
②	Stator + Gehäuse compli 400 compli 400 E	Stator + Housing	JP50488 JP50448
③	Lagersatz	Bearing set	JP46724
④	Motorabdichtung	Motor seals	JP46806
⑤	Rotorwelle compli 400 compli 400 E	Rotor shaft	JP46761 JP46801
⑥	Schraubensatz	Screw set	JP50450
⑦	Lagerschild	Bearing housing	JP43720
⑧	Dichtungssatz	Seal set	JP50449
⑨	Laufschraube	Impeller screw	JP46803
⑩	Laufwerk UC 10/4 UC 15/4 UC 25/4	Impeller	JP47290 JP50320 JP50321

Spare parts



①	Niveauerfassung	Level control	JP50467
②	Dichtung Niveauerfassung	Seal level control	JP50479
③	Adapter	Adapter	JP50478
④	Steuerung	Control unit	
	AD 25R (510/4, 515/4)		JP50492
	AD 46R (525/2, 525/4)		JP50493
	AD 610R (535/2)		JP50494
⑤	Elast. Verbindung	Elastic connector	JP43705
⑥	Flansch	Flange	JP43706
⑦	Steuerungsplatine	Control board	
	PCBA AD 25 (510/4, 515/4)		JP50498
	PCBA AD 46 (525/2, 525/4)		JP50499
	PCBA AD 610 (535/2)		JP50500
⑧	Pumpe	Pump	
	...10/4		JP50469
	...15/4		JP48824
	...25/4		JP48825
	...25/2		JP48826
	...35/2		JP48827
⑨	Rückschlagklappe	Reflux valve	JP43707
⑩	Reduzierstück DN 150/DN 100	Reducer DN 150/DN 100	JP48871
⑪	Basisplatte	Base plate	JP43711
⑫	Klemmflansch	Clamping flange	JP43713
⑬	Dichtband	Sealing tape	JP47966
⑭	Pumpenlüftung	Pump ventilation	JP43710
⑮	Wartungsdeckel	Service lid	JP42798
⑯	Steckdichtung D50xD59	Plug-in connection D50xD59	JP45099
⑰	Überschiebmuffe	Collar	JP47287
⑱	Auftriebssicherung	Anti floating	JP43709
⑲	Behälter	Tank	JP44860



COMPLI 500 M

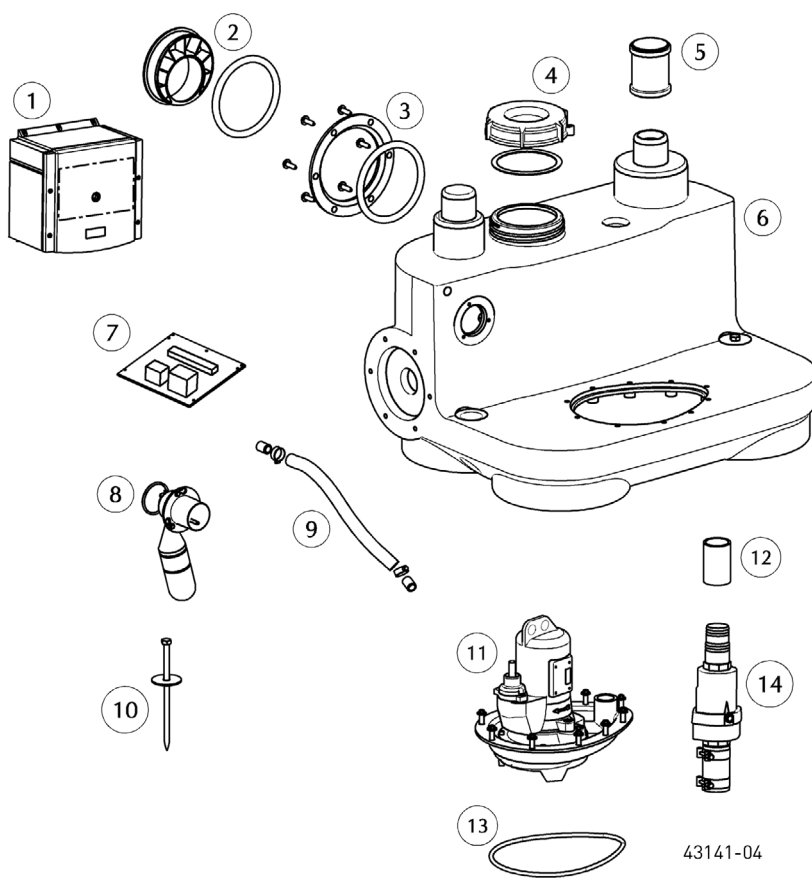

① Steuerung	Control unit	
08/2 ME		JP46825
08/2 M		JP46810
20/2 M		JP45789
② DN 150 / DN 100	DN 150 / DN 100	JP48871
③ Klemmflansch	Clamping flange	JP43713
④ Wartungsdeckel	Service lid	JP42798
⑤ Überschiebmuffe	Collar	JP47287
⑥ Behälter	Tank	JP46832
⑦ Steuerungsplatine	Control board	
08/2 ME		JP47693
08/2 M		JP46846
20/2 M		JP47717
⑧ Niveauerfassung	Level control	JP43712
⑨ Pumpenlüftung	Pump ventilation	JP43732
⑩ Auftriebssicherung	Anti floating	JP43709
⑪ Pumpe	Pump	
08/2 ME		JP46833
08/2 M		JP46834
20/2 M		JP46835
⑫ Elast. Verbindung	Elastic connector	JP43735
⑬ Rundschnur	Round cord	JP47967
⑭ Rückschlagklappe	Check valve	JP48138



① Niveauerfassung	Level control	
4 m		JP50467
15 m		JP50468
② Dichtung Niveauerfassung	Seal level control	JP50479
③ Adapter	Adaper	JP50478
④ Steuerung	Control unit	
BD 610ECR (1010/4 BWE)		JP50504
BD 25R (1010/4, 1015/4)		JP50505
BD 46R (1025/4, 1025/2)		JP50506
BD 610R (1035/2)		JP50507
⑤ Elastische Verbindung	Elastic connector	JP43705
⑥ Flansch	Flange	JP43706
⑦ Steuerungsplatine	Control board	JP47304
Leistungsschutz	Contactur	JP47671
230V DIL EM-10 4 KW	230V DIL EM-10 4 KW	
⑧ Pumpe	Pump	
...10/4 BWE, 4 m		JP50470
...10/4 BWE, 15 m		JP50584
...10/4		JP50469
...15/4		JP48824
...25/4		JP48825
...25/2		JP48826
...35/2		JP48827
⑨ Rückschlagklappe	Reflux valve	JP50566
⑩ Reduzierstück	Reducer	JP48871
DN 150/DN 100	DN 150/DN 100	
⑪ Doppelklappe	Double flap	JP46812
⑫ Klemmflansch	Clamping flange	JP43713
⑬ Basisplatte	Base plate	JP43714
⑭ Pumpenlüftung	Pump ventilation	JP43710
⑮ Dichtband	Sealing tape	JP47966
⑯ Wartungsdeckel	Service lid	JP42798
⑰ Steckdichtung	Plug-in connection	JP45099
D50xD59	D50xD59	
⑱ Überschiebmuffe	Collar	JP47287
⑲ Auftriebssicherung	Anti floating	JP43709
⑳ Behälter	Tank	JP44861

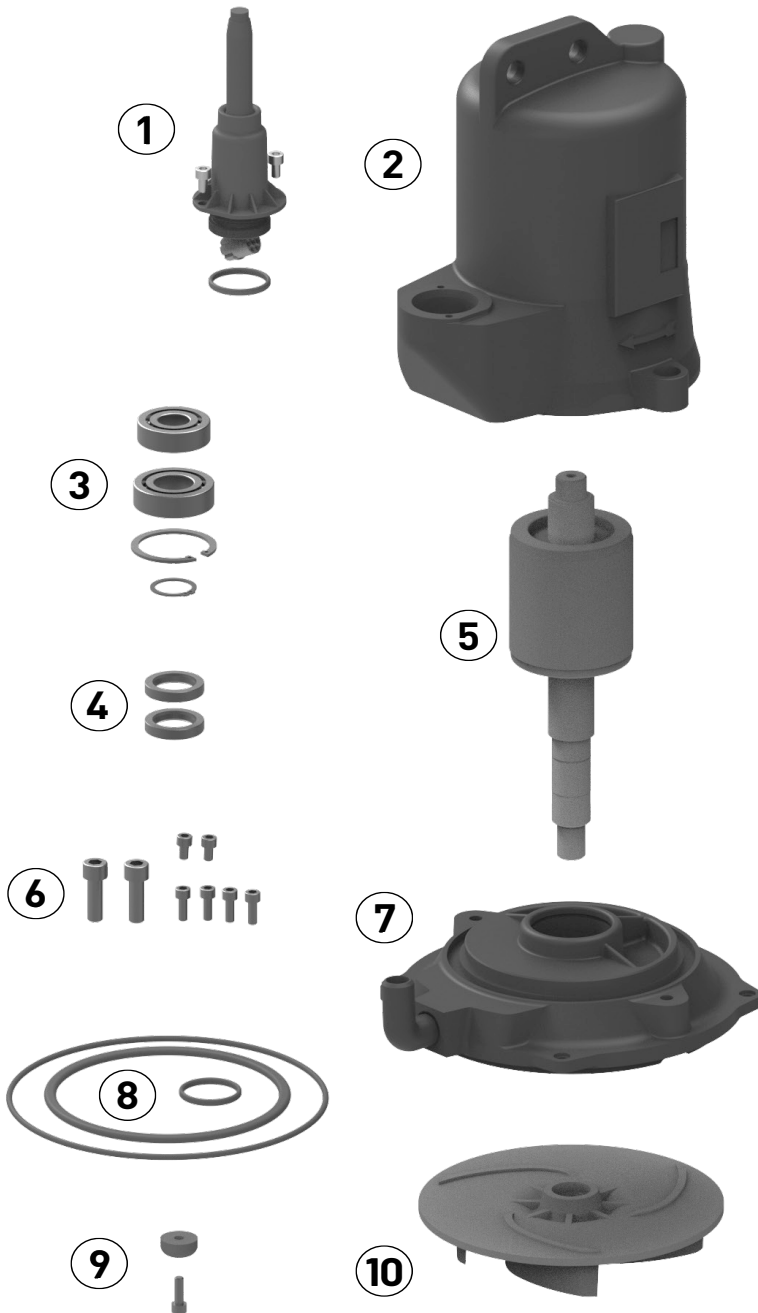

①	Leitung	Cable	
	10/4, 15/4, 25/4, 4 m		JP50485
	1010/4 BWE, 4 m		JP50486
	1010/4 BWE, 15 m		JP50487
②	Stator + Gehäuse	Stator + Housing	
	10/4		JP50488
	15/4, 25/4		JP50447
	1010/4 BWE		JP50448
③	Lagersatz	Bearing set	JP46724
④	Motorabdichtung	Motor seals	JP46806
⑤	Rotorwelle	Rotor shaft	
	10/4		JP46761
	15/4, 25/4		JP50322
	1010/4 BWE		JP46801
⑥	Schraubensatz	Screw set	JP50450
⑦	Lagerschild	Bearing housing	JP43720
⑧	Dichtungssatz	Seal set	JP50449
⑨	Lafradschraube	Impeller screw	JP46803
⑩	LaufRad	Impeller	
	10/4		JP47290
	15/4		JP50320
	25/4		JP50321
	1010/4 BWE		JP47290

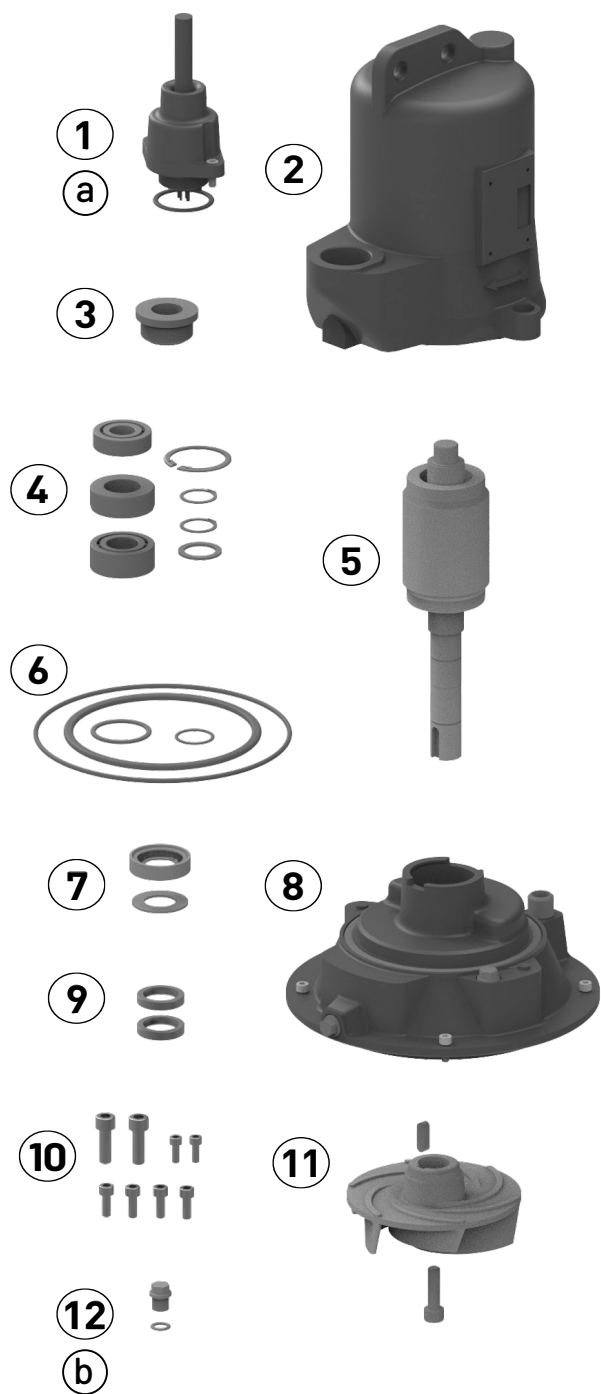

①	Leitung	Cable	JP43717
②	Stator + Gehäuse	Stator + Housing	
	25/2		JP44008
	35/2		JP46211
③	Gleitringdichtung	Mechanical seal	JP46567
④	Lagersatz	Bearing set	JP46214
⑤	Rotorwelle	Rotor shaft	
	25/2		JP48339
	35/2		JP48340
⑥	Dichtungssatz	Seal set	JP46807
⑦	Wellenabdeckung	Shaft cover	JP47043
⑧	Lagerschild	Bearing housing	JP43726
⑨	Motorabdichtung	Motor seals	JP46806
⑩	Schraubensatz	Screw set	JP47291
⑪	LaufRad	Impeller	
	25/2		JP48359
	35/2		JP48360
⑫	Ölschraube	Oil screw	JP46046

a	10x O-Ring 38x3,5	JP48109
b	10x O-Ring 10x2,5	JP48088



**PUMP TECHNICAL
SERVICES LIMITED**



Pump Technical Services Limited, Pump House, Unit 12 Bilton Road Industrial Estate, Erith, Kent, DA8 2AN. Tel: 01322 357 080 Website: www.pts-jung.co.uk Email: sales@pts-jung.co.uk