



PLANCOFIX LINE

EN Instruction Manual

You have purchased a product made by Pentair Jung Pumpen and with it, therefore, also excellent quality and service. Secure this service by carrying out the installation works in accordance with the instructions, so that our product can perform its task to your complete satisfaction. Please remember that damage caused by incorrect installation or handling will adversely affect the guarantee. Therefore please adhere to the instructions in this manual!

This appliance can be used by children aged 8 years or over and by persons with limited physical, sensory or intellectual capabilities, or with limited experience and knowledge, provided that they are supervised or have been instructed in the safe use of the appliance and are aware of the dangers involved. Children must not be allowed to play with the appliance. Cleaning and user maintenance must not be carried out by children unless they are supervised.

Damage prevention in case of failure

Like any other electrical device, this product may fail due to a lack of mains voltage or a technical defect.

If damage (including consequential damage) can occur as a result of product failure, the following precautions can be taken at your discretion:

- Installation of a water level dependent (under circumstances, mains-independent) alarm system, so that the alarm can be heard before damage occurs.
- Inspection of the collecting tank/chamber for tightness up to the top edge before – or at the latest, during – installation or operation of the product.
- Installation of backflow protection for drainage units that can be damaged by wastewater leakage upon product failure.
- Installation of a further product that can compensate in case of failure of the other product (e.g. duplex unit).
- Installation of an emergency power generator.

As these precautions serve to prevent or minimise consequential damage upon product failure, they are to be strictly observed as the manufacturer's guideline – in line with the standard DIN EN specifications as state of the art – when using the product (Higher Regional Court Frankfurt/Main, Ref.: 2 U 205/11, 06/15/2012).

SAFETY INSTRUCTIONS

This instruction manual contains essential information that must be observed during installation, operation and servicing. It is therefore important that the installer and the responsible technician/operator read this instruction manual before the equipment is installed and put into operation. The manual must always be available at the location where the pump or the plant is installed.

Failure to observe the safety instructions can lead to the loss of all indemnity.

In this instruction manual, safety information is distinctly labelled with particular symbols. Disregarding this information can be dangerous.



General danger to people



Warning of electrical voltage

NOTICE! Danger to equipment and operation

Qualification and training of personnel

All personnel involved with the operation, servicing, inspection and installation of the equipment must be suitably qualified for this work and must have studied the instruction manual in depth to ensure that they are sufficiently conversant with its contents. The supervision, competence and areas of responsibility of the personnel must be precisely regulated by the operator. If the personnel do not have the necessary skills, they must be instructed and trained accordingly.

Safety-conscious working

The safety instructions in this instruction manual, the existing national regulations regarding accident prevention, and any internal working, operating and safety regulations must be adhered to.

Safety instructions for the operator/user

All legal regulations, local directives and safety regulations must be adhered to.

The possibility of danger due to electrical energy must be prevented.

Leakages of dangerous (e.g. explosive, toxic, hot) substances must be discharged such that no danger to people or the environment occurs. Legal regulations must be observed.

Safety instructions for installation, inspection and maintenance works

As a basic principle, works may only be carried out to the equipment when it is shut down. Pumps or plant that convey harmful substances must be decontaminated.

All safety and protection components must be re-fitted and/or made operational immediately after the works have been completed. Their effectiveness must be checked before restarting, taking into account the current regulations and stipulations.

Unauthorised modifications, manufacture of spare parts

The equipment may only be modified or altered in agreement with the manufacturer. The use of original spare parts and accessories approved by the manufacturer is important for safety reasons. The use of other parts can result in liability for consequential damage being rescinded.

Unauthorised operating methods

The operational safety of the supplied equipment is only guaranteed if the equipment is used for its intended purpose. The limiting values given in the "Technical Data" section may not be exceeded under any circumstances.

Instructions regarding accident prevention

Before commencing servicing or maintenance works, cordon off the working area and check that the lifting gear is in perfect condition.

Never work alone. Always wear a hard hat, safety glasses and safety shoes and, if necessary, a suitable safety belt.

Before carrying out welding works or using electrical devices, check to ensure there is no danger of explosion.

People working in wastewater systems must be vaccinated against the pathogens that may be found there. For the sake of your health, be sure to pay meticulous Notice to cleanliness

wherever you are working.

Make sure that there are no toxic gases in the working area.

Observe the health and safety at work regulations and make sure that a first-aid kit is to hand.

In some cases, the pump and the pumping medium may be hot and could cause burns.

For installations in areas subject to explosion hazards, special regulations apply!

APPLICATION

Plancofix is a floor drainage pump that allows grey water to be pumped out of a domestic walk-in shower if a gravity sewer system is not available. The Plancofix is fitted directly under the shower.

The temperature of the shower water must not exceed 40°C.

The Plancofix must not be used as back-flow protection or for discharging other drainage units.

Use of the pumps is subject to relevant national laws, regulations and local requirements such as:

- Domestic contaminated water and waste water (e.g. EN 12056 in Europe)
- Installation of low voltage systems (e.g. VDE 0100 in Germany)

Further regulations must be observed (e.g. VDE 0100 in Germany, part 701: bathrooms and shower rooms)

Noise emission value < 70 dB(A)

ELECTRICAL CONNECTION

NOTICE! Electrical work on the Plancofix must be carried out by a qualified electrician only.



WARNING!

Before carrying out any work, disconnect the unit completely from the mains power supply (e.g. by unplugging it from the mains, or turning off the main switch, or triggering the FI circuit breaker) and ensure that the power supply to the unit cannot be switched on again by anyone else.

NOTICE! Never put the free end of the cable in water! If water gets into it, this can cause malfunctions and damage.

Current applicable standards (such as EN standards), national regulations (such as VDE in Germany), and the regulations of the local power supply companies must be complied with.

Observe the operating voltage (see type plate)! Only connect the pump to electrical circuits that have been installed properly in accordance with the regulations and are fitted with at least a 10 A (delay) fuse and an FI circuit breaker (30 mA).

The pump is provided with a winding thermostat. In case of unacceptably high temperatures, it switches off the pump to protect it against possible damage. Unacceptably high temperatures may result, for example, from dry running, or mechanical or electrical overload.

INSTALLATION

NOTICE! Make sure that the existing concrete floor is sufficiently thick and that the structural conditions allow a recess to be made.

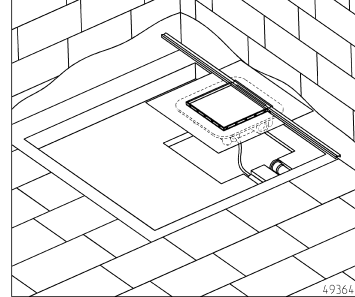

The Plancofix is recessed entirely into the floor. The unit can be accessed for maintenance through the top cover.

A sufficiently deep 40 x 40 cm recess must be created for the tank, but it must not be larger than the sealing fleece.

The shower channel can be adjusted in length (shortened outside) on site.

In order to achieve an incline of 2% towards the shower channel, Plancofix must not be installed flush, but recessed to a sufficient extent.

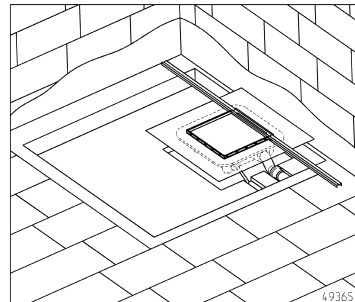

Conduits must be created for the pressure pipe and electricity supply cable, 1" FPT pressure pipe outlet, 3/4" cable conduit.

Inserting the tank

NOTICE! The protective covers at the side and the top must be fitted to the Plancofix.

1. Screw on the four feet.
2. Adjust the feet until the Plancofix is level and is standing in the recess at the appropriate height.
3. To reduce the transmission of sounds to a minimum, the protective cover at the side of the tank must remain in place.
4. **Notice!** The following materials are approved for the pressure pipe: PVC (DIN 8062), PE-HD (DIN 8074) and PP (DIN 8077).
Notice! When the pressure pipe is connected to the pressure outlet, do not seal the connection with hemp but wind not more than 6 layers of Teflon tape around the outlet. Acoustically isolate the pressure pipe, connect it to the pressure outlet with a 1" female thread and route it to the nearest downpipe.
Notice! Tighten the fitting carefully to avoid damaging the pressure outlet.
5. If the pressure pipe is laid horizontally, the hand-over point to the downpipe must lie 25 cm higher than the Plancofix.

In the highest point, the pressure pipe must be extended to avoid a suction lifter.

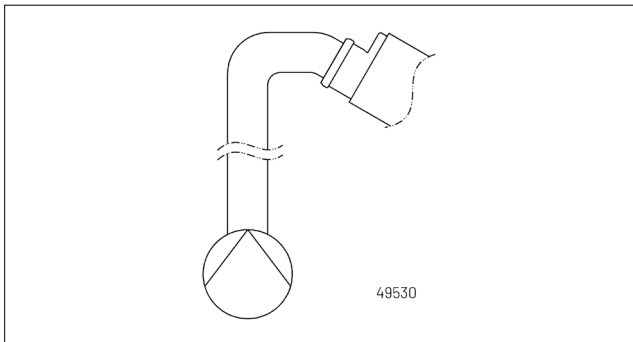
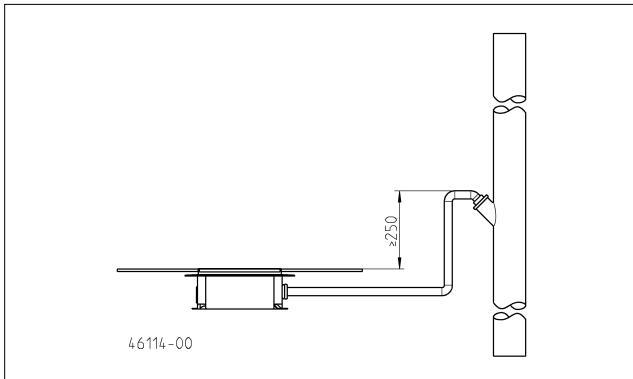

Test run

Motor noises on starting up are not a cause for concern as they are normal in synchronous motors.

NOTICE! Carry out a trial run before laying the screed.

Fill water in from above through the floor drain and get the Plancofix to pump out several times. The full water capacity must be pumped!

Look for any leaks around the inlet and the pressure pipe. Later changes can only be made with a considerable effort.

Laying the screed

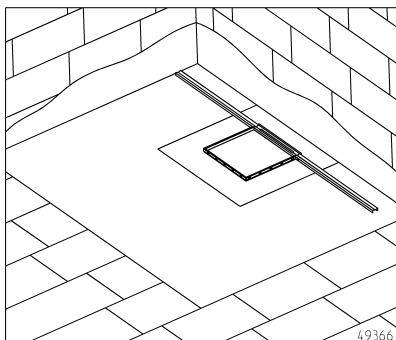

NOTICE! Prior to filling, fold the sealing fleece upwards and place a weight on it.

Plancofix must be weighted to ensure proper positioning during filling.

The entire area can now be filled with screed.

After the screed has set, the enclosed square seal is bonded to the integrated sealing strip. After the customer has attached a further thin-bed waterproofing system, the area can be tiled.

Secondary drainage

Secondary drainage can be provided by drilling holes (Ø 5mm) all round the edge above the sealing membrane.

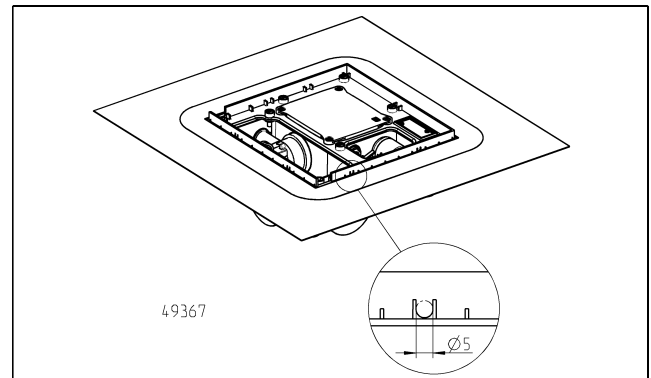

Tiling

NOTICE! We recommend a slope of 2%.

After setting and drying of the screed, the sealing fleece can be unfolded and the moisture seal can be provided.

Information on sealants and adhesives can be found in the information sheet on "Composite sealing" issued by the professional association of the German tile industry within the German Construction Confederation (ZDB).

Before tiling, the protective cover (plastic) must be removed and the decorative rails, channel and grating must be installed.

Differences in height between individual tiles can be offset by adjusting the plastic screws under the lid element.

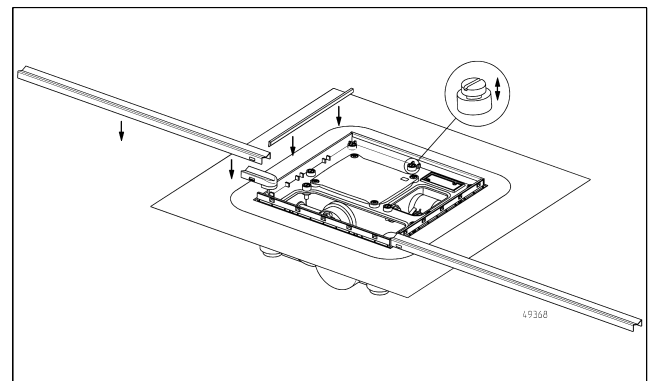

Notice! Do not seal the inner side of the gap that runs around the edge.

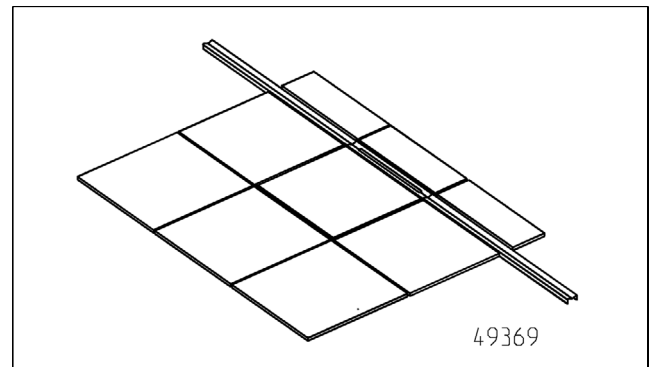

MAINTENANCE

WARNING!

Before carrying out any work, always disconnect the Plancofix from the power supply and ensure that it cannot be switched on again by other persons.

The system is largely maintenance-free. However, soap residues should be removed from the interior of the tank every 4 weeks. To do so, simply lift the cover off and then clean the inside carefully with a paintbrush.

The float may only be pulled up at the small nose up to the perceptible resistance!

NOTICE! Do not use aggressive drain cleaners!

If the hydraulic system is blocked, pull the red fixing element upwards and take it out. Next, gently loosen the hydraulic system and remove it. After cleaning, make sure that when you re-insert it, the swing-type check valve and the two seals are firmly in place. Finally, insert the red fixing element.

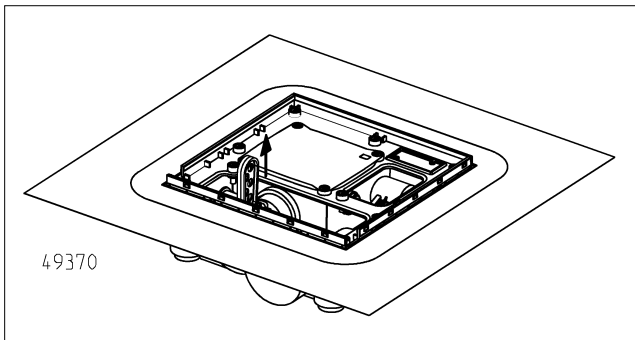

Technical Data

Plancofix line		
[kg]		4,4
DN		25
Schutzklasse / Protection class EN 61140		1
Schutzart / Ingress Protection EN 60529		IP 68
P1 [W]		30
U [V]		1/N/PE ~230
f [Hz]		50
I [A]		0,20
	[min ⁻¹]	3000
L _p [dB(A)]		56
S2		30 min
S3		30% *
H max [m]		1,3
Q max [l/min]		25

*
 (3/7 min Betrieb/Pause)
 (3/7 min operation/pause)
 (3/7 min service/interruption)
 (3/7 min bedrijf/pauze)
 (3/7 min funzionamento/pausa)
 (3/7 min praca / pauza)

Plancofix line

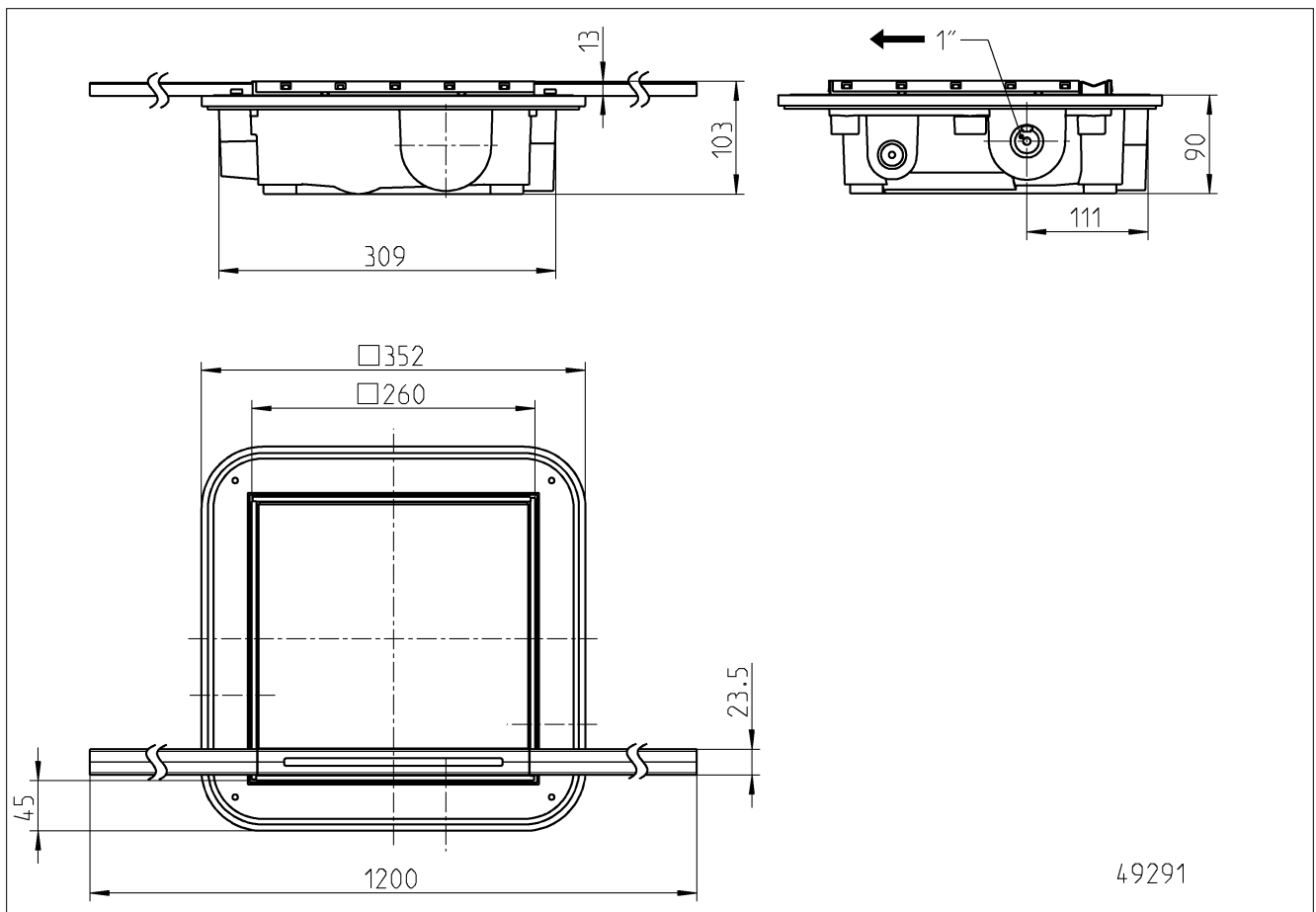

EU-Konformitätserklärung
EU-Prohlášení o shodě
EU-Overensstemmelseserklæring
EU-Declaration of Conformity
EU-Vaatumustenmukaisuusvakuutus

EU-Déclaration de Conformité
EU-Megfelelőségi nyilatkozat
EU-Dichiarazione di conformità
EU-Conformiteitsverklaring
EU-Deklaracja zgodności

EU-Declaratie de conformitate
EU-Vyhlášení o zhode
EU-Försäkran om överensstämmelse

DE - Richtlinien - Harmonisierte Normen
CS - Směrnice - Harmonizované normy
DA - Direktiv - Harmoniseret standard
EN - Directives - Harmonised standards
FI - Direktiivi - Yhdenmukaistettu standardi

FR - Directives - Normes harmonisées
HU - Irányelve - Harmonizált szabványok
IT - Direttive - Norme armonizzate
NL - Richtlijnen - Geharmoniseerde normen
PL - Dyrektywy - Normy zharmonizowane

RO - Directivă - Norme coroborate
SK - Smernice - Harmonizované normy
SV - Direktiv - Harmoniserade normer

- 2006/42/EG (MD)
- 2011/65/EU (RoHS)
- 2014/30/EU (EMC)

EN 809:1998/AC:2010; EN ISO 12100:2010, EN 60335-1:2012/A11:2014

EN 55014-1:2006/A2:2011, EN 55014-2:1997/A2:2008, EN 61000-3-2:2014, EN 61000-3-3:2013

JUNG PUMPEN GmbH - Industriestr. 4-6 - 33803 Steinhagen - Germany - www.jung-pumpen.de

DE - Wir erklären in alleiniger Verantwortung, dass das Produkt den aufgeführten Richtlinien entspricht.

CS - Prohlašujeme na svou výlučnou odpovědnost, že výrobek odpovídá jmenovaným směrnici.

DA - Vi erklærer under ansvar at produktet i overensstemmelse med de retningslinjer

EN - We hereby declare, under our sole responsibility, that the product is in accordance with the specified Directives.

FI - Me vakuutamme omalla vastuullamme, että tuote täyttää ohjeita.

FR - Nous déclarons sous notre propre responsabilité que le produit répond aux directives.

HU - Kizárólagos felelősségünk tudatában kijelentjük, hogy ez a termék megfelel az Európai Unió fentnevezett irányelveinek.

IT - Noi dichiariamo sotto la nostra esclusiva responsabilità che il prodotto è conforme alle direttive citate

NL - Wij verklaren geheel onder eigen verantwoordelijkheid dat het product voldoet aan de gestelde richtlijnen.

PL - Z pełną odpowiedzialnością oświadczamy, że produkt odpowiada postanowieniom wymienionych dyrektyw.

RO - Declarăm pe proprie răspundere că produsul corespunde normelor prevăzute de directivele mai sus menționate.

SK - Na výlučnú zodpovednosť vyhlasujeme, že výrobok spĺňa požiadavky uvedených smerníc.

SV - Vi försäkrar att produkten på vårt ansvar är utförd enligt gällande riktlinjer.

Plancofix (JP44685)

Plancofix plus (JP47014)

Plancofix line (JP50177)

DE - Weitere normative Dokumente CS - Jinými normativními dokumenty DA - Andre normative dokumenter EN - Other normative documents FI - Muiden normien FR - Autres documents normatifs HU - Egyéb szabályozó dokumentumokban leírtaknak IT - Altri documenti normativi NL - Verdere normative documenten PL - Innymi dokumentami normatywnymi RO - Alte acte normative SK - Iným záväzným dokumentom SV - Vidare normerande dokument:

EN 60335-2-41:2003/A2:2010



40036882

DE - Bevollmächtigter für technische Dokumentation CS - Oprávněná osoba pro technickou dokumentaci DA - Autoriseret person for teknisk dokumentation EN - Authorized person for technical documentation FI - Valtutettu henkilö tekninen dokumentaatio FR - Personne autorisée à la documentation technique HU - Hivatalos személy műszaki dokumentáció IT - Persona abilitata per la documentazione tecnica NL - Bevoegd persoon voor technische documentatie PL - Pełnomocnik ds. dokumentacji technicznej RO - Persoană autorizată pentru documentație tehnică SK - Oprávněná osoba pro technickou dokumentaci SV - Auktoriserad person för teknisk dokumentation:

JUNG PUMPEN - Stefan Sirges - Industriestr. 4-6 - 33803 Steinhagen

Steinhagen, 30-11-2018

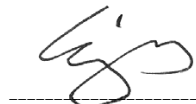

Stefan Sirges, General Manager



i.V. Rüdiger Rokohl, Sales Manager



Spare parts

PLANCOFIX PLUS (JP47014) • PLANCOFIX LINE (JP50177)

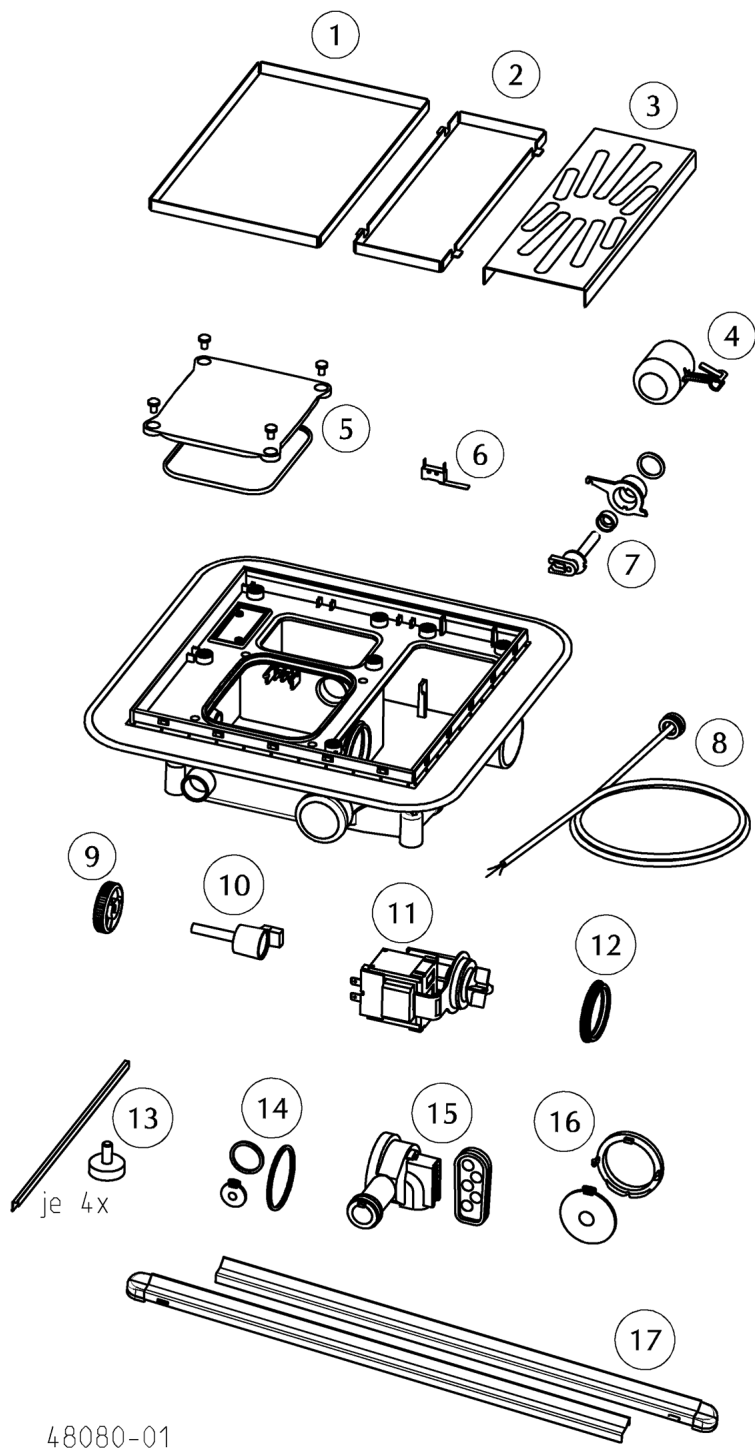

①	Abdeckung	Cover	
	Plancofix plus		JP45594
	Plancofix line		JP50199
②	Abdeckung, klein	Cover small	JP45595
③	Ablaufrost	Grid	JP45596
④	Schwimmer	Float	JP45598
⑤	Deckel Motorraum	Cover for motor	JP45597
⑥	Mikroschalter	Micro switch	JP45599
⑦	Schaltwelle	Switch cam	JP48072
⑧	Netzleitung	Cable	JP45603
⑨	Motorspanner	Motor clamp	JP48073
⑩	Schraube u. Puffer	Screw and buffer	JP48104
⑪	Motor	Motor	JP48074
⑫	Motordichtung	Motor sealing	JP48075
⑬	Zubehör	Accessories set	
	Plancofix plus		JP48076
	Plancofix line		JP50209
⑭	Dichtungen, hydr.	Seals, hydraulic	JP48077
⑮	Hydraulik	Hydraulic	JP48078
⑯	Zulaufklappe	Inlet flap	JP48089
⑰	Rinne	Drain channel	JP50194

48080-01



**PUMP TECHNICAL
SERVICES LIMITED**

