

EASYFIX

DRAINAGE PUMPS

- Quick and easy installation
 - Easyfix 32 Duo incl. control unit
 - Ready to connect
 - Guide rail system
- pre-assembled on base plate
 - Compact design allows use in small chamber: 400x250 mm for single units / 500x500 mm for double units



DESCRIPTION

With the Easyfix 32 Single or Easyfix 32 Duo installation sets, drainage pumps can be installed as single or duplex pump stations in existing sumps inside or outside buildings with minimum (time) effort.

The sets are ready-to-use in and all necessary components are already pre-assembled on a base plate (H=15 mm) up to the connection to the pressure pipe.

In addition to the mechanical components, the Easyfix 32 Duo also includes a control unit. This control unit regulates the alternating operation of the two pumps and also ensures alarm messages and peak load operation. The pumps are operated by their regular attached float switches, so no external level control such as submersible ball float switches are required.

The U3 KS, U3 KS spezial, U5 KS and U6 K ES can be connected to both Easyfix sets. The pumps are not included in the scope of supply. The use of the special float for low switching points (pump accessory) is possible.

PERFORMANCE

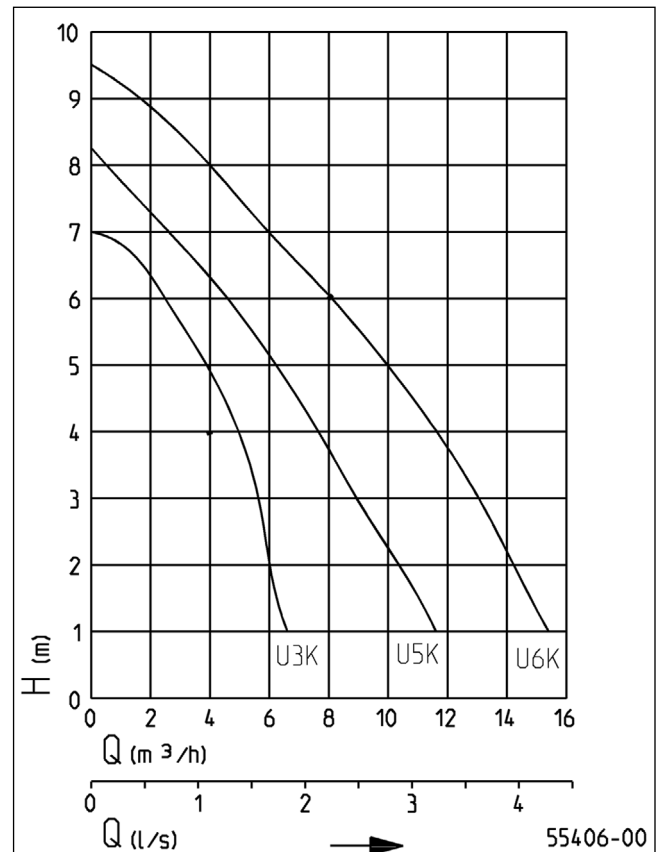

We reserve the right to change specifications without notice. Pump performance is subject to ISO 9906 tolerances

The minimum flow velocity in the pressure piping must be 0.7 m/s according to EN 12056. This data is represented in the performance curve as a limit of application.

EASYFIX

DRAINAGE PUMPS

SCOPE OF SUPPLY

Easyfix 32 Single: Guide rail system on base plate, pressure pipe with check valve (completely pre-assembled), guide rail claw, flexible connection and clamps.

Easyfix 32 Duo: 2x guide rail system system on base plate, pressure pipes with check valves (completely pre-assembled), guide rail claws, flexible connection, clamps and control unit.

EASYFIX

Type	Code No.	Weight
Easyfix 32 Duo	JP50307	6.9 kg
Easyfix 32 Single	JP50308	1.8 kg

POSSIBLE PUMPS

Easyfix	U3KS spezial	U6K ES
U3 KS	U5KS	

Dimensions Easyfix 32 Single (mm)

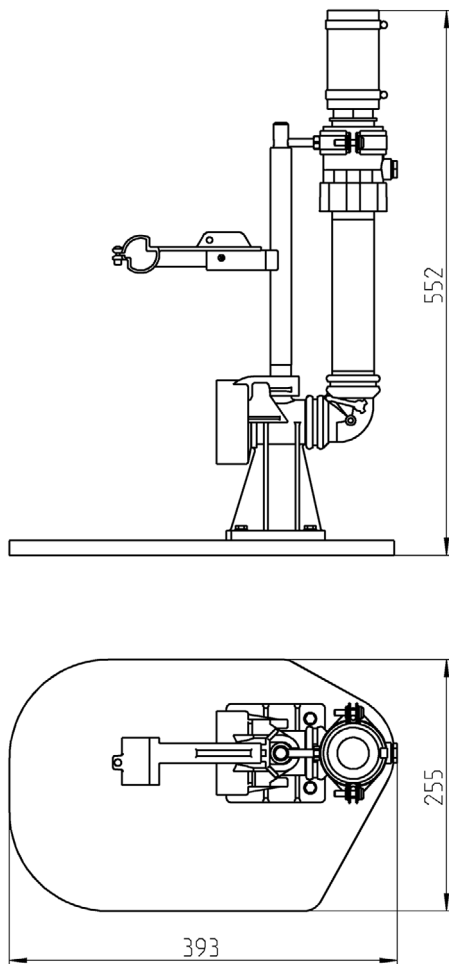

Dimensions Easyfix 32 Duo (mm)

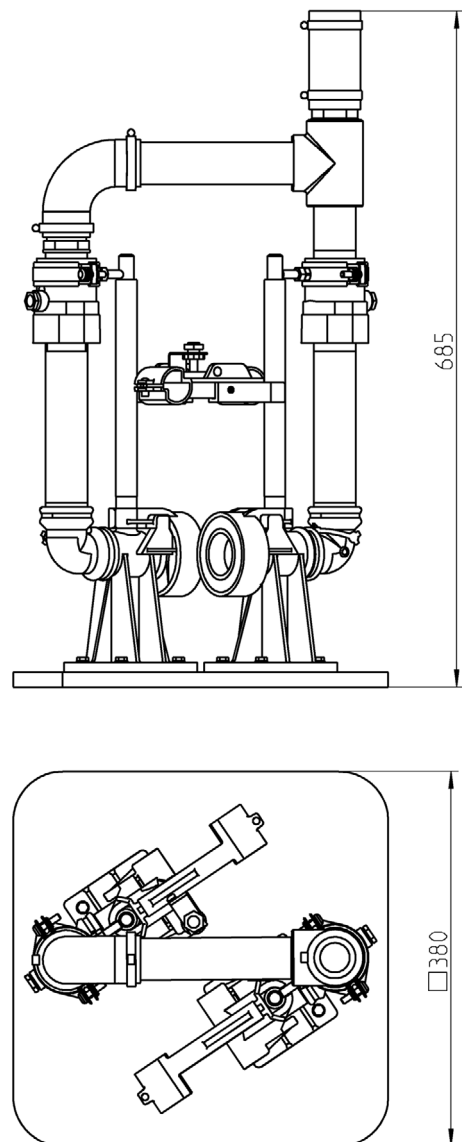

EASYFIX

DRAINAGE PUMPS

Dimensions and switching points Easyfix 32 Single (mm)

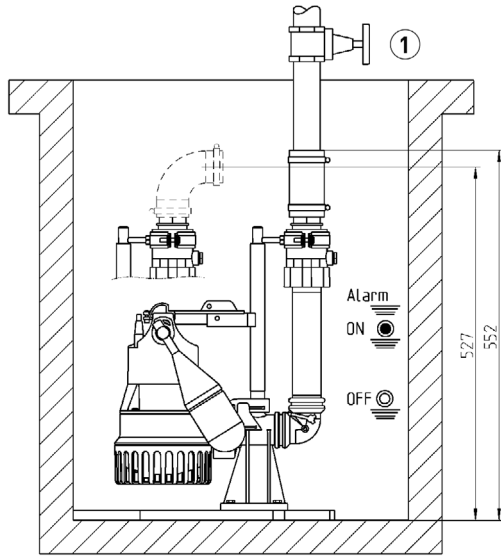

	U3 KS	U5 KS	U6K ES
ON	270	275	295
OFF	165	170	195
Alarm	320	345	400

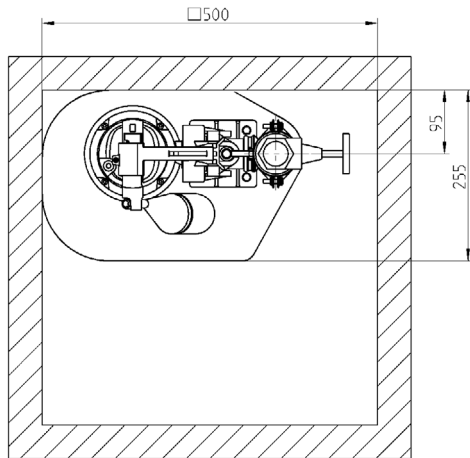

55351-00

Dimensions and switching points speical float (mm)

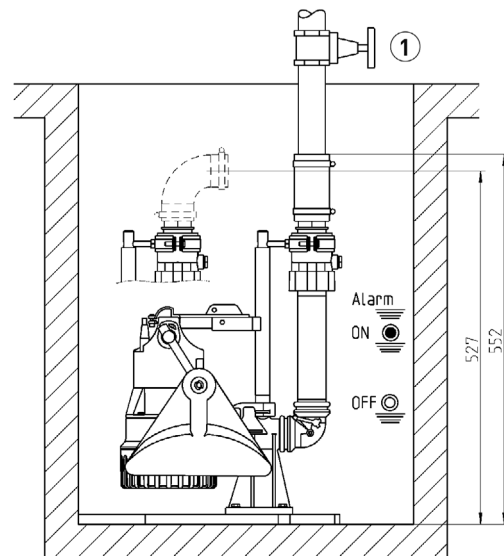

	U3 KS	U5 KS	U6K ES
ON	160	125	155
OFF	100	75	105
Alarm	320	345	400

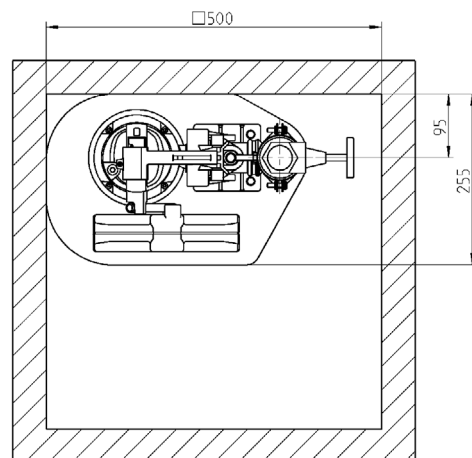

55352-00

EASYFIX

DRAINAGE PUMPS

Example of installation Easyfix 32 Duo

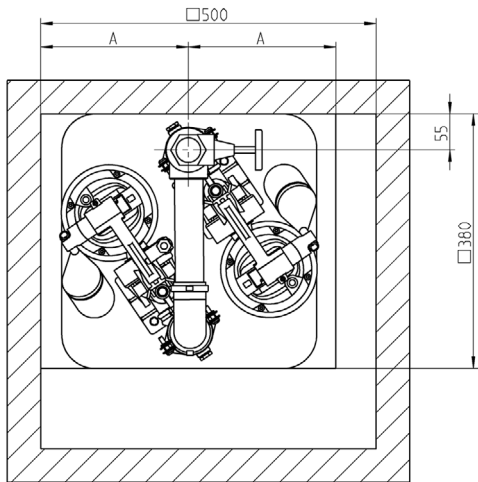
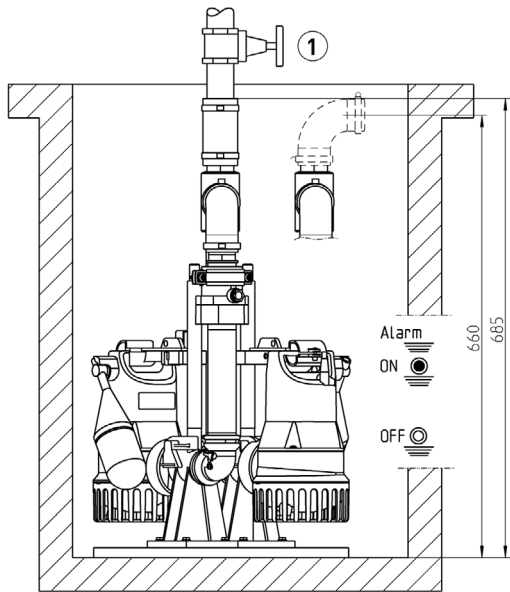

	U3 KS	U5 KS	U6K ES
ON	270	275	295
OFF	165	170	195
Alarm	320	345	400

	U3 KS	U5 KS	U6K ES
A	min.220	min.242	min.250

55348-00

Example of installation Easyfix 32 Duo with special float

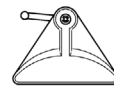
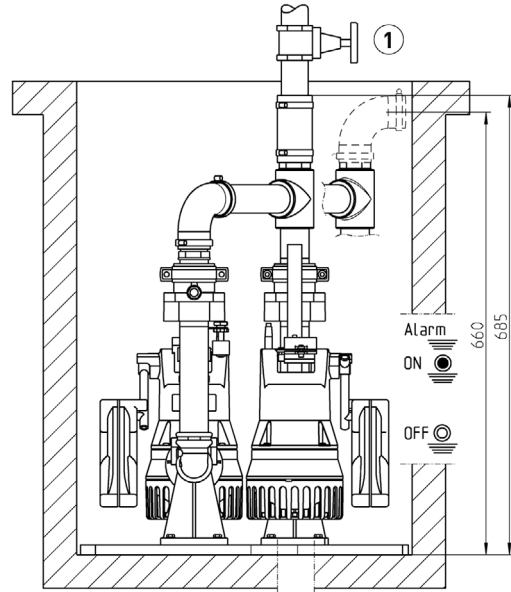

	U3 KS	U5 KS	U6K ES
ON	160	125	155
OFF	100	75	105
Alarm	320	345	400

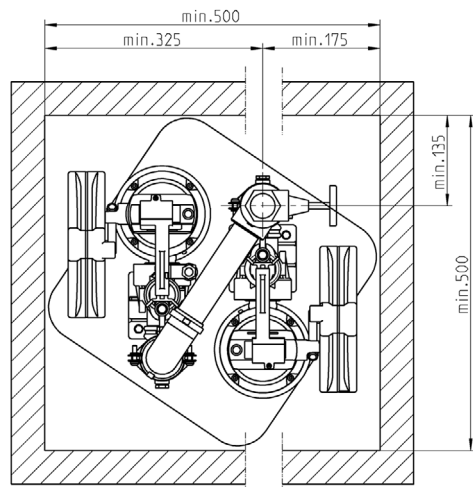

55349-00

MECHANICAL ACCESSORY

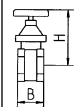

① Stop valve

1/4" (DN 32), PN 16

110x60 (HxB)

Code No.

JP44785

EASYFIX

DRAINAGE PUMPS

ELECTRICAL ACCESSORY

			Code No.
	a Rechargeable battery	for mains independent alarm	JP44850

EASYFIX

DRAINAGE PUMPS