

- Pressure stabilizer sump
- Single- or duplex unit
- Floor drain with odour trap
- Level-compensating frame
- Seal collar for attaching to the customer's thin-bed waterproofing system
- Use in groundwater areas possible
- Guide rail system GR 32 or GR 50 possible



DESCRIPTION

Baufix 200 is for bigger domestic wastewater volume and larger storage capacity. Without requiring a great deal of construction work, it disposes of domestic wastewater from laundries, storage or cellar areas.

Baufix 200 can be installed as a single as well as duplex system. The required components for the installation of the pump are part of the scope of supply. The duplex system provides bigger security in the disposal in wastewater. In normal operation the two pumps operate alternately or at the same time to cope with peak load.

If the system is to be operated as a single system, a pump with a built-in level control must be selected.

The pump to be placed can be selected according to the amount of wastewater. The dirty water to be transported and the pumping power required have to be taken into consideration in particular. In case of slightly dirty water, pumps U3K, U5K or U6K E+D can be used. If the admixtures are larger or the volume of wastewater is bigger, the use of a pump of the US series is recommendable. Pumps US 73+103 Ex are used in hazardous areas. In case of commercial applications, the resistance of the materials have to be tested in advance. Depending on the type of pump used, the Hebefix 200-32 with 1¼" or the Hebefix 200-50 with 2" discharge branch has to be chosen.

Without formwork, the pressure-resistant plastic PE sump is placed into the concrete bed and forms a collecting tank for underfloor pipework. The installation in areas with high ground water levels is possible without extension and under the use of the groundwater seal.

By subsequently adjusting the plastic cover frame, the sump cover can be adapted easily and variably to the floor and tile conditions.

The unit is in conformity with the specification of German / European standard DIN EN 12050.

Specifications can be changed without notice. Performance subject to ISO 9906 tolerances.

PERFORMANCE

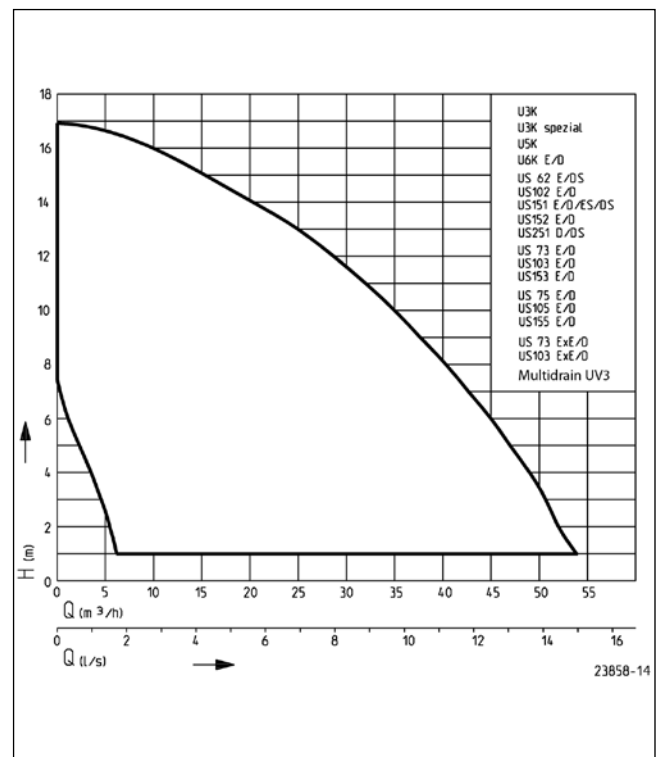

BAUFIX 200

UNDERFLOOR SUMP

SCOPE OF SUPPLY

Plastic sump to house a pump tested in keeping with German/
European standard EN 12050 with shaped connecting piece,
level-compensating plastic cover frame, cover plate and odour

trap for floor drain, hose connection and pressure pipe, two
swing-type check valves, plug for cable conduit, without pumps.

MECHANICAL DATA

Tank capacity	240 l
---------------	-------

BAUFIX 200

Type	Code No.	Weight
Baufix 200-32	JP48186	30 kg
Baufix 200-50	JP48187	37 kg

POSSIBLE PUMPS

Baufix 200-32	US 103 E/D Ex	US 103 E/D
U3K/U3K spezial	Multidrain UV3	US 153 E/D
U5K	Baufix 200-50	US 75 E/D
U6K E/D	US 62 E/D	US 105 E/D
US 62 D/E	US 102 E/D	US 155 E/D
US 102 E/D	US 151 E/D	US 73 E/D Ex
US 73 E/D	US 152 E/D	US 103 E/D Ex
US 103 E/D	US 251 D	
US 73 E/D Ex	US 73 E/D	

BAUFIX 200

UNDERFLOOR SUMP

Dimensions Baufix 200-32 (mm)

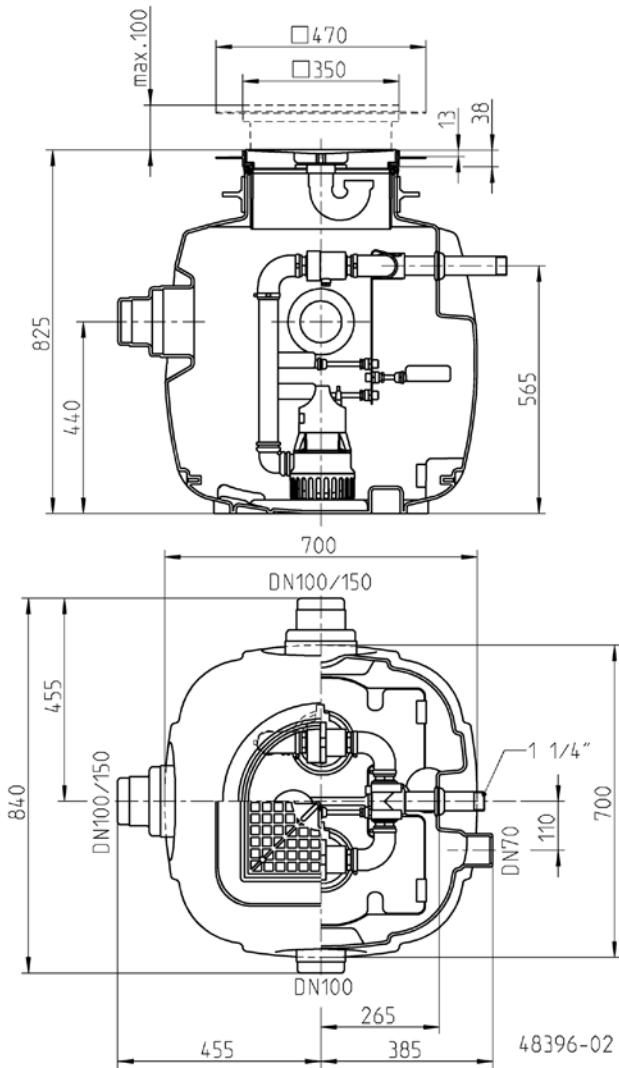

Dimensions Baufix 200-50 (mm)

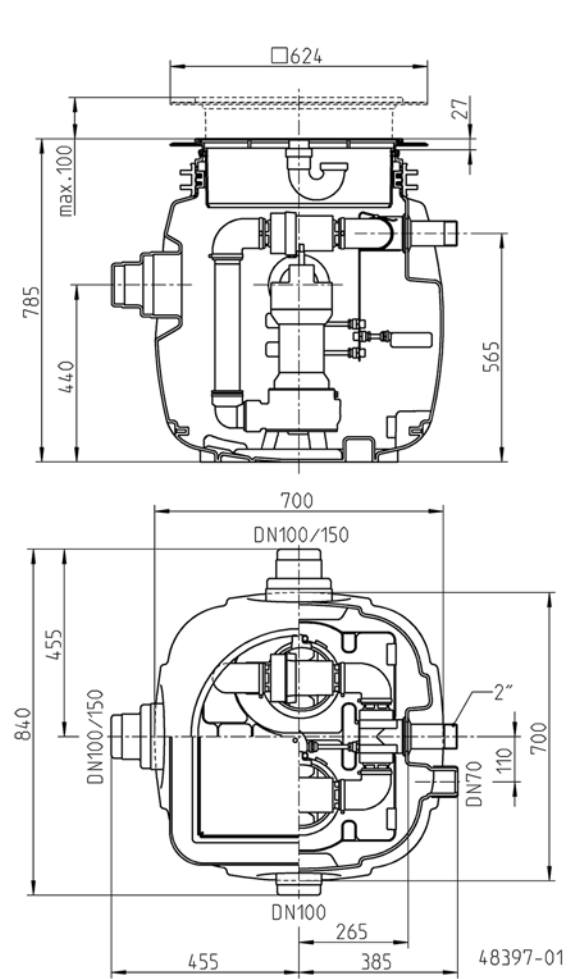





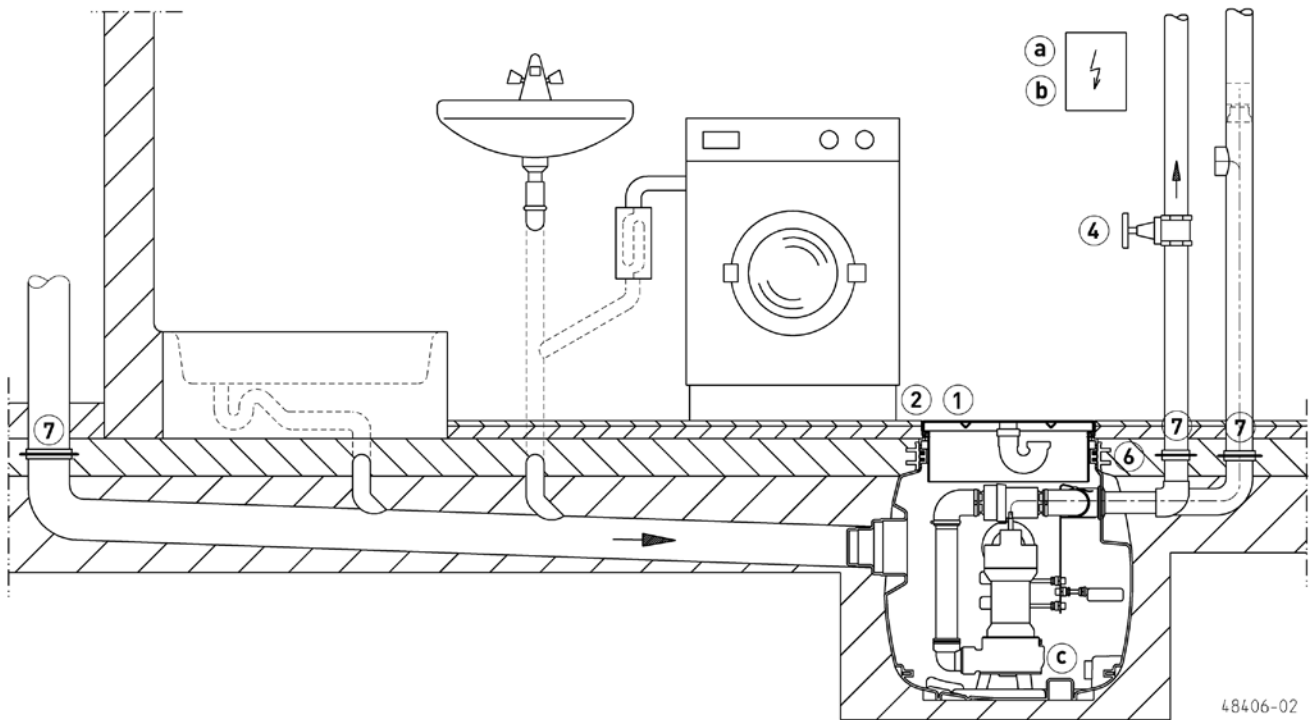

BAUFIX 200

UNDERFLOOR SUMP

Example of installation Baufix 200

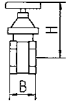



MECHANICAL ACCESSORY

				Code No.
	1 Cover plate	stainless steel, to be tiled, for Baufix 50, Baufix 100, Baufix 200-32		JP24024
	2 Cover frame	stainless steel, for Baufix 50, Baufix 100, Baufix 200-32		JP28118
	3 Special ventilation	special filter with housing, not for hot water		JP27484
	4 Stop valve	1/4" (DN 32), PN 16	110x60 (HxB)	JP44785
		brass, 1/2" (DN 40), PN 16	125x60 (HxB)	JP44786
		brass, 2" (DN 50), PN 16	140x70 (HxB)	JP44787
	Ball valve	1/4", PVC, for aggressive media	105x155 (HxB)	JP46111
	5 Guide rail system	Guide rail system GR32 for Hebefix 200/Baufix 200 (U3/U5/U5)		JP48279
		Guide rail system GR50 for Hebefix 200/Baufix 200 (US75/US105/US155)		JP48280
	Securing levers	for US 75, US 105, US 155, stainless steel		JP41024
	6 Ground water seal sump	Ø315 for Baufix 100/Baufix 200-32		JP47216
		Ø500 for Baufix 200-50/Vacubox 200		JP48215
	7 Ground water seal set	for Baufix 100/Baufix 200-32 with inlet DN 100		JP50206
		for Baufix 200-32 with inlet DN 150		JP50205
		for Baufix 200-50/Vacubox 200 with inlet DN 100		JP50204
		for Baufix 200-50/Vacubox 200 with inlet DN 150		JP50203
	8 Sump extension	165-265 mm for Baufix 200-50/Vacubox 200		JP48282

BAUFIX 200

UNDERFLOOR SUMP

ELECTRICAL ACCESSORY

		Code No.	
	a Control for duplex units		
	Control unit HIGHLOGO 2-00 E	230 V	JP47996
	Control unit BD 00 E	230 V, for pumps U3-U6, US 62-105, UV3, UV 300, 08/2 ME	JP45735
	Control unit HIGHLOGO 2-00	400 V	JP47997
	Control unit BD 00	400 V, for pumps U6, US 62-105, UV 300	JP45993
	Control unit HIGHLOGO 2-25	400 V	JP47998
	Control unit BD 25	400 V, for pumps US 151-155	JP45737
	Control unit BD 610 EC	230 V, with operating capacitor	JP45743
	Control unit BD 46	400 V, for pumps US 251-253, UV 620-3, UV 625-3	JP45739
	Control unit BD 23 X	for US 73 D EX	JP09755
	Control unit BD 25 X	for US 103 D EX	JP09681
	Level control		
Dry run protection		JP44603	
Submersible switch pack B232	for Hebefix 200-32 / Baufix 200-32	JP48228	
Submersible switch pack B250	for Hebefix 200-50 / Baufix 200-50 / Vacubox 200	JP48229	
Submersible switch pack BF232	for grease-containing wastewater	JP48298	
Submersible switch pack BF250	for grease-containing wastewater	JP48299	
Auxiliary switch unit ExH-B for explosion-proof pumps only	for ex-proof pumps only (duplex units)	JP00295	
Alarm unit			
AG3	subm. ball contact switch, mains dependent, potential-free contact, 3 m cable	JP44891	
AG10	subm. ball contact switch, mains dependent, potential-free contact, 9.5 m cable	JP44892	
Washing machine stop			
AW3	subm. ball contact switch, mains dependent, 3 m cable	JP44895	
AW0	for alarm forwarding in case of several washing machines	JP44899	
	b Rechargeable battery	JP44850	
	9 V, for mains independent alarm		
	c Seal leak detector	JP44900	
	DKG		
	DKG Ex for explosion-proof pumps	JP00249	