



**PUMP TECHNICAL  
SERVICES LIMITED**



**THE SUBMERSIBLE PUMP SPECIALISTS**

MANUFACTURING | SALES | PROJECT DESIGN | INSTALLATION | MAINTENANCE AND REPAIRS

## COMPLI

300 E		1010/4 BWE
	510/4 BW	1010/4 BW
400 E	515/4 BW	1015/4 BW
400	525/4 BW	1025/4 BW
425/2 BW	525/2 BW	1025/2 BW
435/2 BW	535/2 BW	1035/2 BW
108/2 ME	508/2 ME	1008/2 ME
108/2 M	508/2 M	1008/2 M
120/2 M	520/2 M	1020/2 M

EN Instruction Manual

---

You have purchased a product made by Pentair Jung Pumpen and with it, therefore, also excellent quality and service. Secure this service by carrying out the installation works in accordance with the instructions, so that our product can perform its task to your complete satisfaction. Please remember that damage caused by incorrect installation or handling will adversely affect the guarantee. Therefore please adhere to the instructions in this manual!

This appliance can be used by children aged 8 years or over and by persons with limited physical, sensory or intellectual capabilities, or with limited experience and knowledge, provided that they are supervised or have been instructed in the safe use of the appliance and are aware of the dangers involved. Children must not be allowed to play with the appliance. Cleaning and user maintenance must not be carried out by children unless they are supervised.

If this unit is equipped with a mains connection line without a plug or other means of disconnection from the mains, a complete disconnecting device must be installed on site in the fixed electrical installation in accordance with the installation regulations. A main switch of overvoltage category III can be installed as a complete disconnecting device. If the mains connection cable of this unit is damaged, it must be replaced by the manufacturer or its customer service or a similarly qualified person in order to avoid hazards.

### Damage prevention in case of failure

Like any other electrical device, this product may fail due to a lack of mains voltage or a technical defect.

If damage (including consequential damage) can occur as a result of product failure, the following precautions can be taken at your discretion:

- Installation of a water level dependent (under circumstances, mains-independent) alarm system, so that the alarm can be heard before damage occurs.
- Inspection of the collecting tank/chamber for tightness up to the top edge before – or at the latest, during – installation or operation of the product.
- Installation of backflow protection for drainage units that can be damaged by wastewater leakage upon product failure.
- Installation of a further product that can compensate in case of failure of the other product (e.g. duplex unit).
- Installation of an emergency power generator.

As these precautions serve to prevent or minimise consequential damage upon product failure, they are to be strictly observed as the manufacturer's guideline – in line with the standard DIN EN specifications as state of the art – when using the product (Higher Regional Court Frankfurt/Main, Ref.: 2 U 205/11, 06/15/2012).

## SAFETY INSTRUCTIONS

This instruction manual contains essential information that must be observed during installation, operation and servicing. It is therefore important that the installer and the responsible technician/operator read this instruction manual before the equipment is installed and put into operation. The manual must always be available at the location where the pump or the plant is installed.

Failure to observe the safety instructions can lead to the loss of all indemnity.

In this instruction manual, safety information is distinctly labelled with particular symbols. Disregarding this information can be dangerous.



General danger to people



Warning of electrical voltage

**NOTICE!** Danger to equipment and operation

### Qualification and training of personnel

All personnel involved with the operation, servicing, inspection and installation of the equipment must be suitably qualified for this work and must have studied the instruction manual in depth to ensure that they are sufficiently conversant with its contents. The supervision, competence and areas of responsibility of the personnel must be precisely regulated by the operator. If the personnel do not have the necessary skills, they must be instructed and trained accordingly.

### Safety-conscious working

The safety instructions in this instruction manual, the existing national regulations regarding accident prevention, and any internal working, operating and safety regulations must be adhered to.

### Safety instructions for the operator/user

All legal regulations, local directives and safety regulations must be adhered to.

The possibility of danger due to electrical energy must be prevented.

Leakages of dangerous (e.g. explosive, toxic, hot) substances must be discharged such that no danger to people or the environment occurs. Legal regulations must be observed.

### Safety instructions for installation, inspection and maintenance works

As a basic principle, works may only be carried out to the equipment when it is shut down. Pumps or plant that convey harmful substances must be decontaminated.

All safety and protection components must be re-fitted and/or made operational immediately after the works have been completed. Their effectiveness must be checked before restarting, taking into account the current regulations and stipulations.

### Unauthorised modifications, manufacture of spare parts

The equipment may only be modified or altered in agreement with the manufacturer. The use of original spare parts and accessories approved by the manufacturer is important for safety reasons. The use of other parts can result in liability for consequential damage being rescinded.

## Unauthorised operating methods

The operational safety of the supplied equipment is only guaranteed if the equipment is used for its intended purpose. The limiting values given in the "Technical Data" section may not be exceeded under any circumstances.

## Instructions regarding accident prevention

Before commencing servicing or maintenance works, cordon off the working area and check that the lifting gear is in perfect condition.

Never work alone. Always wear a hard hat, safety glasses and safety shoes and, if necessary, a suitable safety belt.

Before carrying out welding works or using electrical devices, check to ensure there is no danger of explosion.

People working in wastewater systems must be vaccinated against the pathogens that may be found there. For the sake of your health, be sure to pay meticulous attention to cleanliness wherever you are working.

Make sure that there are no toxic gases in the working area.

Observe the health and safety at work regulations and make sure that a first-aid kit is to hand.

In some cases, the pump and the pumping medium may be hot and could cause burns.

For installations in areas subject to explosion hazards, special regulations apply!

## AREAS OF APPLICATION

The Compli sewage lifting stations are TÜV certified and are suitable for the disposal of wastewater from toilets and urinals, and domestic wastewater containing the usual impurities.

The units have a level controller that switches the pump on and off depending on the level of the water. An integrated alarm system beeps if there is a malfunction, even if this is only temporary.

If the pump overheats, the motor cuts out due to the winding thermostat. After the thermostat has switched off the system, pull out the mains plug before remedying the fault, since the device can switch itself on again automatically if the power is still connected. A direct malfunction message is not generated.

The tanks can withstand submersion to a depth of not more than 2 m of water and a submersion period of up to 7 days.

The control unit cannot withstand submersion, but is splash-proof in accordance with IP 44.

If installed in Compliance with the regulations and used properly, then this control unit meets the protective requirements of the EMC Directive 2014/30/EU and is suitable for domestic use and connection to a power supply from the grid. When connected to an industrial mains within an industrial operation with power supply provided by a company-own high-voltage transformer, insufficient immunity to interference has to be expected.

When using the pumps, the relevant national laws, regulations and stipulations must be adhered to, for example:

- Sewage disposal units for building and ground drainage systems (e.g. EN 12050 and 12056 in Europe)
- Installation of low voltage systems (e.g. VDE 0100 in Germany)
- Safety and working materials (e.g., BetrSichV and BGR 500

in Germany)

- Safety in wastewater systems (e.g., GUV-V C5, GUV-R 104 and GUV-R 126 in Germany)
- Electrical systems and operating resources (e.g., GUV-V A3 in Germany)
- Explosion protection EN 60079-0, EN 60079-1, EN 60079-14, EN 60079-17 and EN 1127-1

## Scope of supply

- Tank with pump(s)
- Clamp flange / socket for inlet
- Reducing adapter for inlet DN 150 to DN 100
- Slip-on socket pipe for ventilation pipe
- Connection flange for pressure pipe
- Reducing adapter for pressure pipe DN 100 to DN 80
- Non-return valve for the pressure pipe (Compli 100, 300, 500, and 1000)
- Flexible connection with hose clamps for the pressure pipe
- Plug-in seal(s) for the diaphragm hand pump or additional inlet DN 50
- Fixing materials for tank
- Control



**NOTICE!** Transport lock = protection against buoyancy of the container

**Mode of operation:** intermittent operation S3; see "Technical Data".

## INSTALLATION

The pump must be installed so that it is buoyancy-proof and free-standing. At least 60 cm free working space must be provided around and above the parts that require access for operation or maintenance.

Ventilation: The ventilation pipe must be vented above roof level.

Inlet: A wastewater sluice valve must be installed in the inlet at the front of the tank.

Pressure pipe: A further wastewater sluice valve must be installed behind the non-return valve in the pressure pipe. If the non-return valve is not included in the scope of delivery of the pumping unit, then an EN certified swing-type check valve must be fitted.

The pressure pipe must be laid in a loop above the local backup level.

**NOTICE!** The pressure pipe of the Compli 300/400 must be supported or suspended by the customer. The weight must not rest on the system.

A pump sump must be provided to facilitate the disposal of water from the pump installation area.

**NOTICE!** All bolts that are used for fixing individual components to the tank should be tightened with a torque of no more than 6 Nm.

## Installing the tank

**Compli 300.** Close the sluice valve in the inlet (accessory) to prevent any leakage of water during the installation work.

Select the DN 100 inlet you wish to use and open this inlet at



the side or at the top at the markings using a 102 Ø hole saw or a jigsaw. Then deburr the edges. Fix the enclosed clamp flange loosely to the inlet with the hexagon screws.

Take the brackets that are used to fix the unit in place and screw them to the tank. Then take the unit with the clamp flange and push it onto the inlet pipe as far as it will go.

Mark the positions of the wall plugs on the floor, then drill the holes and push in the wall plugs.

Now the clamp flange can be tightened and the unit can be anchored to the floor using the wood screws and shims.

**Compli 400.** Close the sluice valve in the inlet (accessory) to prevent any leakage of water during the installation work.

The inlet height is continuously adjustable, see technical data.

The unit must be slid onto the inlet pipe as far as possible and then aligned.

If a DN 100 side inlet is used, the inlet must first be opened at the marked position using a hole saw, Ø 102, and then deburred. The standard inlet must then be closed using a closure kit (accessory) and the switch-on level must be reset.

Slide the floor fixings into the side "pockets" of the tank and then anchor them to the floor with the plugs and screws.

**All other Compli.** Close the sluice valve in the inlet (accessory) to prevent any leakage of water during the installation work.

Units must be slid onto the inlet pipe, together with the clamp flange, as far as possible and then aligned.

If a DN 150 side inlet is used, the inlet must first be opened at the marked position using a hole saw, Ø 152, and then deburred. The standard inlet must then be closed using a closure kit (accessory) and the switch-on level must be reset.

In the case of Compli 500 and 1000, the inlet can be reduced from DN 150 to DN 100 if the enclosed reducer is first of all fitted to the clamp flange.

Tighten the hexagon screws on the clamp flange.

Mark the positions of the holes for fixing the tank to the floor, then drill the holes.

Insert the wood screw, together with the washer and wall plug, into the drill hole in the tank and tighten it.

**NOTICE!** Ensure that the tank does not become deformed due to overtightening the screws, otherwise this could result in leakage.

### Installing the ventilation

Connect the ventilation pipe to the top right of the tank using the DN 70 slip-on socket pipe and vent it above roof level.

### Installing the pressure pipe

**Compli 300.**

**NOTICE!** For simplified maintenance of the non-return valve

Fit the following to the non-return valve:

1. Discharge flange
2. Flexible connector
3. Connection flange (by customer, min. 200 long)
4. Stop valve (accessory)
5. Connect the pressure pipe and loop it over the local backup level.

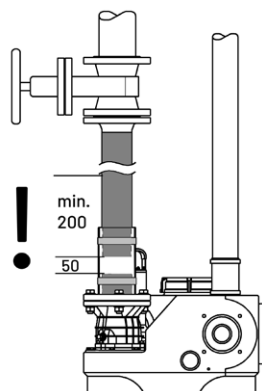

### Compli 400

**NOTICE!** When replacing a compli 400 with horizontal pressure line, the elastic connection can be shortened.

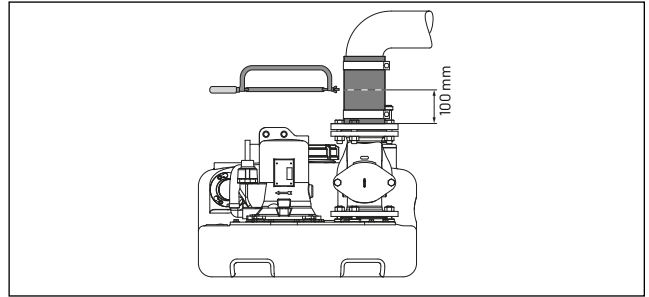

**All other Compli.** Fit the following to the discharge flange:

1. Non-return valve (if not included in scope of supply)
2. Stop valve (accessory)
3. Connection flange and
4. connect the pressure pipe with the flexible connector and loop it over the local backup level.

### Additional connection, DN 50, vertical

This connection is used for emergency disposal.

Open the pipe connection at the marking using a hole saw, deburr the edges. and put the plug-in seal, 58/50, into place.

- Mounting Compli emergency supply connection (accessory)
- Mounting hand diaphragm pump (accessory)

Push the inlet pipe, with an external diameter of 50 mm, into the tank through the plug-in seal. The distance from the bottom of the tank must be at least 50 mm.

Fix the diaphragm hand pump to the wall in an easily accessible position. Connect it to the pushed-in pipe and then connect the pressure pipe to the diaphragm hand pump. Here, too, the pressure pipe must be looped over the local backup level.

### Additional inlet, DN 50, horizontal

Using a hole saw, open the additional inlet by cutting along the pre-cut groove. Deburr the edges.

Put the plug-in seal, 58/50, into place.

Push the inlet pipe, with an external diameter of 50 mm, into the tank through the plug-in seal.

**NOTICE!** The pipes that connect to the low-level inlets on the side of the unit must be fitted with a bend, as close to the unit as possible. The pipe invert of this bend must be at a height of at least 180 mm above the floor on which the unit is fixed. Air pockets in the connecting pipe can cause run-off problems and the water could back-up. To prevent back-ups, the inlet pipe must be vented at its highest point. The ventilation pipe can be connected into the tank ventilation.

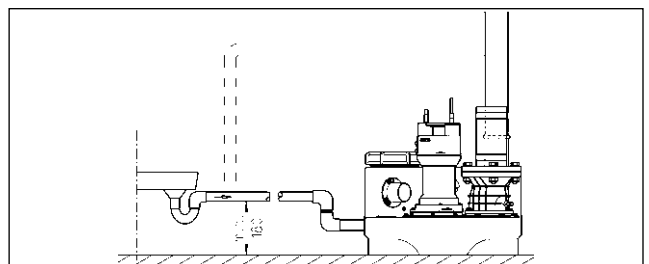

### Installing control unit

**NOTICE!** Only qualified electricians may carry out electrical

works to the pump or the controls.

**NOTICE!** Never put the mains plug or open cable end in water! If water gets into the plug, this can cause malfunctions and damage.

Not compli 300. Only operate the control unit in dry rooms and keep the housing closed at all times. The control unit must be easily accessible to enable it to be checked at any time. High humidity and condensation can destroy the controls!

#### Alternating current (AC) units with plug

Only connect the pump to electrical sockets that have been installed properly in a dry room, in accordance with the regulations, and are fitted with at least a 16 A (delay) fuse and RCD-safety switches (30mA).

#### Three-phase current units with plug

For the electrical connection of the sewage disposal unit, a five pole CEE power socket is required. This must be located in a dry room (3/N/PE~230/400 V) and RCD-safety switches (30mA).

**NOTICE!** Only slow-blow fuses or automatic fuses with C characteristics are to be used as pre-fuses for the pump. See circuit diagram.

#### Installations with free cable end

If this unit is equipped with a mains connection line without a plug or other means of disconnection from the mains, a complete disconnecting device must be installed on site in the fixed electrical installation in accordance with the installation regulations. A main switch of overvoltage category III can be installed as a complete disconnecting device.

#### Installations without mains connection line with main switch

If this unit is equipped without a mains connection line, a complete disconnecting device must be installed on site in the fixed electrical installation in accordance with the installation regulations. A main switch of overvoltage category III can be installed as a complete disconnecting device. The mains connection line is connected directly to the main switch.

**NOTICE!** Only slow-blow fuses or automatic fuses with C characteristics are to be used as pre-fuses for the pump.

See circuit diagram.

#### Switching levels

The switch-on and switch-off points have been factory set for the standard inlet height for the units. If you select a different inlet height, then you must redefine the switch-on point. The other switching points for the alarm and peak load are then reset automatically by the control unit.

#### Redefining the switch-on level



Loosen the three screws and turn the lid all the way to the left, counterclockwise.

Fill the tank with water up to the desired switch-on level. Carefully turn the lid clockwise until the pump starts.

Now tighten the three screws again, the new switch-on level is set.

## Alarm

- In the case of Compli 300, the runtime is monitored. If the

pumping process takes longer than 50 +/- 5 seconds, an alarm is triggered. Pull the plug to acknowledge the alarm.

- All other Compli. Malfunction messages are given both optically as well as acoustically. The standard mains-dependent alarm system reports motor faults in the pump and high water. At the same time a built-in acoustic alarm sounds. In the case of the Compli 1000, this acoustic signal can only be turned off by rectifying the fault. On the Compli 100, 400 and 500, the signal can be acknowledged with the "RESET" button on the housing.
- If an acoustic signal would be inappropriate at the installation site in question, an alarm signal can be relayed via the potential-free contact (terminals 40 and 41) on the circuit board (in the plug in the case of Compli 300). The potential-free contact of the centralised alarm can be loaded with a maximum of 5 A / 250 VAC. The contact opens after the fault has been remedied.

## Battery pack for alarm system

Not compli 300. The alarm device is mains-dependent in its standard version, i.e. it is not possible to trigger a high-water alarm in the event of a power failure. To enable the alarm device to work even if there is a power failure, a rechargeable battery pack must be used. Open the door. Connect the battery pack to the connection clip, and use the existing cable ties to attach it to the intended position (G1) on the PCB. The battery pack can supply the alarm system with power for about 1 hour in case of permanent alarm.

After return of the mains voltage, the battery pack is charged again automatically. An empty battery is ready for operation within approx. 24 hours. It is fully charged after about 100 hours.

Check the function of the battery pack at regular intervals! To do so, disconnect the unit from the mains and trigger a high-water alarm. The volume of the acoustic signal must not become significantly quieter over a period of several minutes. The service life is about 5 years. Note the insertion date on the battery pack and after five years the battery pack should be replaced as a precautionary measure.

### CAUTION!

Only use the 9V-NiMh battery supplied by the manufacturer! If dry-cell batteries or Lithium batteries are used there is a danger of explosion!

## Shutting down the internal alarm buzzer

Not compli 300. Remove the sealed jumper (BRX/BRX1). To prevent the jumper from getting lost, attach it to a pin of the two-pole pin connector.

## Accessory: External alarm buzzer

Open the door of the control unit.

An additional separate acoustic 12 VDC signal transmitter with a current consumption of not more than 30 mA can be connected to terminals "S+" and "S-". The internal alarm buzzer can either be switched on or off.

In the case of compli 300 and 400, a mains-independent alarm device can be fitted as an accessory. There is a mounting base on the tank for this purpose.

## Accessory: Separate high water level sensor

A separate high-water level sensor can be fitted on the compli

400, which triggers an additional high-water alarm acoustically and visually (LED AUX input). A mounting base is provided on the tank. The connection to the control unit is made via the AUX input (clamps 51 and 52). The alarm goes off when the water level in the tank has fallen.

### Accessory: Time meter

An optional time meter can be fitted in the control unit (not compli 300). To do so, shorten the connections of the time meter to approx. 8 mm and insert them into the four sockets at location BSZ on the printed circuit board. If there is no time meter indication after switching on the unit again, rotate the time meter through 180°.

### Accessory Compli 1000: External 230V~ flashing light or warning light

Connect a 230V~ lamp (1 A max.) to terminals N and 41.

Lay an insulated wire bridge from terminal U~ to terminal 40. The electric circuit is protected by F1.

Set Jumper BRX2 as follows: Flashing light without BRX2 (Continuous ==) Warning light with BRX2 (Flashing (–|–|–))

### Test run and functional check

1. Open the maintenance cover of the tank.
2. Open the shut-off valves in the inlet and the pressure pipe.
3. Connect the unit to the power supply and observe the indication for the rotating field direction.
4. Fill the tank up to the switch-on level.
5. The pump will now switch on and empty the tank. Observe the pumping process through the maintenance opening.
6. Lift the float of the level controller slowly by hand until it is above the switch-on point and hold it there until the alarm is triggered.
7. Then close the maintenance opening with the cover and seal.
8. Check to ensure that the tank, fittings and pipes are watertight, by carrying out several switching runs.

## OPERATION

### Automatic operation

Automatic operation is the normal operating mode of the unit. The rocker switch must be set to "Automatic". The integrated level controller switches the pump on and off depending on the water level in the tank. A green LED lights up when the pump is operating (in the case of Compli 300 when it is ready for operation).

**NOTICE!** If unusually large quantities of wastewater flow into the unit (e.g. when a pool is drained), partially close the shut-off valve at the inlet until the unit can operate normally again, switching on and off, (S3 Intermittent duty, not pumping continuously, since this could overheat the pump motor).

### Manual operation

Set the rocker switch to "Hand". The pump will now operate permanently and independently of the wastewater level. The pumping out operation should therefore be observed through the maintenance opening.

### Shutting down

Set the rocker switch to "0". This shuts down the pump. The alarm system remains ready for operation.

### DANGER!

Do not use the position "0" of the selector switch for repair and maintenance work on the control and pump, but always unplug the unit from the mains.

### Inspection

To maintain operational reliability, carry out a visual inspection of the unit, including the pipe connections, once a month.

## MAINTENANCE

Maintenance and inspection of this product must be carried out in accordance with EN 12056-4. To ensure continued reliability of service, we recommend that you take out a service contract.

**NOTICE!** The maintenance of the sewage lifting station and maintenance measures are carried out by specialists at intervals of 3 months in commercial premises, multi-family homes in 6 months or 12 months in family homes.

### WARNING!

Before carrying out any works: disconnect the pump and the controls from the mains and take steps to ensure that they cannot be energized again.

### WARNING!

Check the cable for mechanical or chemical damage. Damaged or kinked cables must be replaced by the manufacturer.

We recommend that the following works be included in the service:

1. Check the connection points for watertightness and inspect the areas surrounding the unit and the fittings.
2. Operate the shut-off valves and check that they move easily. Adjust and grease them if necessary.
3. Open and clean the swing-type check valve; check the seat and valve (ball)
4. Clean the pump and the pipes where they connect to the unit; check the impeller and the bearings.

### CAUTION!

Worn impellers can have sharp edges.

5. Oil check. If necessary top up or change oil (if oil chamber available).
6. Clean the inside of the tank (as necessary, or if especially required); remove any grease, for example.
7. Check the condition of the collecting tank.
8. Flush the system through with water once every 2 years.
9. Inspect the electrical section of the unit. The control unit itself is maintenance-free, but if a rechargeable battery is fitted, then it should be checked regularly to ensure that it is in good working order. To do so, unplug the unit from the mains and lift the float of the level controller slowly by hand and hold it there until the alarm is triggered.
10. In addition, clean the float if necessary.

When all the servicing tasks have been performed, carry out a

test run and then put the unit back into operation. The service must be documented, giving details of the important data and of all the tasks carried out.

#### Resetting the maintenance reminder (if available)

■ ■ Set switches S3 and S4 on the control unit circuit board to the up position (RESET ON). After approximately 3 seconds P6 will flash 3 times.

(If the switches remain in position, the maintenance reminder is deactivated).

Now set the new reminder interval

1 year   , 1/2 year   or 1/4 year   .

#### Oil check

(Only applies for units 08/2, 20/2, 25/2 and 35/2). First of all, unscrew the hexagon screws or Allen screws around the pump and lift the pump and impeller off the tank. The drain plug is labelled "Öl". In order to check the mechanical seal, the oil, including any residue, must be drained from the oil reservoir and collected in a clean measuring container.

- If the oil is contaminated with water (milky), an oil change must be carried out. Check again after a further 300 operating hours, but at the very latest after 6 months!
- However, if the oil is contaminated with both water and pollutants, then not only the oil must be replaced, but the mechanical seal as well.

For monitoring the oil reservoir, it is also possible to retrofit the electrode of our "DKG" seal leak detector in place of the "DKG" sealing screw.

#### Changing the oil

(Only applies for units 08/2, 20/2, 25/2 and 35/2). To ensure operational liability, the first oil change should be carried out after 300 operating hours, with further oil changes carried out after every 1000 operating hours.

If the number of operating hours is very low, an oil change should still be carried out at least once a year.

If wastewater with strongly abrasive constituents is being pumped, the oil changes should be carried out at correspondingly shorter intervals.

Use HLP hydraulic mineral oil, viscosity class 22 to 46, e.g. Mobil DTE 22, DTE 24, DTE 25, to replace the oil in the oil reservoir.

The quantity of oil required is 380 cm<sup>3</sup> for the MultiCut pumps UC 08/2 M and UC 20/2 M, and 700 cm<sup>3</sup> for the MultiFree pumps UC 25/2 BW and 35/2 BW.

**NOTICE!** The oil reservoir may only be filled with the specified quantity of oil. Overfilling will result in the pump being rendered inoperable.

#### Checking the cutting clearance

Only for pumps with cutting system. The housing screws for the pump, and the connecting and fixing screws of the installation must be checked to ensure they are fixed securely. They should be tightened if necessary.

If the pump performance decreases, or if increasingly loud noises can be heard during operation, or if the cutting performance decreases (the pump tends to become blocked), the impeller and cutting system must be checked for wear by an expert and replaced if necessary.

Using a suitable tool, e.g. feeler gauge, the cutting clearance between the cutting rotor and the cutting plate can be measured. A cutting clearance of over 0.2 mm must be reduced.

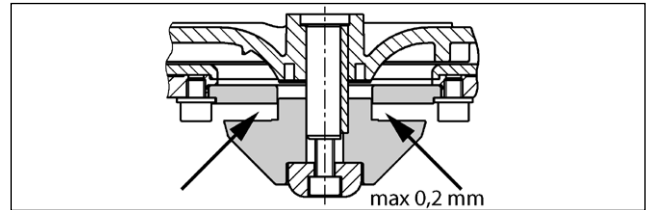

#### Adjustment of the cutting clearance

1. Block the cutting rotor with a piece of wood and unscrew the central hexagon socket screw.
2. Take off the compression piece, the cutting rotor and an adjusting washer and then attach the compression piece and the cutting rotor again.
3. Block the cutting rotor and tighten again with the hexagon socket screw (tightening torque 8 Nm).
4. Check the freedom of movement of the cutting rotor and the cutting clearance again (max. 0.2 mm).

If the cutting clearance is still too big, a further adjusting washer must be removed. Steps 1-4 must be repeated.

## QUICK TIPS FOR REMEDYING FAULTS

#### The unit isn't working

- Check the mains voltage, the fuse and the ground fault circuit interrupter. Replace defective fuses only with fuses with the same nominal value! If the fuse triggers again, call a qualified electrician or our customer support service.
- The internal 2 A glass tube fuse (delay) for the 230/12V control transformer, the motor contactor and the 230V AC power supply are faulty. Replace defective fuses only with fuses with the same nominal value!
- If the mains cable is damaged, it may only be replaced by the manufacturer.
- If the float switch is obstructed, close the inlet shut-off valve, open the maintenance cover and clear the blockage.

#### If the alarm is triggered and the unit does not work:

- The thermostat in the motor windings may have switched off the system because the pump is obstructed. In this case, close the shut-off valve at the inlet, drain the tank, pull out the mains plug, remove the pump module, and clear the blockage.

#### Decreased pumping performance

- Check that the shut-off valve in the pressure pipe is fully open.
- If the pressure pipe is blocked, flush water through the pressure pipe to clear it.
- If the non-return valve is blocked, empty the pressure pipe and clean the non-return valve.
- If the ventilation system is blocked, clean the ventilation hose that leads from the pump tank and check the drilled holes.

- If the unit works normally when it starts pumping, but becomes very loud towards the end, then a qualified electrician must redefine the switch-off point in the control unit.

**Indicator "Drehfeld falsch" (Wrong rotating field) lights up**



- Mains phase sequence is wrong or phase is absent - thus lower or absent pump delivery. The mains connection must be corrected by a qualified electrician only.

**Indicator "Störung Pumpe" (Pump failure) lights up (not compli 300)**

- The pump is protected by an integrated circuit breaker which switches off the pump if it overloads or if there is an electric motor fault. After this has been triggered, the control unit has to be opened by a qualified electrician in order to press the reset button.

**Indicator "Hochwasser" (High water) lights up (not compli 300)**

- Water level in the tank too high because of low pump flow rate or excessive inflow. Remove any obstructions in the pump or pressure pipe and/or eliminate the excessive inflow.

 0197	JUNG PUMPEN GmbH - Industriestr. 4-6 33803 Steinhagen, Germany 20 466.13.2023.04	 0197	JUNG PUMPEN GmbH - Industriestr. 4-6 33803 Steinhagen, Germany 20 466.13.2023.04	 0197	JUNG PUMPEN GmbH - Industriestr. 4-6 33803 Steinhagen, Germany 20 466.13.2023.04
<b>EN 12050-1:2001; 2015</b> <b>Station de relevage pour effluents contenant des matières fécales</b>	Compli 300 E (JP50076) Compli 400 E (JP50081) Compli 400 E (JP50082) Compli 400 (JP50079) Compli 400 (JP50080) Compli 510/4 BW (JP50091) Compli 515/4 BW (JP50092) Compli 525/4 BW (JP50093) Compli 525/2 BW (JP50094) Compli 535/2 BW (JP50095) Compli 1010/4 BWE (JP50099) Compli 1010/4 BWE, 15m (JP50113) Compli 1010/4 BWE, 15m (JP50114) (JP50111) Compli 1010/4 BW (JP50100) Compli 1015/4 BW (JP50101)	EN 12050-1:2001; 2015 <b>Fäkalienhebeanlage</b> Compli 300 E (JP50076) Compli 400 E (JP50081) Compli 400 E (JP50082) Compli 400 (JP50079) Compli 400 (JP50080) Compli 510/4 BW (JP50091) Compli 515/4 BW (JP50092) Compli 525/4 BW (JP50093) Compli 525/2 BW (JP50094) Compli 535/2 BW (JP50095) Compli 1010/4 BWE (JP50099) Compli 1010/4 BWE, 15m (JP50111) Compli 1010/4 BW (JP50100) Compli 1015/4 BW (JP50101)			
<b>EN 12050-1:2001; 2015</b> <b>Lifting plant for wastewater containing faecal matter</b>	Compli 300 E (JP50086) Compli 400 E (JP50186) Compli 400 R80 15M GB (JP50167) Compli 400 R80 4M GB (JP50782) Compli 400E R80 4M GB (JP50783) Compli 510/4 BW (JP50731) Compli 515/4 BW (JP50732) Compli 525/4 BW (JP50733) Compli 525/2 BW (JP50734) Compli 535/2 BW (JP50735) Compli 1010/4 BWE (JP50690) Compli 1010/4 BWE, 15M (JP50720) Compli 1010/4 BW (JP50721) Compli 1015/4 BW (JP50722)	EN 12050-1:2001; 2015 <b>Fäkalienhaltigem Abwasser über die Rückstauenebene</b> Compli 1025/4 BW (JP50723) Compli 1025/2 BW (JP50724) Compli 1035/2 BW (JP50725) COMPLI 108/2 ME (JP50689) COMPLI 108/2 M (JP50761) COMPLI 120/2 M (JP50762) COMPLI 508/2 ME (JP50728) COMPLI 508/2 M (JP50729) COMPLI 520/2 M (JP50730) COMPLI 1008/2 ME (JP50692) COMPLI 1008/2 M (JP50728) COMPLI 1020/2 M (JP50727)			
<b>EN 12050-1:2001; 2015</b> <b>Collecte et relevage automatique des eaux usées exemptes de matières fécales et des eaux usées contenant des matières fécales au-dessus du niveau de refoulement.</b>	Collecte et relevage automatique des eaux usées exemptes de matières fécales et des eaux usées contenant des matières fécales au-dessus du niveau de refoulement.	Sammeln und automatisches Heben von fäkalienfreiem und fäkalienhaltigem Abwasser über die Rückstauenebene			
<b>REACTION AU FEU</b> <b>ÉTANCHÉITÉ À L'EAU, ÉTANCHÉITÉ À L'AIR</b> - Étanchéité à l'eau - Étanchéité aux odeurs	NPD satisfaisant satisfaisant	BRANDVERHALTEN WASSERDICHTHEIT, LUFTDICHTHEIT - Wasserdichtheit - Geruchsdichtheit			
<b>EFFICACITÉ (PERFORMANCE DE RELEVAGE)</b> - Refoulement de matières solides - Raccords de tuyaux - Dimensions minimales des conduites d'aération - Débit minimum - Passage libre minimal de l'installation - Volume utile minimal	satisfaisant satisfaisant satisfaisant satisfaisant satisfaisant satisfaisant	WIRKSAMKEIT (HEBEWIRKUNG) - Förderung von Feststoffen - Rohranschlüsse - Mindestmaße von Lüftungsleitungen - Mindestfließgeschwindigkeit - Freier Mindestdurchgang der Anlage - Mindestnutzolumen			
<b>RÉSISTANCE MÉCANIQUE</b> - Capacité de charge et stabilité structurelle du collecteur pour une utilisation à l'extérieur des bâtiments - Stabilité structurelle du collecteur pour une utilisation à l'intérieur des bâtiments	NPD satisfaisant	MECHANISCHE FESTIGKEIT - Tragfähigkeit und strukturelle Stabilität des Sammelbehälters für die Verwendung außerhalb von Gebäuden - Strukturelle Stabilität des Sammelbehälters für die Verwendung innerhalb von Gebäuden			
<b>NIVEAU SONORE</b> <b>RÉSISTANCE</b> - de la stabilité structurelle - de la performance de relevage - de la résistance mécanique <b>SUBSTANCES DANGEREUSES</b>	70 dB(A) satisfaisant satisfaisant satisfaisant NPD	GERÄUSCHPEGEL <b>DAUERHAFTIGKEIT</b> - der Wasserdichtheit und Luftdichtheit - der Hebewirkung - der mechanischen Festigkeit <b>GEFÄHRLICHE SUBSTANZEN</b>			



0197

JUNG PUMPEN GmbH - Industriestr. 4-6 33803 Steinhagen, Germany  
20  
466.13.2023.04

**EN 12050-1:2001; 2015****Instalacja przepompowni fekaliiów**

Compli 300 E (JP50076) Compli 1025/4 BW (JP50102)  
Compli 400 E (JP50081) Compli 1025/2 BW (JP50103)  
Compli 400 E (JP50082) Compli 1035/2 BW (JP50104)  
Compli 400 (JP50079) Compli 108/2 ME (JP50088)  
Compli 400 (JP50080) Compli 108/2 M (JP50089)  
Compli 510/4 BW (JP50091) Compli 120/2 M (JP50090)  
Compli 515/4 BW (JP50092) Compli 508/2 ME (JP50096)  
Compli 525/4 BW (JP50093) Compli 508/2 M (JP50097)  
Compli 525/2 BW (JP50094) Compli 520/2 M (JP50098)  
Compli 535/2 BW (JP50095) Compli 1008/2 ME (JP50112)  
Compli 1010/4 BWE (JP50099) Compli 1008/2 M (JP50113)  
Compli 1010/4 BWE, 15m (JP50111) Compli 1020/2 M (JP50114)  
Compli 1010/4 BW (JP50100)  
Compli 1015/4 BW (JP50101)

Zbieranie i automatyczne przepompowywanie ścieków bez fekaliiów i ścieków fekalnych powyżej poziomu cofki



0197

JUNG PUMPEN GmbH - Industriestr. 4-6 33803 Steinhagen, Germany  
20  
466.13.2023.04

**EN 12050-1:2001; 2015****Stazione di sollevamento per acque reflue contenenti materiale fecale**

Compli 300 E (JP50076) Compli 1025/4 BW (JP50102)  
Compli 400 E (JP50081) Compli 1025/2 BW (JP50103)  
Compli 400 E (JP50082) Compli 1035/2 BW (JP50104)  
Compli 400 (JP50079) Compli 108/2 ME (JP50088)  
Compli 400 (JP50080) Compli 108/2 M (JP50089)  
Compli 510/4 BW (JP50091) Compli 120/2 M (JP50090)  
Compli 515/4 BW (JP50092) Compli 508/2 ME (JP50096)  
Compli 525/4 BW (JP50093) Compli 508/2 M (JP50097)  
Compli 525/2 BW (JP50094) Compli 520/2 M (JP50098)  
Compli 535/2 BW (JP50095) Compli 1008/2 ME (JP50112)  
Compli 1010/4 BWE (JP50099) Compli 1008/2 M (JP50113)  
Compli 1010/4 BWE, 15m (JP50111) Compli 1020/2 M (JP50114)  
Compli 1010/4 BW (JP50100)  
Compli 1015/4 BW (JP50101)

Raccolta e sollevamento automatico di acque reflue prive di sostanze fecali e di acque reflue contenenti sostanze fecali al di sopra del livello di ristagno



0197

JUNG PUMPEN GmbH - Industriestr. 4-6 33803 Steinhagen, Germany  
20  
466.13.2023.04

**EN 12050-1:2001; 2015****Fecaliënpompinstallatie**

Compli 300 E (JP50076) Compli 1025/4 BW (JP50102)  
Compli 400 E (JP50081) Compli 1025/2 BW (JP50103)  
Compli 400 E (JP50082) Compli 1035/2 BW (JP50104)  
Compli 400 (JP50079) Compli 108/2 ME (JP50088)  
Compli 400 (JP50080) Compli 108/2 M (JP50089)  
Compli 510/4 BW (JP50091) Compli 120/2 M (JP50090)  
Compli 515/4 BW (JP50092) Compli 508/2 ME (JP50096)  
Compli 525/4 BW (JP50093) Compli 508/2 M (JP50097)  
Compli 525/2 BW (JP50094) Compli 520/2 M (JP50098)  
Compli 535/2 BW (JP50095) Compli 1008/2 ME (JP50112)  
Compli 1010/4 BWE (JP50099) Compli 1008/2 M (JP50113)  
Compli 1010/4 BWE, 15m (JP50111) Compli 1020/2 M (JP50114)  
Compli 1010/4 BW (JP50100)  
Compli 1015/4 BW (JP50101)

Verzamelen en automatisch pompen van afvalwater zonder fecaliën en afvalwater met fecaliën boven het terugstuwniveau

**WŁAŚCIWOŚCI: OGNIOWE**

SZCZELNOŚĆ WODNA I POWIETRZNA  
- Szczelność wodna  
- Szczelność zapachowa

**SPRAWNOŚĆ DZIAŁANIA (SKUTECZNOŚĆ TŁOCZENIA)**

- Przyłącza rurowe  
- Wymiary minimalne przewodów wentylacyjnych  
- Minimalna prędkość przepływu  
- Minimalna, swobodna przepustowość instalacji  
- Minimalna objętość użytkownika

**WYTRZYMAŁOŚĆ MECHANICZNA**

- Nośność i stabilność konstrukcyjna zbiornika podczas stosowania poza budynkami  
- Nośność i stabilność konstrukcyjna zbiornika podczas stosowania w budynkach

**POZIOM HAŁĄS**

70 dB(A)

**TRWAŁOŚĆ I WYTRZYMAŁOŚĆ**

- stabilność konstrukcyjna  
- skuteczność tłoczenia  
- wytrzymałość mechaniczna

**SUBSTANCJE NIEBEZPIECZNE**

NPD

**INFIAMMABILITÀ**

IMPERMEABILITÀ, ERMETICITÀ ALL'ARIA  
- Impermeabilità  
- Emeticità agli odori

**EFFICACIA (CAPACITÀ DI SOLLEVAMENTO)**

- Pompaggio di materiali solidi  
- Collegamenti al tubo  
- Misure minime delle linee di ventilazione  
- Velocità di scorrimento minima  
- Passaggio libero minimo dell'impianto  
- Volume utile minimo

**RESISTENZA MECCANICA**

- Capacità di carico e stabilità strutturale del serbatoio di raccolta per l'uso al di fuori degli edifici  
- Stabilità strutturale del serbatoio di raccolta per l'uso all'interno degli edifici.

**SOGLIA DI RUMOROSITÀ**

70 dB(A)

**DUREVOLEZZA**

- della stabilità strutturale  
- della capacità di sollevamento  
- della resistenza meccanica

**SOSTANZE PERICOLOSE**

NPD

**BRANDGEDRAG**

WATERDICHTHEID; LUCHTDICHTHEID  
- Waterdichtheid  
- Geurdichtheid

**RENDEMENT (POMPWERKING)**

- Transport van vaste stoffen  
- Buisaansluitingen  
- Minimum afmeting van verluchtingsleidingen  
- Minimum doorstromingssnelheid  
- Minimum vrije doorgang van de installatie  
- Minimum nuttig volume

**MECHANISCHE VASTHEID**

- Draagkracht en structurele stabiliteit van de verzamelcontainer voor het gebruik buiten gebouwen  
- Structurele stabiliteit van de verzamelcontainer voor het gebruik binnenin gebouwen

**GELUIDSNIVEAU**

70 dB(A)

**DUURZAAMHEID**

- van de structurele stabiliteit  
- van de pompwerking  
- van de mechanische vastheid

**GEVAARLIJKE STOFFEN**

NPD

 0197 JUNG PUMPEN GmbH - Industriestr. 4-6 33803 Steinhagen, Germany 20 466.13.2023.04	<b>EEN 12050-1:2001; 2015</b> <b>Čerpací stanice odpadních vod s fekáliemi</b>	Compili 300 E (JP50076) Compili 400 E (JP50081) Compili 400 E (JP50082) Compili 400 (JP50079) Compili 400 (JP50080) Compili 510/4 BW (JP50091) Compili 515/4 BW (JP50092) Compili 525/4 BW (JP50093) Compili 525/2 BW (JP50094) Compili 535/2 BW (JP50095) Compili 1010/4 BWE (JP50099) Compili 1010/4 BWE, 15m (JP50111) Compili 1010/4 BW (JP50100) Compili 1015/4 BW (JP50101)	Compili 1025/4 BW (JP50102) Compili 1025/2 BW (JP50103) Compili 1035/2 BW (JP50104) Compili 108/2 ME (JP50088) Compili 108/2 M (JP50089) Compili 120/2 M (JP50090) Compili 508/2 ME (JP50096) Compili 508/2 M (JP50097) Compili 520/2 M (JP50098) Compili 1008/2 ME (JP50112) Compili 1008/2 M (JP50113) Compili 1020/2 M (JP50114)	Sběr a automatické čerpání odpadních vod bez fekálií a odpadních vod s fekáliemi nad úroveň zpětného vzduťi	NPĐ vyhovuje vyhovuje vyhovuje vyhovuje vyhovuje vyhovuje NPĐ vyhovuje 70 dB(A) vyhovuje vyhovuje vyhovuje NPĐ
		CHOVÁNÍ PŘI POŽÁRU VODOTĚSNOST, VZDUCHOTĚSNOST - Vodotěsnost - Pachová těsnost ÚČINNOST (ZDVIH) - Doprava pevných látek mimo přípojky - Potrubní přípojky - Minimální rozměry větracího vedení - Minimální průtoková rychlost - Volný minimální prostup zařízení - Minimální užitkový objem MECHANICKÁ PEVNOST - Nosnost a strukturální stabilita sběrné nádrže pro použití mimo budovy - Strukturální stabilita sběrné nádrže pro použití uvnitř budov	HLÚČNOST STÁLOST - Strukturální stability - Zdvíhu - Mechanické pevnosti NEBEZPEČNÉ SUBSTANCE		

 0197 JUNG PUMPEN GmbH - Industriestr. 4-6 33803 Steinhagen, Germany 20 466.13.2023.04	<b>EN 12050-1:2001; 2015</b> <b>Čerpací stanice odpadových vod s obsahom fekálních splašků</b>	Compili 300 E (JP50076) Compili 400 E (JP50081) Compili 400 E (JP50082) Compili 400 (JP50079) Compili 400 (JP50080) Compili 510/4 BW (JP50091) Compili 515/4 BW (JP50092) Compili 525/4 BW (JP50093) Compili 525/2 BW (JP50094) Compili 535/2 BW (JP50095) Compili 1010/4 BWE (JP50099) Compili 1010/4 BWE, 15m (JP50111) Compili 1010/4 BW (JP50100) Compili 1015/4 BW (JP50101)	Compili 1025/4 BW (JP50102) Compili 1025/2 BW (JP50103) Compili 1035/2 BW (JP50104) Compili 108/2 ME (JP50088) Compili 108/2 M (JP50089) Compili 120/2 M (JP50090) Compili 508/2 ME (JP50096) Compili 508/2 M (JP50097) Compili 520/2 M (JP50098) Compili 1008/2 ME (JP50112) Compili 1008/2 M (JP50113) Compili 1020/2 M (JP50114)	Zber a automatické čerpanie odpadových vod bez fekálních a odpadových vod s obsahom fekálních splašků prostredníctvom úroveň vzduťia	NPĐ v poriadku v poriadku v poriadku v poriadku v poriadku v poriadku NPĐ v poriadku 70 dB (A) v poriadku v poriadku v poriadku NPĐ
		REAKCIA POČAS POŽIARU VODOTĚSNOST, VZDUCHOTĚSNOST - vodotěsnost - pachová bezpečnost ÚČINNOST (ÚČINOK SANIA) - doprava pevných částic - potrubní přípojky - minimální rozměry větracího vedení - minimální rychlost průtoku - volný minimální přechod systému - minimální užitkový objem MECHANICKÁ PEVNOST - nosnost a strukturální stabilita zbernej nádrže pre používanie mimo budov - strukturálna stabilita zbernej nádrže pre používanie v rámci budov HLADINA HLUKU TRVANLIVOSŤ - strukturálnej stability - vedľajších účinkov - mechanickej pevnosti NEBEZPEČNÉ LÁTKY	REAKCIA POČAS POŽIARU VODOTĚSNOST, VZDUCHOTĚSNOST - vodotěsnost - pachová bezpečnost ÚČINNOST (ÚČINOK SANIA) - doprava pevných částic - potrubní přípojky - minimální rozměry větracího vedení - minimální rychlost průtoku - volný minimální přechod systému - minimální užitkový objem MECHANICKÁ PEVNOST - nosnost a strukturální stabilita zbernej nádrže pre používanie mimo budov - strukturálna stabilita zbernej nádrže pre používanie v rámci budov HLADINA HLUKU TRVANLIVOSŤ - strukturálnej stability - vedľajších účinkov - mechanickej pevnosti NEBEZPEČNÉ LÁTKY		

 0197 JUNG PUMPEN GmbH - Industriestr. 4-6 33803 Steinhagen, Germany 20 466.13.2023.04	<b>EN 12050-1:2001; 2015</b> <b>Fekálietartalmú szennyvízek áttelelői</b>	Compili 300 E (JP50076) Compili 400 E (JP50081) Compili 400 E (JP50082) Compili 400 (JP50079) Compili 400 (JP50080) Compili 510/4 BW (JP50091) Compili 515/4 BW (JP50092) Compili 525/4 BW (JP50093) Compili 525/2 BW (JP50094) Compili 535/2 BW (JP50095) Compili 1010/4 BWE (JP50099) Compili 1010/4 BWE, 15m (JP50111) Compili 1010/4 BW (JP50100) Compili 1015/4 BW (JP50101)	Compili 1025/4 BW (JP50102) Compili 1025/2 BW (JP50103) Compili 1035/2 BW (JP50104) Compili 108/2 ME (JP50088) Compili 108/2 M (JP50089) Compili 120/2 M (JP50090) Compili 508/2 ME (JP50096) Compili 508/2 M (JP50097) Compili 520/2 M (JP50098) Compili 1008/2 ME (JP50112) Compili 1008/2 M (JP50113) Compili 1020/2 M (JP50114)	Fekália mentes szennyvíz és fekália tartalmú szennyvíz gyűjtése és emelése a visszatörődási szint felett	NPĐ Megfelelt Megfelelt Megfelelt Megfelelt Megfelelt Megfelelt NPĐ Megfelelt 70 dB(A) Megfelelt Megfelelt Megfelelt NPĐ
		VISELKEDÉS TŰZ ESETÉN VIZÁLÓSÁG, LEGÁTERESZTÉS - Vizálóság - Szagmentesség HATÉKONYSÁG (EMELŐ HATÁS) - Szilárd anyagok szállítása - Csőcsatlakozások - A szellőzővezetékek minimális méretei - Az áramlás minimális sebessége - A berendezés szabad, minimális átteresztése - Minimális hasznos volumen MECHANIKAI SZILÁRDSÁG - A gyűjtőtartály terhelhetősége és strukturális stabilitása épületeken kívüli használatához - A gyűjtőtartály strukturális stabilitása épületeken belüli használatához ZAJSZINT TARTOSSÁG - a strukturális stabilitás tartóssága - az emelőhatás tartóssága - a mechanikai szilárdság tartóssága VESZÉLYES ANYAGOK	VISELKEDÉS TŰZ ESETÉN VIZÁLÓSÁG, LEGÁTERESZTÉS - Vizálóság - Szagmentesség HATÉKONYSÁG (EMELŐ HATÁS) - Szilárd anyagok szállítása - Csőcsatlakozások - A szellőzővezetékek minimális méretei - Az áramlás minimális sebessége - A berendezés szabad, minimális átteresztése - Minimális hasznos volumen MECHANIKAI SZILÁRDSÁG - A gyűjtőtartály terhelhetősége és strukturális stabilitása épületeken kívüli használatához - A gyűjtőtartály strukturális stabilitása épületeken belüli használatához ZAJSZINT TARTOSSÁG - a strukturális stabilitás tartóssága - az emelőhatás tartóssága - a mechanikai szilárdság tartóssága VESZÉLYES ANYAGOK		



JUNG PUMPEN GmbH - Industriest. 4-6-33803 Steinhagen, Germany 20 466.13.2023.04		
<b>EN 12050-1:2001; 2015</b> <b>Stație de pompare ape uzate cu materii fecale</b>		
Compi 300 E (JP50076) Compi 400 E (JP50081) Compi 400 E (JP50082) Compi 400 (JP50079) Compi 400 (JP50080) Compi 510/4 BW (JP50091) Compi 515/4 BW (JP50092) Compi 525/4 BW (JP50093) Compi 525/2 BW (JP50094) Compi 535/2 BW (JP50095) Compi 1010/4 BWE (JP50099) Compi 1010/4 BWE, 15m (JP50111) Compi 1010/4 BW (JP50100) Compi 1015/4 BW (JP50101)	Compi 1025/4 BW (JP50102) Compi 1025/2 BW (JP50103) Compi 1035/2 BW (JP50104) Compi 108/2 ME (JP50088) Compi 108/2 M (JP50089) Compi 120/2 M (JP50090) Compi 508/2 ME (JP50096) Compi 508/2 M (JP50097) Compi 520/2 M (JP50098) Compi 1008/2 ME (JP50112) Compi 1008/2 M (JP50113) Compi 1020/2 M (JP50114)	
Colectarea și pomparea automată de ape uzate fără materii fecale și ape uzate cu materii fecale deasupra nivelului maxim posibil al apelor uzate din sistemul de canalizare		
<b>COMPORTAMENTUL ÎN CAZ DE INCENDIU</b> IMPERMEABILITATE LA APĂ, ETANȘEITATE LA AER - Impermeabilitate la apă - Etanșeitate la mirosuri EFICACITATE (EFICIENȚĂ DE POMPARE) - Transportul de materiale solide - Racorduri țevă - Dimensiuni minime ale conductelor de ventilație - Viteza de curgere minimă - Trecerea minimă liberă a instalației - Capacitate utilizabilă minimă REZISTENȚA MECANICĂ - Capacitatea portantă și stabilitatea structurală a rezervoarelor pentru utilizarea în afara clădirilor - Stabilitatea structurală a rezervorului colector pentru utilizarea în interiorul clădirilor NIVEL DE ZGOMOT DURABILITATEA - Stabilitatea structurală - Eficiență de pompare - Rezistența mecanică SUBSTANȚE PERICULOASE		NPD Reușit Reușit Reușit Reușit Reușit Reușit Reușit NPD Reușit 70 dB(A) Reușit Reușit Reușit NPD

EU-Konformitätsklärung EU-Prohlásení o shodě EU-Överensstemmelseerklaring EU-Declaration of Conformity EU-Vaatimustennäköisyyshuutaus	EU-Declaration de Conformité EU-Dichiarazione di conformità EU-Conformiteitsverklaring EU-Deklaracja zgodności	FR - Directives - Normes harmonisées HU - Irányelvek - Harmonizált szabványok IT - Direttive - Norme armonizzate NL - Richtlijnen - Geharmoniseerde normen PL - Dyrektywy - Normy zharmonizowane EN 809:1998/AC:2010, EN ISO 12100:2010, EN 60335-1:2012/A13:2017 EN 55014-1:2017/A1:2020, EN 55014-2:1997/A2:2009, EN 60034-1:2010/AC:2010, EN 61000-3-2:2014, EN 61000-3-3:2013 EN 1127-1:2019	PT - Directiva - Normas harmonizadas RO - Directivă - Norme coroborate SK - Smernice - Harmonizované normy SV - Direktiv - Harmoniserade normer EN 60335-1:2012/A13:2017 EN 55014-1:2017/A1:2020, EN 55014-2:1997/A2:2009, EN 60034-1:2010/AC:2010, EN 61000-3-2:2014, EN 61000-3-3:2013 EN 1127-1:2019
DE - Wir erklären in alleiniger Verantwortung, dass das Produkt den aufgeführten Richtlinien entspricht. CS - Prohlášíme na svou výlučnou odpověďnost, že výrobek odpovídá jmenovaným směrnici. DA - Vi erklærer under ansvar at produktet i overensstemmelse med de retningslinjer. EN - We hereby declare, under our sole responsibility, that the product is in accordance with the specified Directives. FI - Mä vakuutamme omalla vastuullamme, että tuote täyttää ohjeita. FR - Nous déclarons sous notre propre responsabilité que le produit répond aux directives. HU - Kizárólagos felelősségünk tudatában kijelentjük, hogy ez a termék megfelel az Europai Unió fentnevezett irányelveinek. IT - Noi dichiariamo sotto la nostra esclusiva responsabilità che il prodotto è conforme alle direttive citate. NL - Wij verklaren geheel onder eigen verantwoordelijkheid dat het product voldoet aan de gestelde richtlijnen. PL - Z tegoż odpowiedzialności oświadczamy, że produkt odpowiada postanowieniom wymienionych dyrektyw. PT - Declaramos, sob nossa exclusiva responsabilidade, que o produto está em conformidade com as Diretivas especificadas. RO - Declaram pe proprie răspundere că produsul corespunde normelor prevăzute de directivele mai sus menționate. SK - Na výlučnú zodpovednosť vyhlásujeme, že výrobok spĺňa požiadavky uvedených smerníc. SV - Vi försäkrar att produkten på vårt ansvar är utförd enligt gällande riktlinjer.	DE - Bewillmächtigter für technische Dokumentation CS - Uprávněná osoba pro technickou dokumentaci DA - autoriseret person for teknisk dokumentation EN - Authorized person for technical documentation FI - Valtuutettu henkilö tekninen dokumentaatio FR - Personne autorisée à la documentation technique HU - Hivatalos személy műszaki dokumentáció IT - Persona abilitata per la documentazione tecnica NL - Bevoegd person voor technische documentatie PL - Pełnomocnik ds. dokumentacji technicznej PT - Pessoa autorizada para documentação técnica RO - Persoană autorizată pentru documentație tehnică SK - Uprávněná osoba pre technickú dokumentáciu SV - Aktiverad person för teknisk dokumentation JUNG PUMPEN - Stefan Sigges - Industriest. 4-6 - 33803 Steinhagen Steinshagen, 18-10-2022	DE - Weitere normative Dokumente CS - Jinými normativními dokumenty DA - Andre normative dokumenter EN - Other normative documents FI - Huiden normien FR - Autres documents normatifs HU - Egyéb szabványos dokumentumok NL - Aank andere documenten normatieve PL - Inne dokumenta normatywne NF - Outros documentos normativos RO - Alte acte normative SK - Iným záväznými dokumentmi SV - Vidare normerande dokument EN 60335-2-41:2003/A2:2010, TRGS 727	DE - Weitere normative Dokumente CS - Jinými normativními dokumenty DA - Andre normative dokumenter EN - Other normative documents FI - Huiden normien FR - Autres documents normatifs HU - Egyéb szabványos dokumentumok NL - Aank andere documenten normatieve PL - Inne dokumenta normatywne NF - Outros documentos normativos RO - Alte acte normative SK - Iným záväznými dokumentmi SV - Vidare normerande dokument EN 60335-2-41:2003/A2:2010, TRGS 727

Stefan Sigges, General Manager  
  
 Pascal Kolkebeck, Sales Manager



UKCA-Declaration of Conformity

Legislation - Designated Standards

- Supply of Machinery (Safety) Regulations 2008 (MD) EN 809:1988/AC:2010, EN ISO 12100:2010, EN 60335-1:2012/A13:2017
- The Restriction of the Use of Certain Hazardous Substances in Electrical and Electronic Equipment Regulations 2012 (RoHS) EN 55014-1:2017/A11:2020, EN 55014-2:1987/A2:2008, EN 60034-1:2010/AC:2010, EN 61000-3-2:2014, EN 61000-3-3:2015
- Electromagnetic Compatibility Regulations 2016 (EMC) EN 61000-3-2:2014, EN 61000-3-3:2015

Name and address of the manufacturer: JUNG PUMPEN GmbH - Industriestr. 4-6 - 33803 Steinhausen - Germany - www.jung-pumpen.de

We hereby declare, under our sole responsibility, that the product is in accordance with the specified Legislation.

- |                                 |                           |                                 |                            |
|---------------------------------|---------------------------|---------------------------------|----------------------------|
| Compl. 300 E (JP50686)          | Compl. 510/4 BW (JP50731) | Compl. 1010/4 BWE (JP50690)     | Compl. 108/2 ME (JP50689)  |
| Compl. 400 E (JP50188)          | Compl. 515/4 BW (JP50732) | Compl. 1010/4 BWE 15M (JP50720) | Compl. 108/2 M (JP50761)   |
| Compl. 400 R80 15M GB (JP50187) | Compl. 525/4 BW (JP50733) | Compl. 1010/4 BW (JP50721)      | Compl. 120/2 M (JP50762)   |
| Compl. 400 R80 4M GB (JP50782)  | Compl. 525/2 BW (JP50734) | Compl. 1015/4 BW (JP50722)      | Compl. 508/2 ME (JP50728)  |
| Compl. 400E R80 4M GB (JP50783) | Compl. 535/2 BW (JP50735) | Compl. 1025/4 BW (JP50723)      | Compl. 508/2 M (JP50729)   |
|                                 |                           | Compl. 1025/2 BW (JP50724)      | Compl. 520/2 M (JP50730)   |
|                                 |                           | Compl. 1035/2 BW (JP50725)      |                            |
|                                 |                           |                                 | Compl. 1008/2 ME (JP50692) |
|                                 |                           |                                 | Compl. 1008/2 M (JP50726)  |
|                                 |                           |                                 | Compl. 1020/2 M (JP50727)  |

Other normative documents:

EN 60335-2-41:2003/A2:2010

Authorized person for technical documentation  
JUNG PUMPEN - Stefan Sirges - Industriestr. 4-6 - 33804 Steinhausen  
Steinhausen, 18-04-2023

  
Stefan Sirges, General Manager

  
i.V.  
Pascal Kollbeck, Sales Manager

Technische Daten - Technical data - Caractéristiques techniques- Technische Gegevens - Dati tecnici - Dane techniczne - Technické údaje - Technické údaje - Műszaki adatok - Date tehnice - 技术指标

compli 100

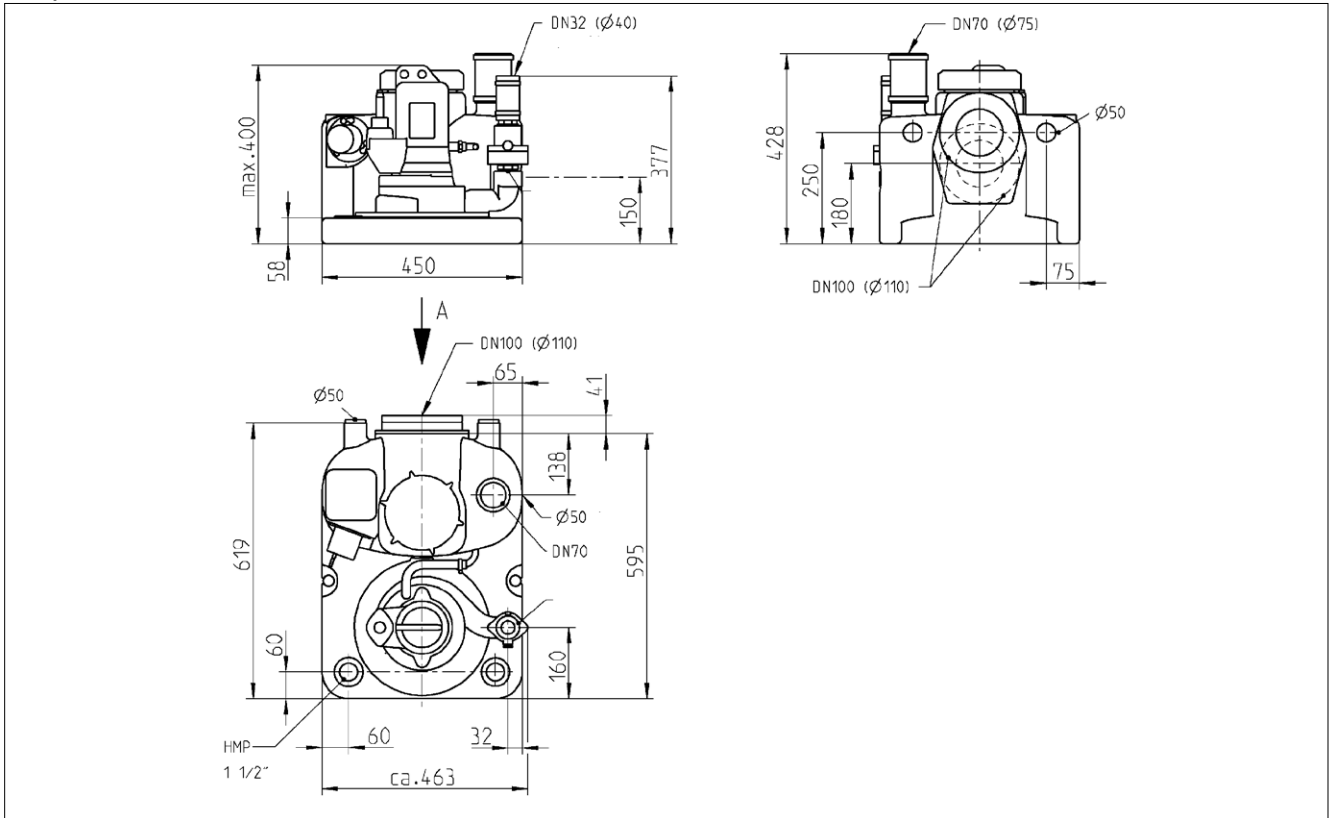

Compli 300

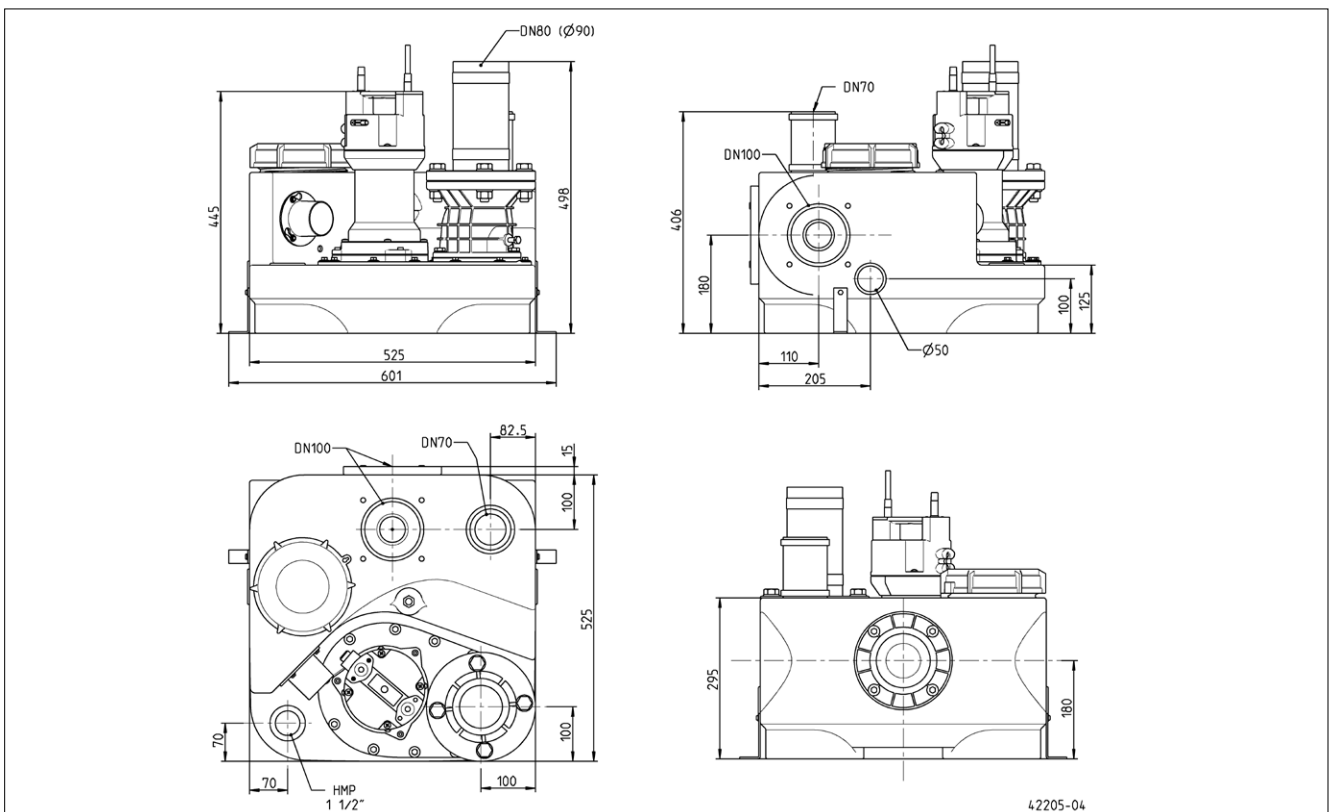

42205-04

**compli 400**

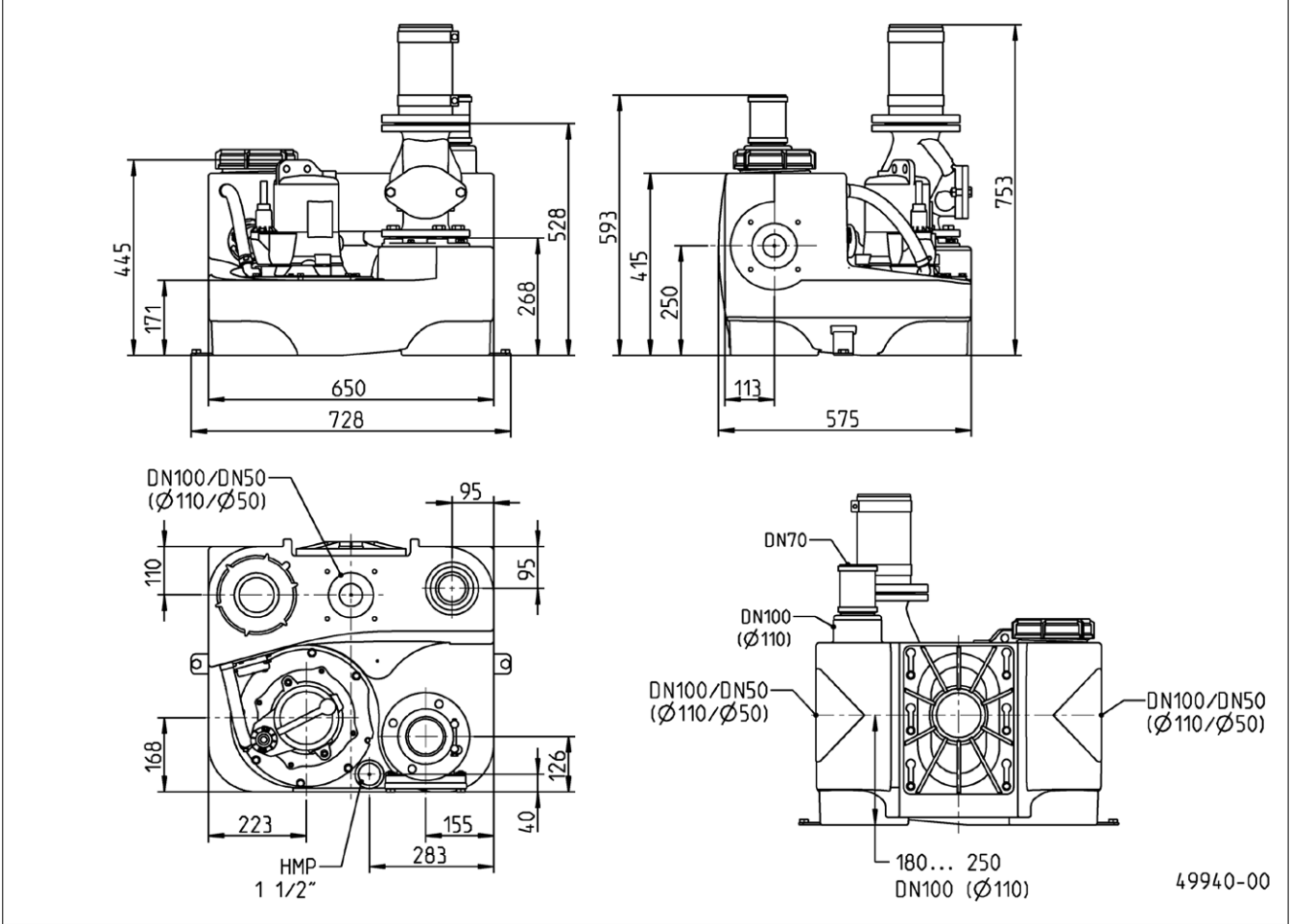

**compli 500**

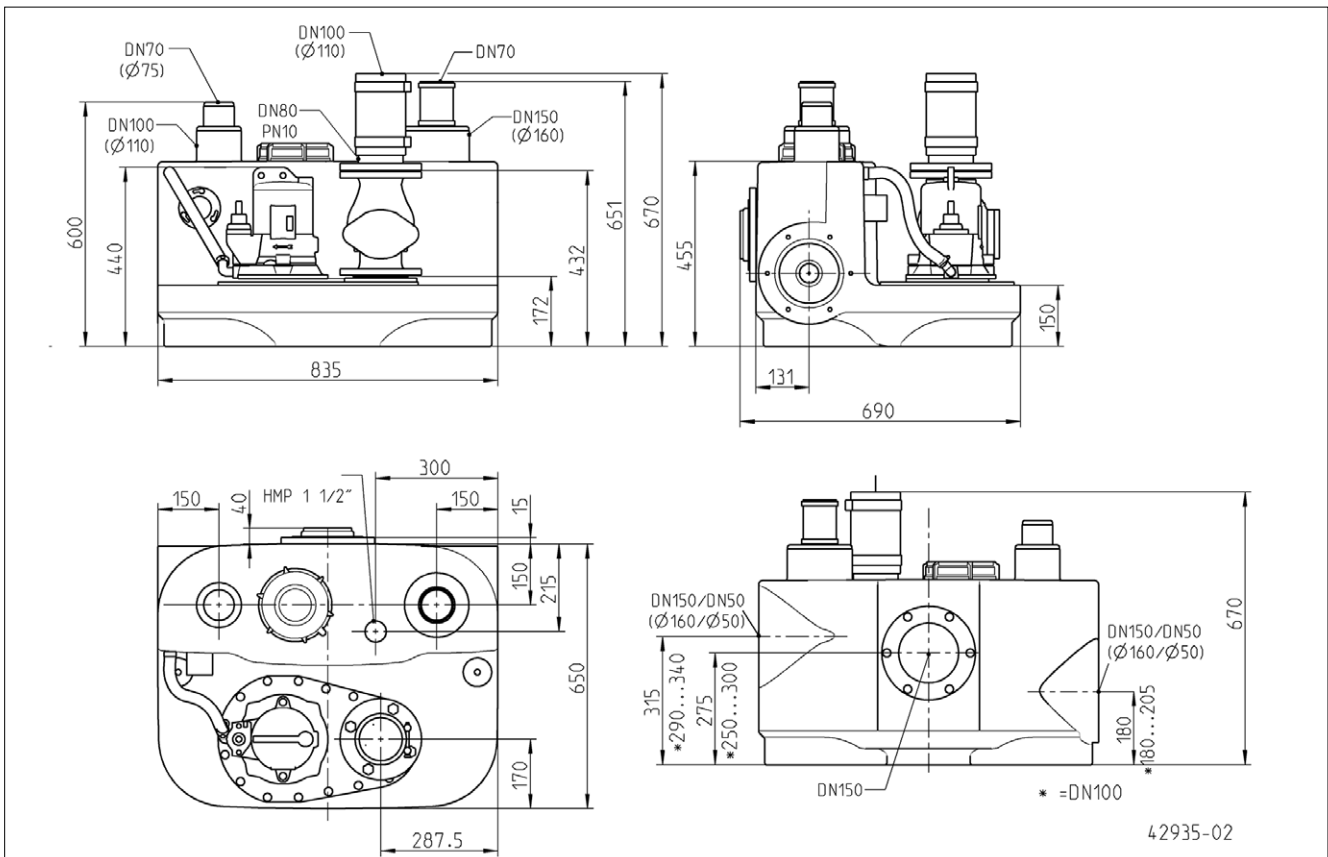

**compli 500 M**

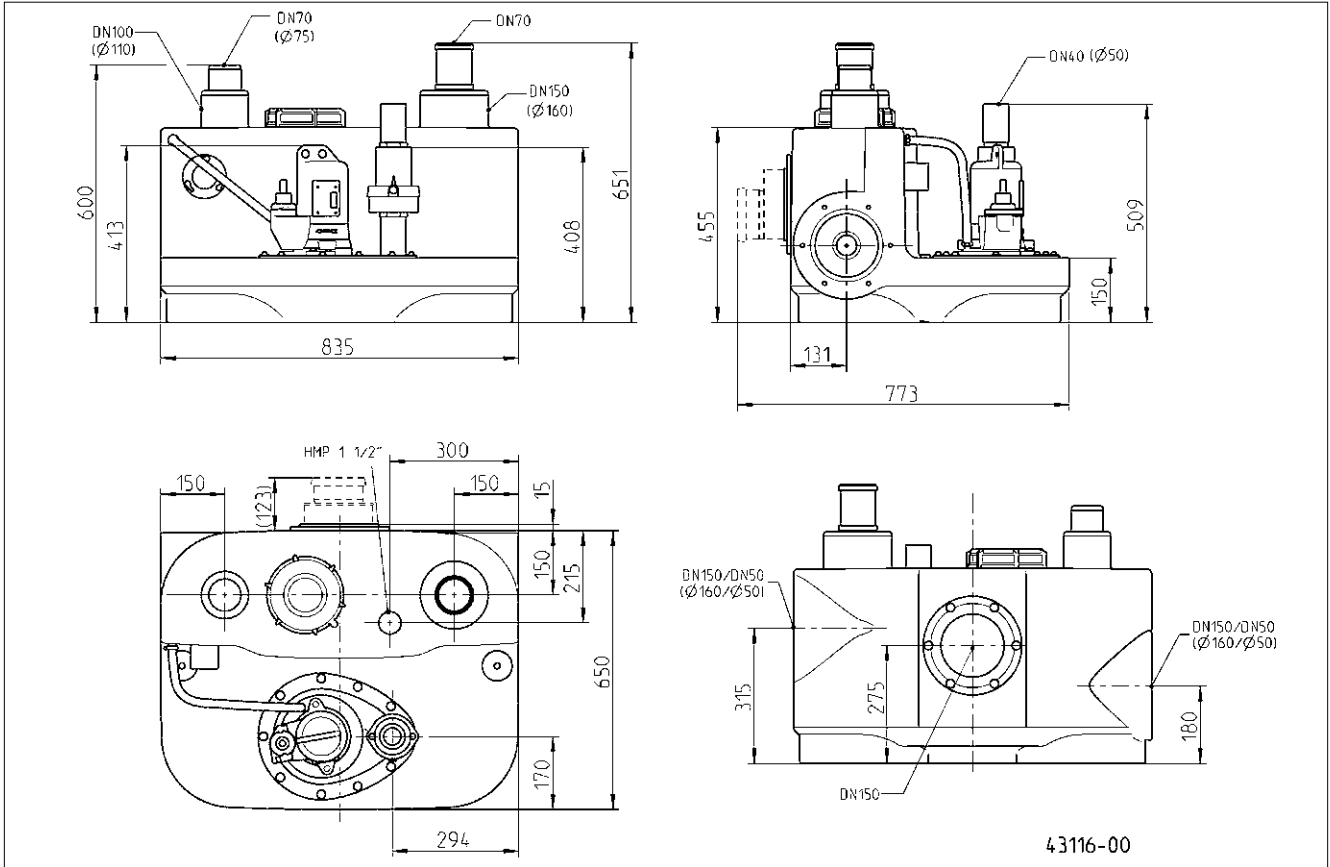

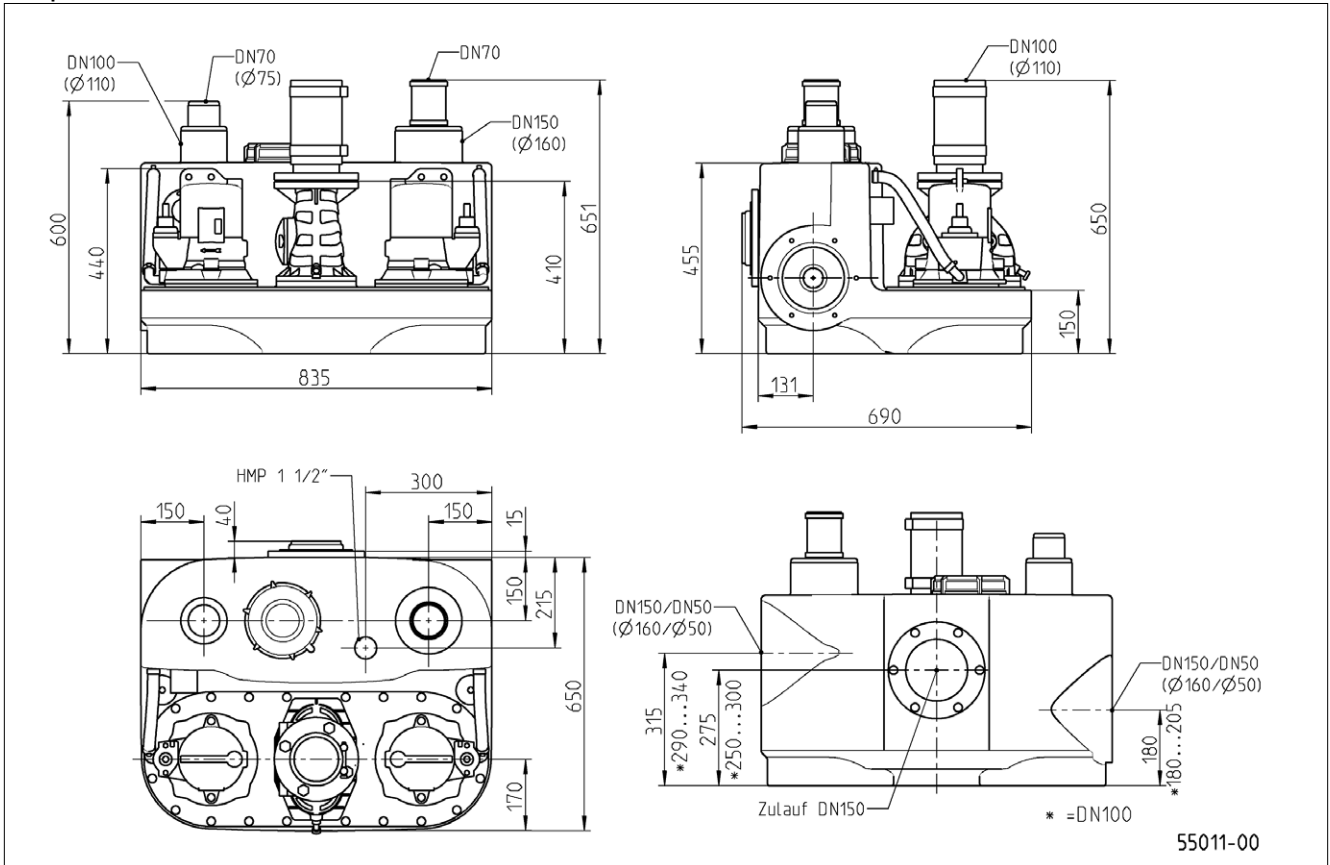

**compli 1000**

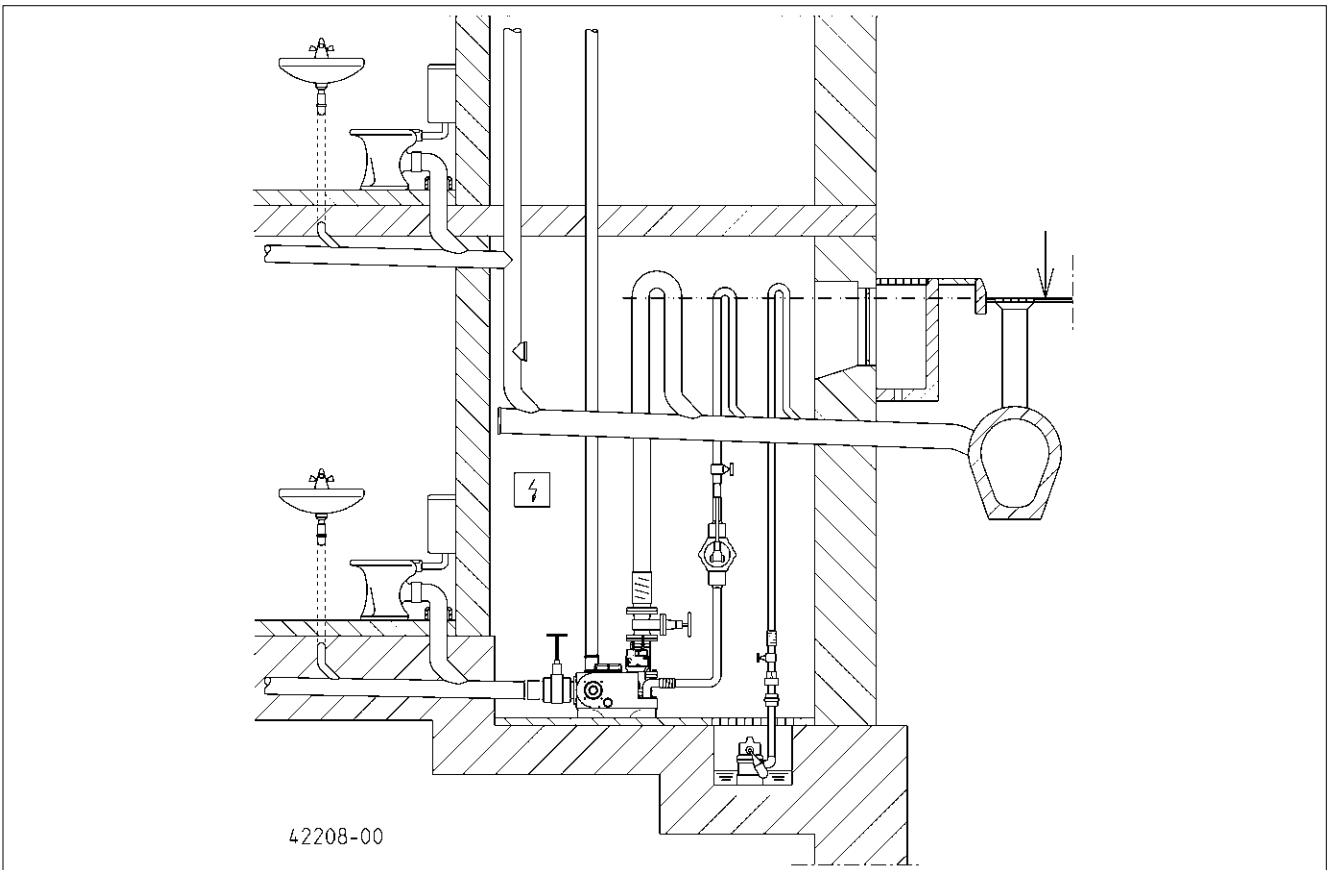
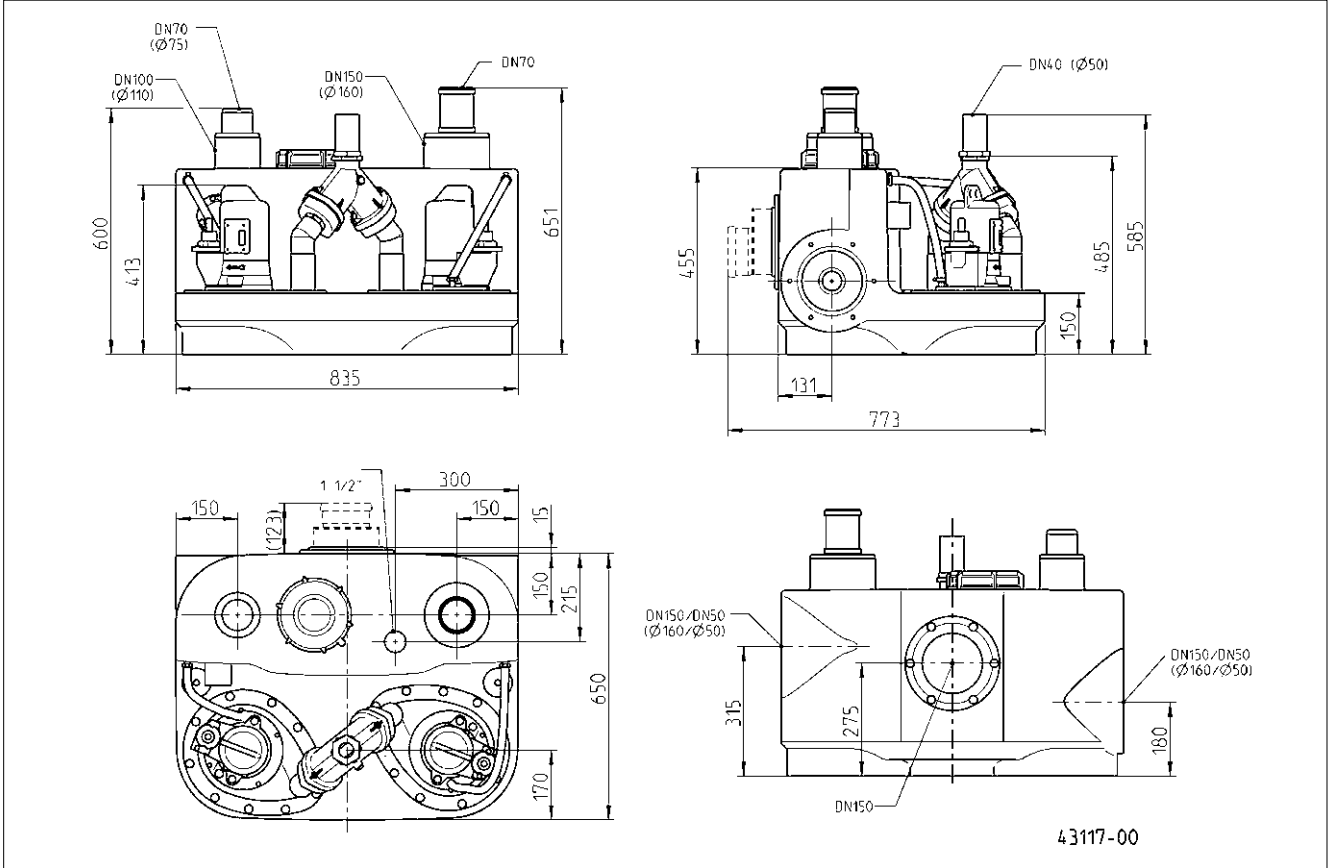

compli 1000 M



		<b>... 300 E</b>	<b>... 400 E</b>	<b>... 1010 BWE</b>	<b>... 400</b>
	[kg]	29	56	118	56
	PN 10	DN 80	DN 80	DN 80	DN 80
	[mm]	50	70	70	70
S3* / Tmax	[°C]	10 % / 40	25 % / 40	25 % / 40	30 % / 40
P1	[kW]	1,37	1,55	1,55	1,25
P2	[kW]	0,98	1,10	1,10	0,87
U	[V]	1/N/PE ~230	1/N/PE ~230	1/N/PE ~230	3/N/PE ~400
f	[Hz]	50	50	50	50
I	[A]	6,0	7,1	7,1	2,2
n	[min <sup>-1</sup> ]	2700	1428	1428	1390
			AD 69 ECR	BD 610 ECR	AD 00 R

		<b>... 510/4 BW</b>	<b>... 515/4 BW</b>	<b>... 525/4 BW</b>	<b>... 425/2 BW</b>	<b>... 435/2 BW</b>
		<b>... 1010/4 BW</b>	<b>... 1015/4 BW</b>	<b>... 1025/4 BW</b>	<b>... 525/2 BW</b>	<b>... 535/2 BW</b>
		<b>... 1010/4 BW</b>	<b>... 1015/4 BW</b>	<b>... 1025/4 BW</b>	<b>... 1025/2 BW</b>	<b>... 1035/2 BW</b>
	[kg]	79/128	79/128	79/128	81/86/125	84/89/132
	PN 10	DN 80	DN 80	DN 80	DN 80	DN 80
	[mm]	70	70	70	70	70
S3* / Tmax	[°C]	30 % / 40	30 % / 40	15 % / 40	25 % / 40	25 % / 40
P1	[kW]	1,25	2,2	3,0	3,3	4,8
P2	[kW]	0,87	1,7	2,2	2,6	4,0
U	[V]	3/N/PE ~400	3/N/PE ~400	3/N/PE ~400	3/N/PE ~400	3/N/PE ~400
f	[Hz]	50	50	50	50	50
I	[A]	2,2	3,9	5,1	5,4	7,8
n	[min <sup>-1</sup> ]	1390	1405	1363	2807	2857
		AD 00 R / BD 25 R	AD 25 R / BD 25 R	AD 46 R / BD 46 R	AD 46 R / BD 46 R	AD 610 R / BD 610 R

		<b>... 108/2 ME</b>	<b>... 108/2 M</b>	<b>... 120/2 M</b>
		<b>... 508/2 ME</b>	<b>... 508/2 M</b>	<b>... 520/2 M</b>
		<b>... 1008/2 ME</b>	<b>... 1008/2 M</b>	<b>... 1020/2 M</b>
	[kg]	42/50/77	41/49/75	43/51/79
	PN 10	DN 32/40/40	DN 32/40/40	DN 32/40/40
	[mm]	7	7	7
S3* / Tmax	[°C]	10 % / 40	35 % / 40	25 % / 40
P1	[kW]	1,70	1,65	2,30
P2	[kW]	1,14	1,24	1,85
U	[V]	1/N/PE ~230	3/N/PE ~400	3/N/PE ~400
f	[Hz]	50	50	50
I	[A]	7,5	2,8	3,9
n	[min <sup>-1</sup> ]	2584	2674	2860
		AD 08/2 MER	AD 00 R / BD 00 R	AD 46 R / BD 46 R

\* Example for 40%: 4 min. operation and 6 min. rest (Cycle duration 10 min.);  
 Esempio: 40%: 4 min. di funzionamento + 6 min. di pausa (durata del ciclo 10 min.)  
 Příklad 40%: 4 min. provoz a 6 min. přestávka (trvání pracovního cyklu 10 min.)  
 4 perc üzem és 6 perc szünet (ciklusidő 10 perc)

Exemple: 40% = 4 min de service et 6 min de pause (Durée du jeu 10 min)  
 Przykładowo 40%: 4 min pracy i 6 min przerwy (Czas cyklu 10 min);  
 Příklad 40%: 4 min prevádzka a 6 min prestávka (doba trvania cyklu 10 min);  
 Exemplu 40%: 4 min funcționare și 6 min pauză (timp aproximativ 10 min)

Leistung - Performance - Puissances - Capaciteit - Prestazioni - Wydajności i moce -  
 Výkony - Výkony - Teljesítmény - Capacități - 性能参数

H [m]	1	2	3	4	5	6	7	8	9	10	11	12	13	14	15	16	17	
compl 300 E	30	29	28	24	22	19	15											Q [m³/h]
compl 400 E	48	40	33	27	20	10												
compl 1010 BWE	48	40	33	27	20	10												
compl 400	48	40	33	27	20	10												
... 10/4 BW	48	40	33	27	20	10												
... 15/4 BW	69	62	56	49	42	36	27	19										
... 25/4 BW					56	49	42	32	22	13								
... 25/2 BW	69	64	58	52	47	42	37	33	28	23	20	14	8	1				
... 35/2 BW	85	80	75	71	66	62	57	54	50	47	44	39	36	33	30	26	21	
... 08/2 ME		17		16		14		12		9		7		4				
... 08/2 M		17		16		14		12		9		7		4				
... 20/2 M								16		14		12		10			8	

compl 300 E

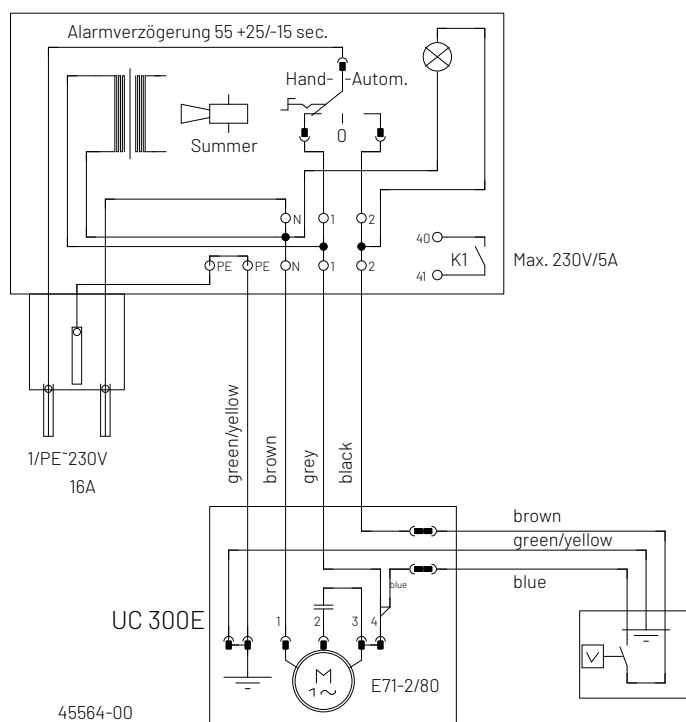



# AD 69 ECR - Compli 400 E

Einzelanlage - Single unit - Unité de commande Poste simple - Regelaar van een enkelvoudige installatie - Comando singolo - Sterownik instalacji jednopompowej - Řídicí jednotka jednoduché zařízení - Riadenie samostatného zariadenia - Egyedi berendezés vezérlője - Sistem de comandă instalație individuală - 单泵系统

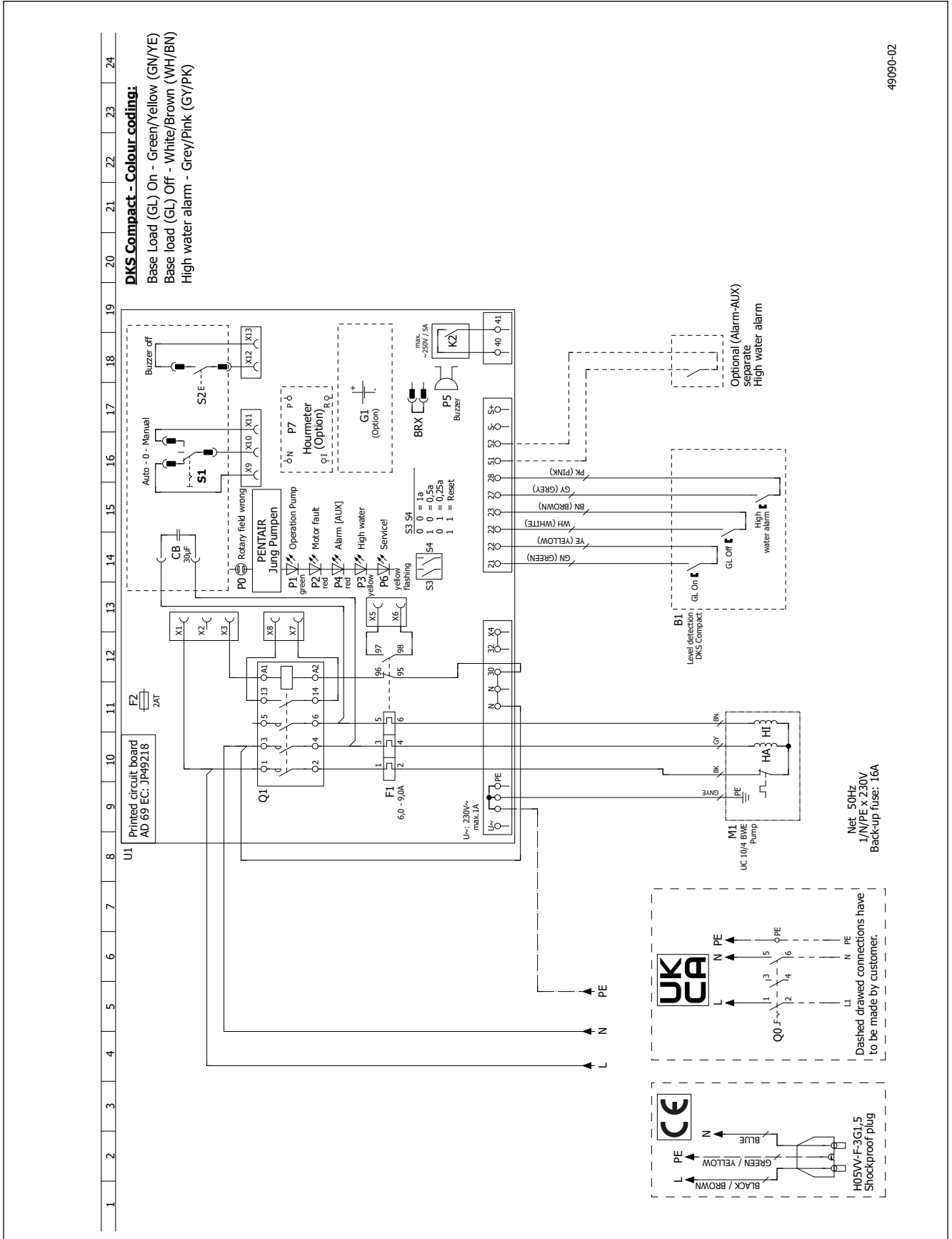

49090-02

# AD 69 MECR - Compli 08/2

Einzelanlage - Single unit - Unité de commande Poste simple - Regelaar van een enkelvoudige installatie - Comando singolo -Stewownik instalacji jednopompowej - Řídicí jednotka jednoduché zařízení - Riadenie samostatného zariadenia - Egyedi berendezés vezérlője - Sistem de comandă instalație individuală - 单泵系统

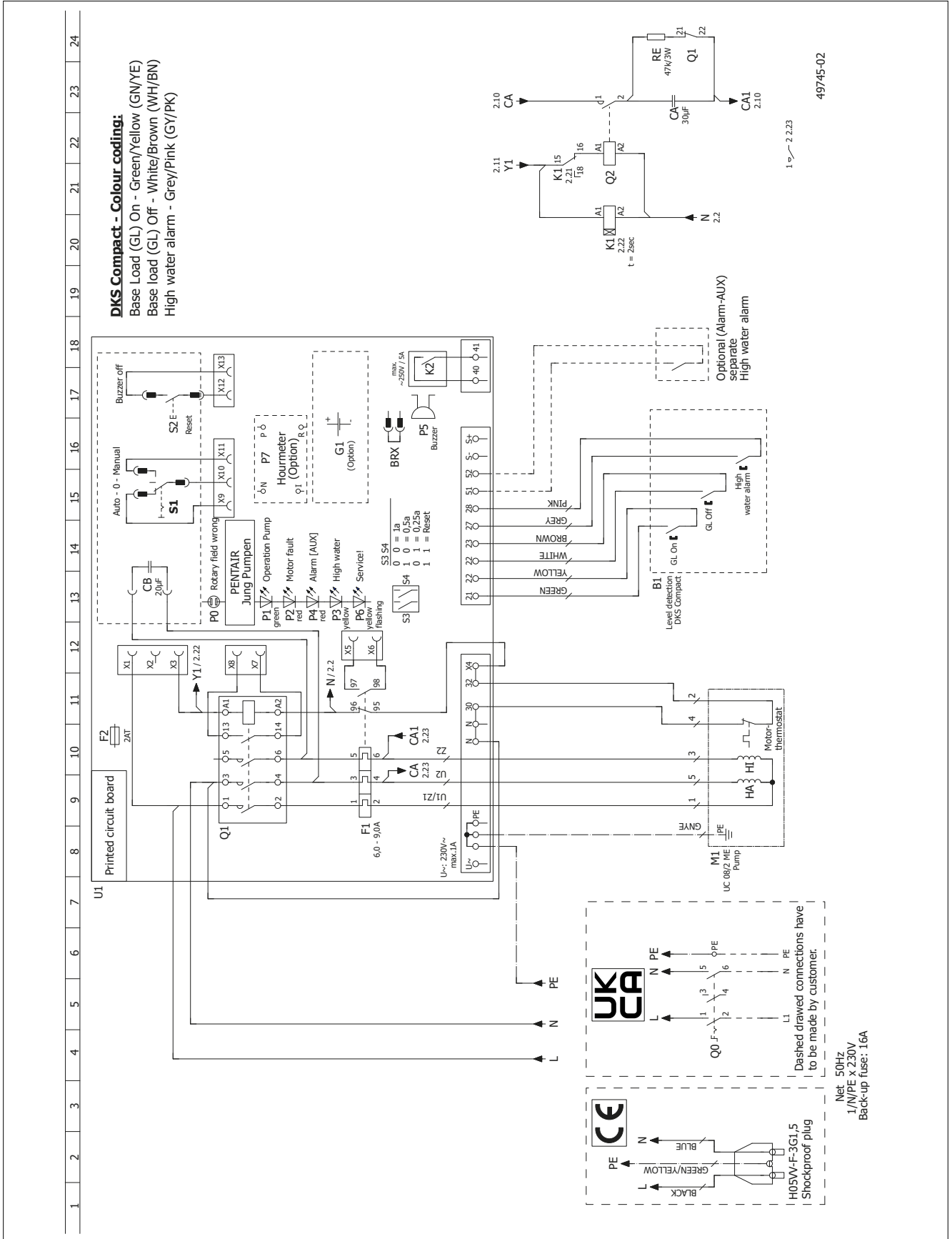

# AD ... R

Einzelanlage - Single unit - Unité de commande Poste simple - Comando singolo - Regelaar van een enkelvoudige installatie  
 - Sterownik instalacji jednopompowej - Řídicí jednotka jednoduché zařízení - Riadenie samostatného zariadenia - Egyedi  
 berendezés vezérlője - Sistem de comandă instalație individuală - 单泵系统

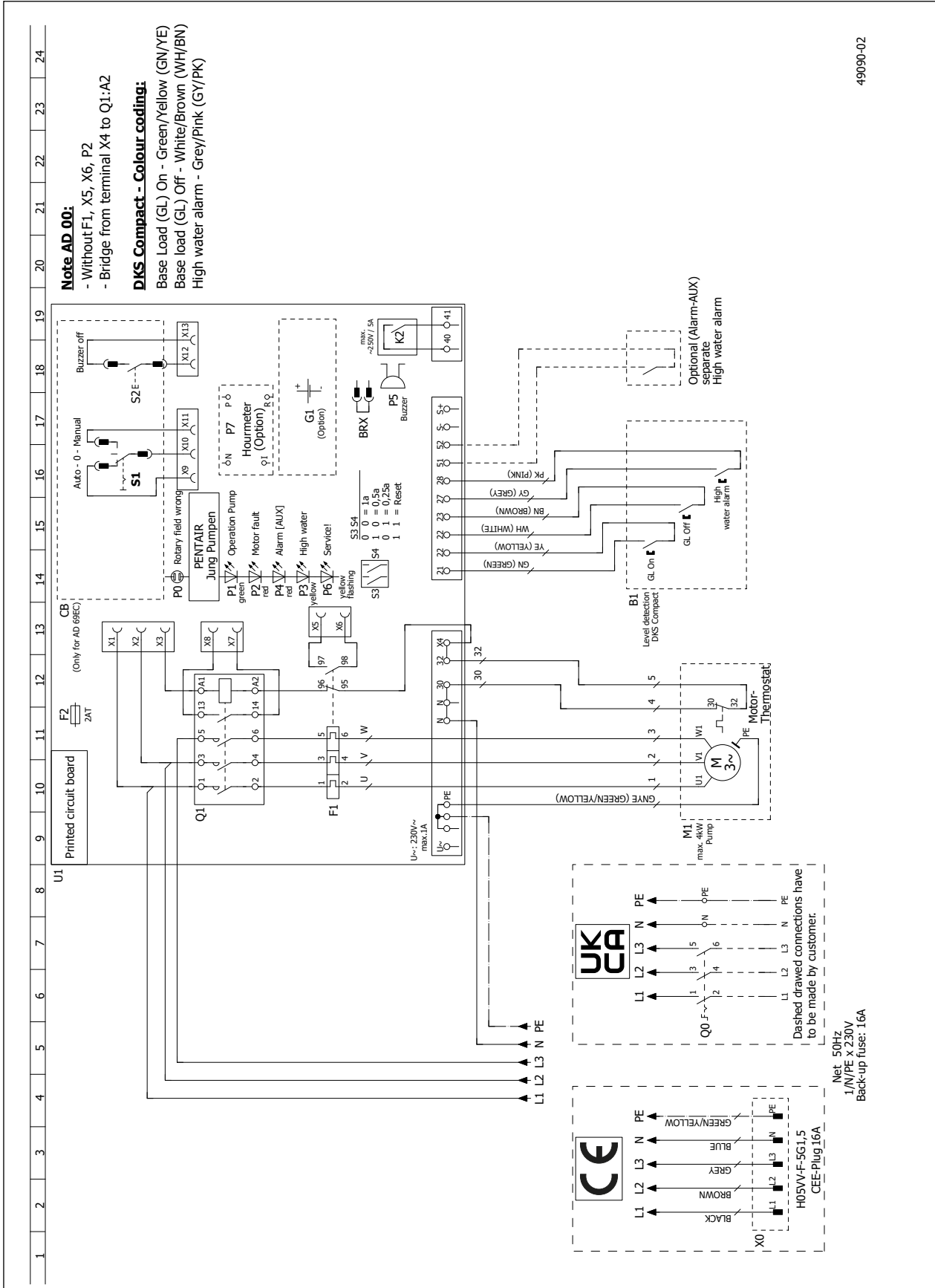

49090-02

# BD 610 ME CR - compli 1008/2 ME

Doppelanlage - Duplex unit - Comando doppio Unité de commande Poste double - Regelaar van een dubbele installatie - Comando doppio - Sterownik instalacji dwupompowej - Řídicí jednotka dvojité zařízení - Riadenie dvojitého zariadenia - Kettős berendezés - Sistem de comandă instalatie dublă - 双泵系统

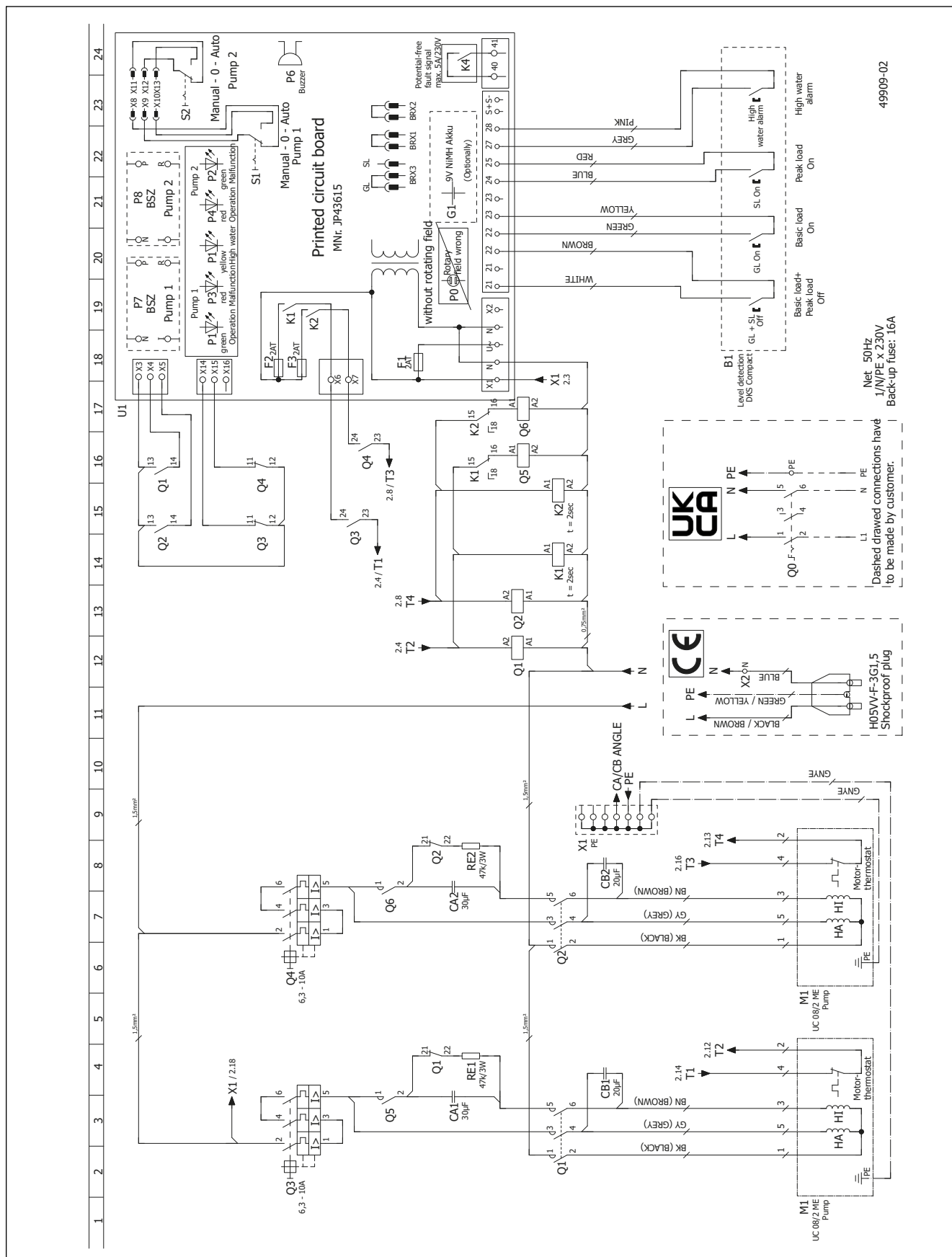

# BD 610 ECR - Compli 1010/4 BWE

Doppelanlage - Duplex unit - Unité de commande Poste double - Comando doppio - Regelaar van een dubbele installatie - Sterownik instalacji dwupompowej - Řídicí jednotka dvojitě zařízení - Riadenie dvojitého zariadenia - Kettős berendezés - Sistem de comandă instalatie dublă - 双泵系统

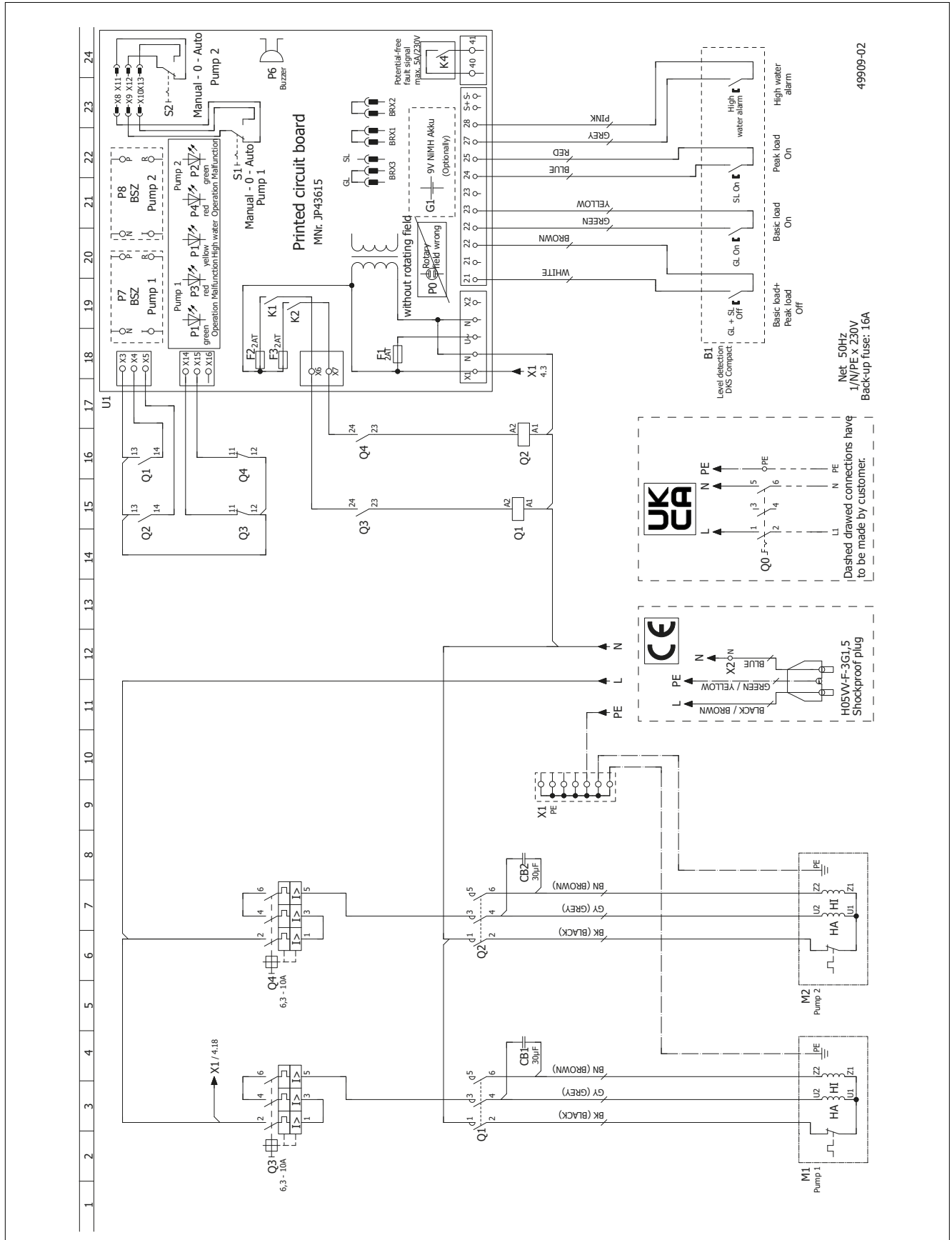

# BD ... R

Doppelanlage - Duplex unit - Unité de commande Poste double - Comando doppio - Regelaar van een dubbele installatie - Sterownik instalacji dwupompowej - Řídicí jednotka dvojitě zařízení - Riadenie dvojitého zariadenia - Kettős berendezés - Sistem de comandă instalatie dublă - 双泵系统

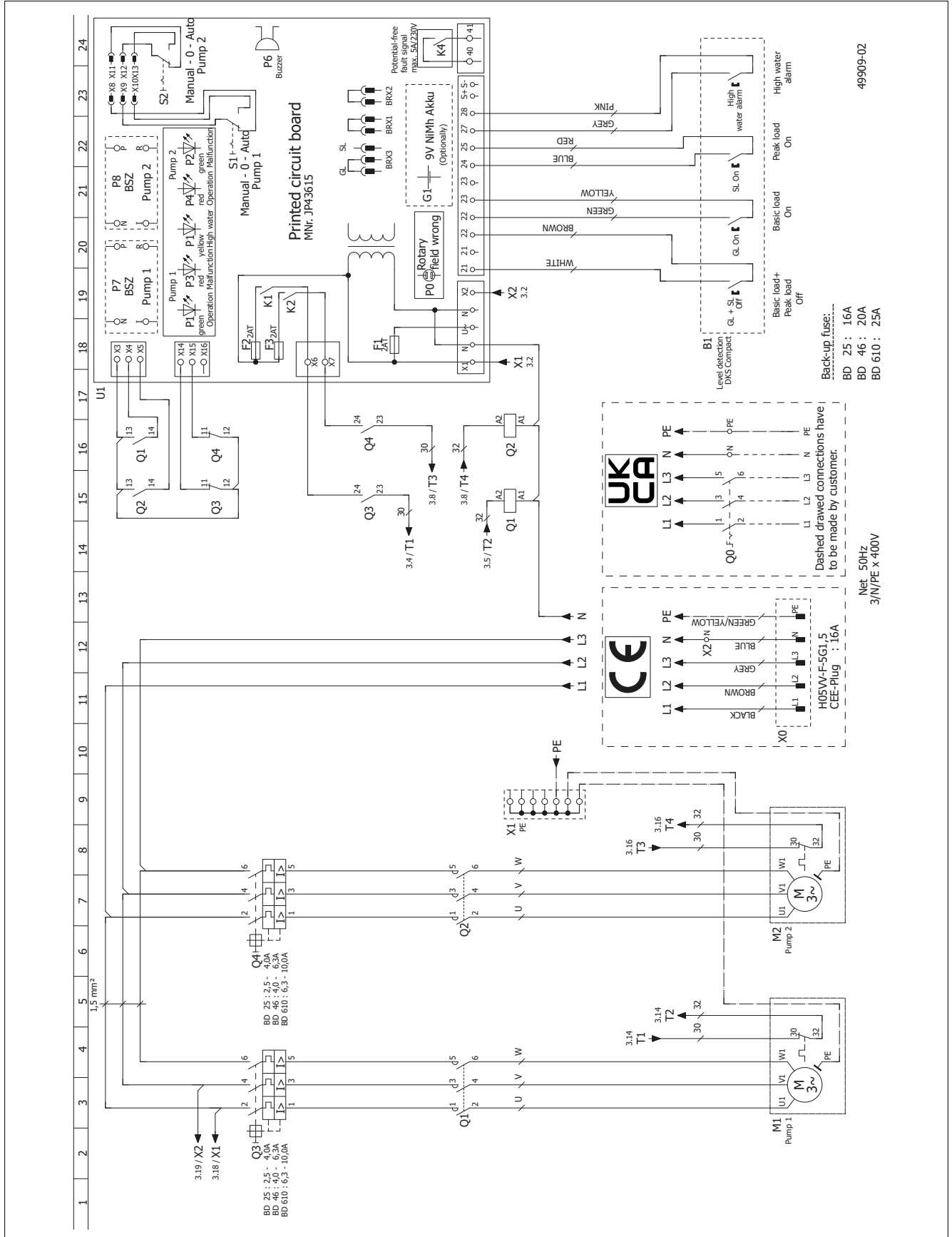

**COMPLI 300 E**

Ersatzteile - Spare parts - Pièces de rechange - Reserveonderdelen - Parti di ricambio - Reservedele - Reservdelar  
 Varaosat - Części zamienne - Náhradní díly - Alkatrészek - Piese de schimb - Запасные части - 备件



①	Motoreinheit	Motor unit	JP47288
②	Elast. Verbindung	Elastic connector	JP42792
③	Flansch	Flange	JP42793
④	Rückschlagventil	Reflux valve	JP42794
⑤	Gummiklappe	Valve flap	JP46841
⑥	Basisplatte	Basis plate	JP42797
⑦	Dichtband	Sealing tape	JP47966
⑧	Überschiebmuffe	Collar	JP47287
⑨	Wartungsdeckel	Service lid	JP42798
⑩	Klemmflansch	Clamping flange	JP42795
⑪	Pumpenlüftung	Pump ventilation	JP42799
⑫	Steckdichtung	Plug in seal	JP45099
⑬	Behälter	Tank	JP44749
⑭	Auftriebssicherung	Anti floating	JP42796
⑮	Schraubensatz	Screw set	JP42800
⑯	Dichtungssatz	Seal set	JP42801

**PENTAIR JUNG PUMPEN**  
**MOTOR COMPLI 300 E**



①	Steuerung	Control unit	JP42802
②	Leitung	Cable	JP50330
③	Niveauschaltung	Level control unit	JP50331
④	Kondensator	Capacitor	JP46016
⑤	Haube	Top Cover	JP46019
⑥	Schwimmer	Float	JP42771
⑦	Rotorwelle	Rotor shaft	JP47289
⑧	Lagersatz	Bearing set	JP46042
⑨	Motorabdichtung	Motor seals	JP46728
⑩	Stator + Gehäuse	Stator + Housing	JP46029
⑪	Dichtungssatz	Seal set	JP42810
⑫	Schraubensatz	Screw set	JP42809
⑬	Lauftrad	Impeller	JP46053
⑭	Lagerschild	Bearing housing	JP42806



**COMPLI 400**

Ersatzteile - Spare parts - Pièces de rechange - Reserveonderdelen - Parti di ricambio - Reservedele - Reservdelar  
 Varaosat - Części zamienne - Náhradní díly - Alkatrészek - Piese de schimb - Запасные части - 备件



①	Pumpe Compli 400 Compli 400, 15M Compli 400 E Compli 400 E, 15M	Pump	<b>JP50469</b> <b>JP50162</b> <b>JP50470</b> <b>JP50584</b>
②	Adapter DN100/80		<b>JP50478</b>
③	Elast. Verbindung	Elastic connector	<b>JP43705</b>
④	Steuerung AD 00R (Compli 400) AD 69ECR (Compli 400 E)	Control unit	<b>JP50491</b> <b>JP50495</b>
⑤	Pumpenaufnahme	Mounting ring pump	<b>JP50477</b>
⑥	Flansch	Flange	<b>JP43706</b>
⑦	Steuerungsplatine PCBA AD 00 (Compli 400) PCBA AD 69EC (Compli 400 E)	Control board	<b>JP50497</b> <b>JP50501</b>
⑧	Niveauerfassung	Level control	<b>JP50467</b>
⑨	Rückschlagklappe	Reflux valve	<b>JP43707</b>
⑩	Zulauf	Inlet	<b>JP50472</b>
⑪	Montageset Pumpe	Pump assembly kid	<b>JP49001</b>
⑫	Dichtung Niveauerf.	Spare seal level control	<b>JP50479</b>
⑬	Wartungsdeckel	Service lid	<b>JP42798</b>
⑭	Montagering RSK	Mounting ring RV	<b>JP50476</b>
⑮	Dichtungen Drucks.	Seals discharge	<b>JP50481</b>
⑯	Dichtungen Hydr.	Seals hydraulic	<b>JP50480</b>
⑰	Überschiebmuffe	Collar	<b>JP47287</b>
⑱	Pumpenlüftung	Pump ventilation	<b>JP43710</b>
⑲	Steckdichtung	Plug in seal	<b>JP45099</b>
⑳	Auftriebssichg.	Anti floating	<b>JP50473</b>
㉑	Behälter (inkl. Pos 10)	Tank (incl. pos. 10)	<b>JP50474</b>

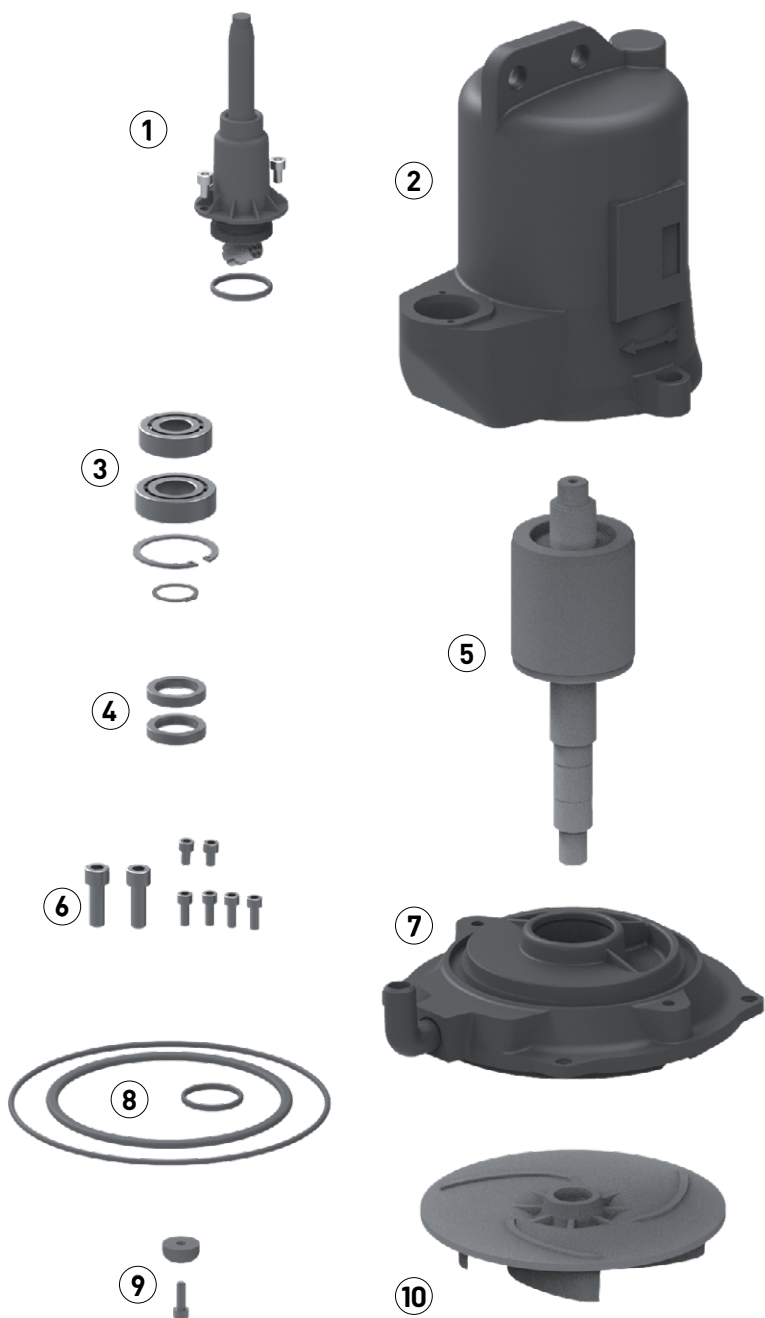

① Leitung	Cable	
compli 400	10/4 BW	<b>JP50485</b>
	10/4 BW, 15 m	<b>JP50161</b>
compli 400 E	10/4 BWE, 4m	<b>JP50486</b>
	10/4 BWE, 15m	<b>JP50487</b>
② Stator + Gehäuse	Stator + Housing	
compli 400		<b>JP50488</b>
compli 400 E		<b>JP50448</b>
③ Lagersatz	Bearing set	<b>JP46724</b>
④ Motorabdichtung	Motor seals	<b>JP46806</b>
⑤ Rotorwelle	Rotor shaft	
compli 400		<b>JP46761</b>
compli 400 E		<b>JP46801</b>
⑥ Schraubensatz	Screw set	<b>JP50450</b>
⑦ Lagerschild	Bearing housing	<b>JP43720</b>
⑧ Dichtungssatz	Seal set	<b>JP50449</b>
⑨ Laufradschraube	Impeller screw	<b>JP46803</b>
⑩ Laufrad	Impeller	
	UC 10/4	<b>JP47290</b>
	UC 15/4	<b>JP50320</b>
	UC 25/4	<b>JP50321</b>

Ersatzteile - Spare parts - Pièces de rechange - Reserveonderdelen - Parti di ricambio - Reservedele - Reservdelar  
 Varaosat - Części zamienne - Náhradní díly - Alkatrészek - Piese de schimb - Запасные части - 备件



①	Niveauerfassung	Level control	<b>JP50467</b>
②	Dichtung Niveauerfassung	Seal level control	<b>JP50479</b>
③	Adapter	Adapter	<b>JP50478</b>
④	Steuerung	Control unit	
	AD 00R (Compli 510/4)		<b>JP50491</b>
	AD 25R (510/4, 515/4)		<b>JP50492</b>
	AD 46R (525/2, 525/4)		<b>JP50493</b>
	AD 610R (535/2)		<b>JP50494</b>
⑤	Elast. Verbindung	Elastic connector	<b>JP43705</b>
⑥	Flansch	Flange	<b>JP43706</b>
⑦	Steuerungsplatine	Control board	<b>JP50491</b>
	PCBA AD 25 (510/4, 515/4)		<b>JP50498</b>
	PCBA AD 46 (525/2, 525/4)		<b>JP50499</b>
	PCBA AD 610 (535/2)		<b>JP50500</b>
⑧	Pumpe	Pump	
	...10/4		<b>JP50469</b>
	...15/4		<b>JP48824</b>
	...25/4		<b>JP48825</b>
	...25/2		<b>JP48826</b>
	...35/2		<b>JP48827</b>
	...10/4, 15M		<b>JP50162</b>
	...15/4, 15M		<b>JP50163</b>
	...25/4, 15M		<b>JP50164</b>
⑨	Rückschlagklappe	Reflux valve	<b>JP43707</b>
⑩	Reduzierstück DN 150/DN 100	Reducer DN 150/DN 100	<b>JP48871</b>
⑪	Basisplatte	Base plate	<b>JP43711</b>
⑫	Klemmflansch	Clamping flange	<b>JP43713</b>
⑬	Dichtband	Sealing tape	<b>JP47966</b>
⑭	Pumpenlüftung	Pump ventilation	<b>JP43710</b>
⑮	Wartungsdeckel	Service lid	<b>JP42798</b>
⑯	Steckdichtung D50xD59	Plug-in connection D50xD59	<b>JP45099</b>
⑰	Überschiebmuffe	Collar	<b>JP47287</b>
⑱	Auftriebssicherung	Anti floating	<b>JP43709</b>
⑲	Behälter	Tank	<b>JP44860</b>



①	Niveauerfassung	Level control	
	4 m		<b>JP50467</b>
	15 m		<b>JP50468</b>
②	Dichtung Niveauerfassung	Seal level control	<b>JP50479</b>
③	Adapter	Adaper	<b>JP50478</b>
④	Steuerung	Control unit	
	BD 610ECR (1010/4 BWE)		<b>JP50504</b>
	BD 25R (1010/4, 1015/4)		<b>JP50505</b>
	BD 46R (1025/4, 1025/2)		<b>JP50506</b>
	BD 610R (1035/2)		<b>JP50507</b>
⑤	Elastische Verbindung	Elastic connector	<b>JP43705</b>
⑥	Flansch	Flange	<b>JP43706</b>
⑦	Steuerungsplatine	Control board	<b>JP47304</b>
	Leistungsschütz	Contactur	<b>JP47671</b>
	230V DIL EM-10 4 KW	230V DIL EM-10 4 KW	
⑧	Pumpe	Pump	
	...10/4 BWE, 4 m		<b>JP50470</b>
	...10/4 BWE, 15 m		<b>JP50584</b>
	...10/4		<b>JP50469</b>
	...15/4		<b>JP48824</b>
	...25/4		<b>JP48825</b>
	...25/2		<b>JP48826</b>
	...35/2		<b>JP48827</b>
	...10/4, 15M		<b>JP50162</b>
	...15/4, 15M		<b>JP50163</b>
	...25/4, 15M		<b>JP50164</b>
⑨	Rückschlagklappe	Reflux valve	<b>JP50566</b>
⑩	Reduzierstück DN 150/DN 100	Reducer DN 150/DN 100	<b>JP48871</b>
⑪	Doppelklappe	Double flap	<b>JP46812</b>
⑫	Klemmflansch	Clamping flange	<b>JP43713</b>
⑬	Basisplatte	Base plate	<b>JP43714</b>
⑭	Pumpenlüftung	Pump ventilation	<b>JP43710</b>
⑮	Dichtband	Sealing tape	<b>JP47966</b>
⑯	Wartungsdeckel	Service lid	<b>JP42798</b>
⑰	Steckdichtung D50xD59	Plug-in connection D50xD59	<b>JP45099</b>
⑱	Überschiebmuffe	Collar	<b>JP47287</b>
⑲	Auftriebssicherung	Anti floating	<b>JP43709</b>
⑳	Behälter	Tank	<b>JP44861</b>

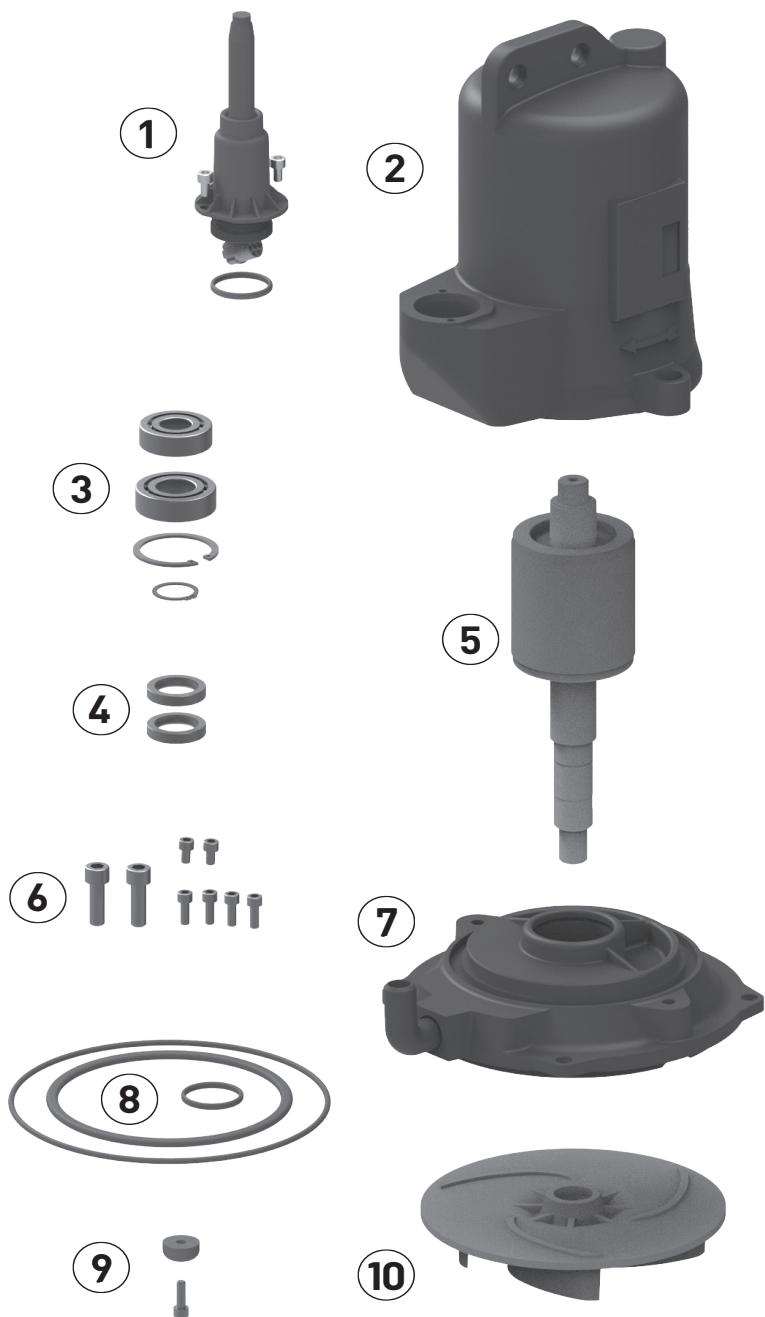

①	Leitung	Cable	
	10/4, 15/4, 25/4, 4 m		<b>JP50485</b>
	10/4, 15/4, 25/4, 15 m		<b>JP50161</b>
	1010/4 BWE, 4 m		<b>JP50486</b>
	1010/4 BWE, 15 m		<b>JP50487</b>
②	Stator + Gehäuse	Stator + Housing	
	10/4		<b>JP50488</b>
	15/4, 25/4		<b>JP50447</b>
	1010/4 BWE		<b>JP50448</b>
③	Lagersatz	Bearing set	<b>JP46724</b>
④	Motorabdichtung	Motor seals	<b>JP46806</b>
⑤	Rotorwelle	Rotor shaft	
	10/4		<b>JP46761</b>
	15/4, 25/4		<b>JP50322</b>
	1010/4 BWE		<b>JP46801</b>
⑥	Schraubensatz	Screw set	<b>JP50450</b>
⑦	Lagerschild	Bearing housing	<b>JP43720</b>
⑧	Dichtungssatz	Seal set	<b>JP50449</b>
⑨	Laufadschraube	Impeller screw	<b>JP46803</b>
⑩	Laufad	Impeller	
	10/4		<b>JP47290</b>
	15/4		<b>JP50320</b>
	25/4		<b>JP50321</b>
	1010/4 BWE		<b>JP47290</b>

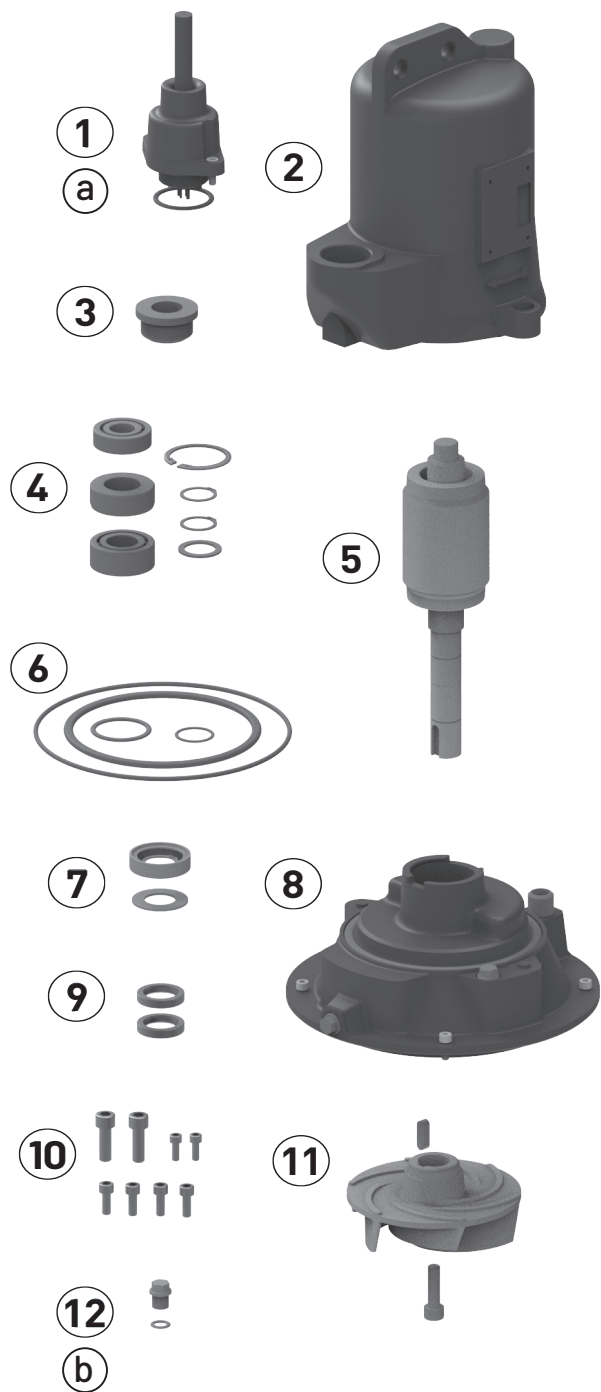

①	Leitung	Cable	<b>JP43717</b>
②	Stator + Gehäuse	Stator + Housing	
	25/2		<b>JP44008</b>
	35/2		<b>JP46211</b>
③	Gleitringdichtung	Mechanical seal	<b>JP46567</b>
④	Lagersatz	Bearing set	<b>JP46214</b>
⑤	Rotorwelle	Rotor shaft	
	25/2		<b>JP48339</b>
	35/2		<b>JP48340</b>
⑥	Dichtungssatz	Seal set	<b>JP46807</b>
⑦	Wellenabdeckung	Shaft cover	<b>JP47043</b>
⑧	Lagerschild	Bearing housing	<b>JP43726</b>
⑨	Motorabdichtung	Motor seals	<b>JP46806</b>
⑩	Schraubensatz	Screw set	<b>JP47291</b>
⑪	Lauftrad	Impeller	
	25/2		<b>JP48359</b>
	35/2		<b>JP48360</b>
⑫	Ölschraube	Oil screw	<b>JP46046</b>

a	10x O-Ring 38x3,5	<b>JP48109</b>
b	10x O-Ring 10x2,5	<b>JP48088</b>

## COMPLI 100 M

Ersatzteile - Spare parts - Pièces de rechange - Reserveonderdelen - Parti di ricambio - Reservedele - Reservdelar  
 Varaosat - Części zamienne - Náhradní díly - Alkatrészek - Piese de schimb - Запасные части - 备件



①	Elast. Verbindung	Elastic connector	<b>JP43731</b>
②	Niveauerfassung	Level control	<b>JP50502</b>
③	Dichtung Niveauerfassung	Seal level control	<b>JP50479</b>
④	Steuerung	Control unit	
	BasicLogo AD 69MECR (08/2 ME)		<b>JP50496</b>
	BasicLogo AD 00R (08/2 M)		<b>JP50491</b>
	BasicLogo AD 46R (20/2 M)		<b>JP50493</b>
⑤	Rückschlagklappe	Check valve	<b>JP48139</b>
⑥	Klemmflansch	Clamping flange	<b>JP43708</b>
⑦	Steuerungsplatine	Control board	
	PCBA AD 69MECR (08/2 ME)		<b>JP50524</b>
	PCBA AD 00R (08/2 M)		<b>JP50497</b>
	PCBA AD 46R (20/2 M)		<b>JP50499</b>
	Kondensator S2 30uF/425V	Capacitor S2 30uF/425V	<b>JP50520</b>
	Kondensator S2 20uF/450V	Capacitor S2 20uF/450V	<b>JP50521</b>
	Widerstand 47K 3W (70 °C)	Resistor 47K 3W (70 °C)	<b>JP50522</b>
	Zeitrelais Ansprechverzög.1W	Time Relay ON-delay 1CO	<b>JP50523</b>
	Hilfssch.Baustein 11 DIL EM	Auxiliary switch 11 DIL EM	<b>JP47679</b>
⑧	Pumpe	Pump	
	08/2 ME		<b>JP46821</b>
	08/2 M		<b>JP46822</b>
	20/2 M		<b>JP46824</b>
⑨	Pumpenlüftung	Pump ventilation	<b>JP43732</b>
⑩	Wartungsdeckel	Service lid	<b>JP42798</b>
⑪	Überschiebmuffe	Collar	<b>JP47287</b>
⑫	Rundschnur	Round cord	<b>JP47968</b>
⑬	Steckdichtung	Plug in seal	<b>JP45099</b>
⑭	Behälter	Tank	<b>JP46820</b>
⑮	Auftriebssicherung	Anti floating	<b>JP43733</b>

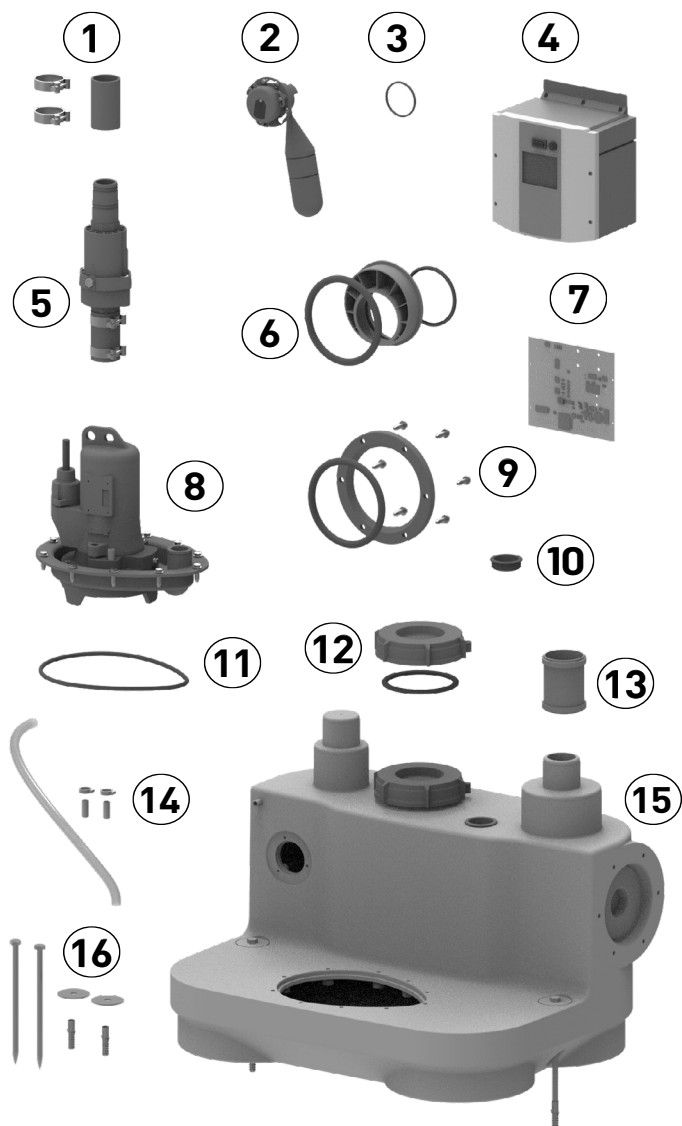

①	Elast. Verbindung	Elastic connector	<b>JP43735</b>
②	Niveauerfassung	Level control	<b>JP50467</b>
③	Dichtung Niveauerfassung	Seal level control	<b>JP50479</b>
④	Steuerung	Control unit	
	BasicLogo AD 610MECR (08/2 ME)		<b>JP50496</b>
	BasicLogo AD 00R (08/2 M)		<b>JP50491</b>
	BasicLogo AD 46R (20/2 M)		<b>JP50493</b>
⑤	Rückschlagklappe	Check valve	<b>JP48138</b>
⑥	Reduzierstück DN 150/DN 100	Reducer DN 150/DN 100	<b>JP48871</b>
⑦	Steuerungsplatine	Control board	
	PCBA AD 69MECR (08/2 ME)		<b>JP50524</b>
	PCBA AD 00R (08/2 M)		<b>JP50497</b>
	PCBA AD 46R (20/2 M)		<b>JP50499</b>
	Kondensator S2 30uF/425V	Capacitor S2 30uF/425V	<b>JP50520</b>
	Kondensator S2 20uF/450V	Capacitor S2 20uF/450V	<b>JP50521</b>
	Widerstand 47K 3W(70 °C)	Resistor 47K 3W(70 °C)	<b>JP50522</b>
	Zeitrelais Ansprechverzög.1W	Time Relay ON-delay 1CO	<b>JP50523</b>
	Hilfssch.Baustein 11 DIL EM	Auxiliary switch 11 DIL EM	<b>JP47679</b>
⑧	Pumpe	Pump	
	08/2 ME		<b>JP46833</b>
	08/2 M		<b>JP46834</b>
	20/2 M		<b>JP46835</b>
⑨	Klemmflansch	Clamping flange	<b>JP43713</b>
⑩	Steckdichtung D50xD59	Plug-in connection D50xD59	<b>JP45099</b>
⑪	Rundschnur	Round cord	<b>JP47967</b>
⑫	Wartungsdeckel	Service lid	<b>JP42798</b>
⑬	Überschiebmuffe	Collar	<b>JP47287</b>
⑭	Pumpenlüftung	Pump ventilation	<b>JP43732</b>
⑮	Behälter	Tank	<b>JP46832</b>
⑯	Auftriebssicherung	Anti floating	<b>JP43709</b>



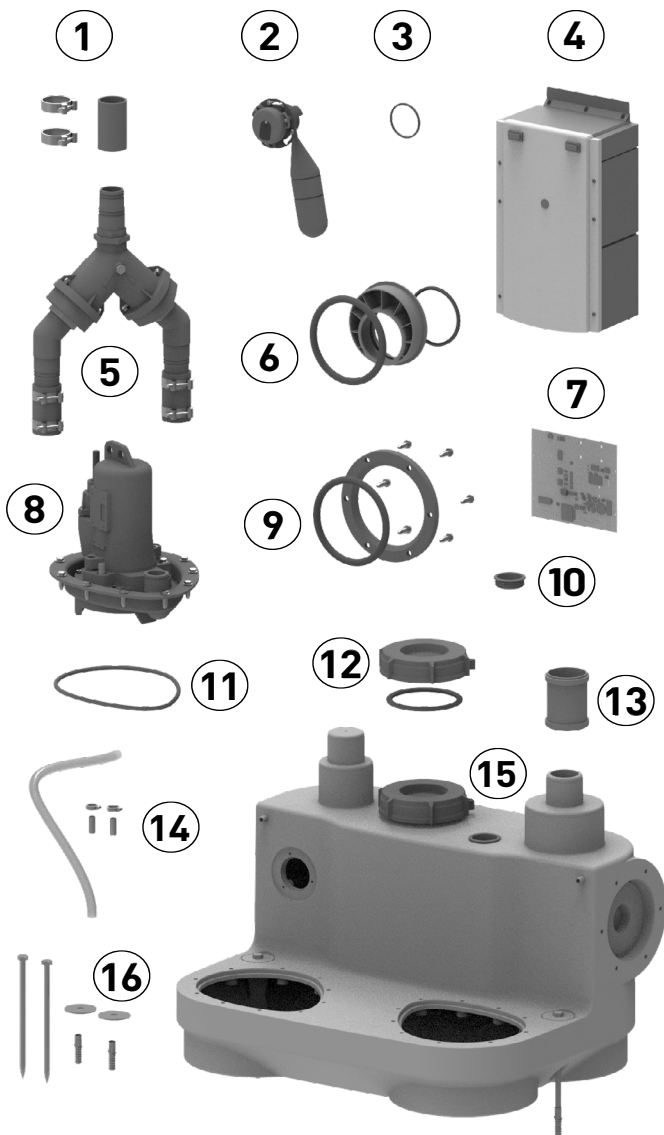

①	Elast. Verbindung	Elastic connector	<b>JP43735</b>
②	Niveaufassung	Level control	<b>JP50467</b>
③	Dichtung Niveaufassung	Seal level control	<b>JP50479</b>
④	Steuerung	Control unit	
	BasicLogo BD 610MECR (08/2 ME)		<b>JP50508</b>
	BasicLogo BD 25R (08/2 M)		<b>JP50505</b>
	BasicLogo BD 46R (20/2 M)		<b>JP50506</b>
⑤	Rückschlagklappe	Check valve	<b>JP46837</b>
⑥	Reduzierstück DN 150/DN 100	Reducer DN 150/DN 100	<b>JP48871</b>
⑦	Steuerungsplatine BD	Control board BD	<b>JP47304</b>
	Kondensator S2 30uF/425V	Capacitor S2 30uF/425V	<b>JP50520</b>
	Kondensator S2 20uF/450V	Capacitor S2 20uF/450V	<b>JP50521</b>
	Widerstand 47K 3W (70 °C)	Resistor 47K 3W (70 °C)	<b>JP50522</b>
	Zeitrelais A nsprechverzög.1W	Time Relay ON-delay 1C0	<b>JP50523</b>
	Hilfssch.Baustein 11 DIL EM	Auxiliary switch 11 DIL EM	<b>JP47679</b>
	Leistungsschutz 230V DIL EM-10 4 KW	Contactur 230V DIL EM 10 4 KW	<b>JP47671</b>
⑧	Pumpe	Pump	
	08/2 ME		<b>JP46833</b>
	08/2 M		<b>JP46834</b>
	20/2 M		<b>JP46835</b>
⑨	Klemmflansch	Clamping flange	<b>JP43713</b>
⑩	Steckdichtung D50xD59	Plug-in connection D50xD59	<b>JP45099</b>
⑪	Rundschnur	Round cord	<b>JP47967</b>
⑫	Wartungsdeckel	Service lid	<b>JP42798</b>
⑬	Überschiebmuffe	Collar	<b>JP47287</b>
⑭	Pumpenlüftung	Pump ventilation	<b>JP43732</b>
⑮	Behälter	Tank	<b>JP46836</b>
⑯	Auftriebssicherung	Anti floating	<b>JP43709</b>

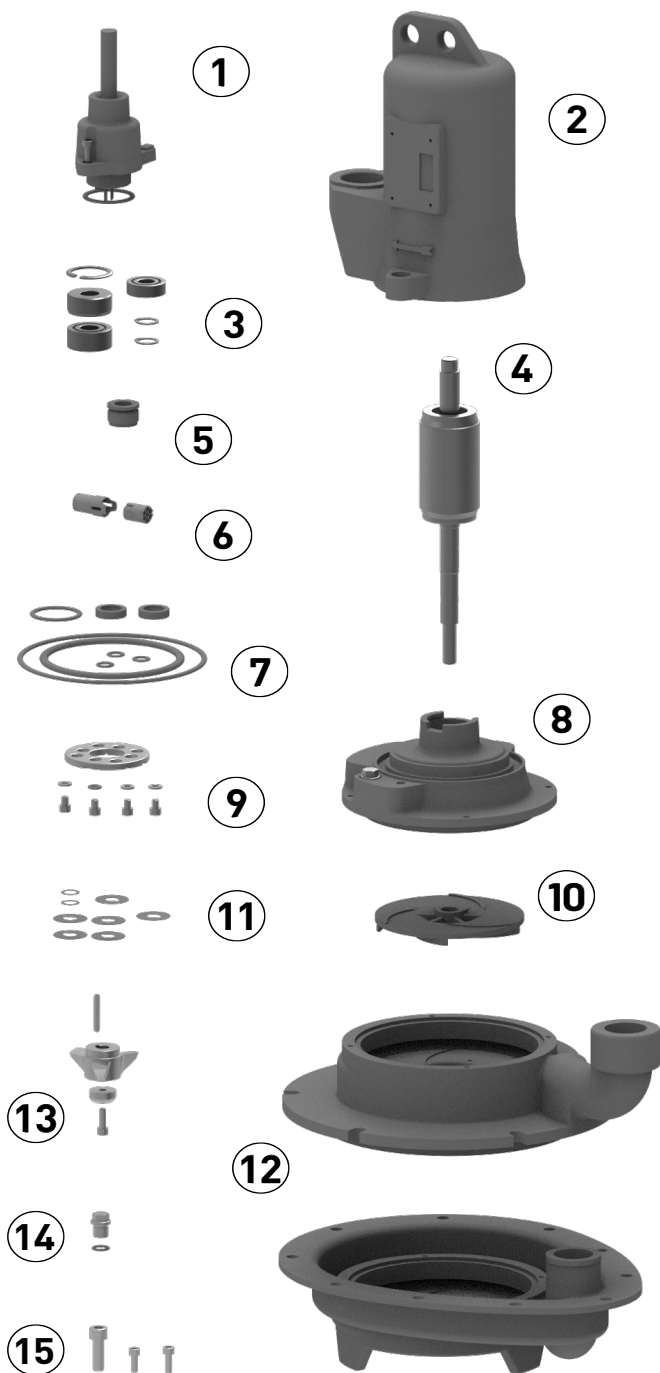

①	Leitung	Cable	<b>JP43717</b>
②	Stator + Gehäuse	Stator + Housing	
	08/2 ME		<b>JP43736</b>
	08/2 M		<b>JP43737</b>
	20/2 M		<b>JP43738</b>
③	Lagersatz	Bearing set	<b>JP45585</b>
④	Rotorwelle	Rotor shaft	
	08/2 ME		<b>JP47391</b>
	08/2 M		<b>JP46561</b>
	20/2 M		<b>JP46562</b>
⑤	Gleitringdichtung	Mechanical seal	<b>JP46043</b>
⑥	Coni Stecker	Coni plug	<b>JP46572</b>
⑦	Dichtungssatz	Seal set	<b>JP45628</b>
⑧	Lagerkammer	Bearing housing	<b>JP43739</b>
⑨	Schneidplatte	Cutter plate	<b>JP45470</b>
⑩	LaufRad	Impeller	
	08/2 M		<b>JP45467</b>
	20/2 M		<b>JP45468</b>
⑪	Pass-Scheiben	Shim rings	<b>JP46559</b>
⑫	Pumpengehäuse	Pump casing	
	100		<b>JP47309</b>
	500, 1000		<b>JP47390</b>
⑬	Schneidrotor	Cutter	<b>JP45472</b>
⑭	Ölschraube	Oil screw	<b>JP46046</b>
⑮	Schraubensatz	Screw set	<b>JP46563</b>



**PUMP TECHNICAL  
SERVICES LIMITED**



**THE SUBMERSIBLE PUMP SPECIALISTS**

✉ [service@pts-jung.co.uk](mailto:service@pts-jung.co.uk)

✉ [sales@pts-jung.co.uk](mailto:sales@pts-jung.co.uk)

Pump House  
Unit 12  
Bilton Road Industrial Estate  
Erith, Kent, DA8 2AN

☎ 01322 357 080

🌐 [pts-jung.co.uk](http://pts-jung.co.uk)