



**PUMP TECHNICAL
SERVICES LIMITED**



THE SUBMERSIBLE PUMP SPECIALISTS

MANUFACTURING | SALES | PROJECT DESIGN | INSTALLATION | MAINTENANCE AND REPAIRS

COMPLI

1010/4 BWE HL

1010/4 BW HL

1015/4 BW HL

1025/4 BW HL

1025/2 BW HL

1035/2 BW HL

1210/4 BW HL

1215/4 BW HL

1225/4 BW HL

1225/2 BW HL

1235/2 BW HL

EN Instruction Manual

 service@pts-jung.co.uk

 sales@pts-jung.co.uk

Pump House
Unit 12
Bilton Road Industrial Estate
Erith, Kent, DA8 2AN

 01322 357 080

 pts-jung.co.uk

You have purchased a product made by Pentair Jung Pumpen and with it, therefore, also excellent quality and service. Secure this service by carrying out the installation works in accordance with the instructions, so that our product can perform its task to your complete satisfaction. Please remember that damage caused by incorrect installation or handling will adversely affect the guarantee. Therefore please adhere to the instructions in this manual!

This appliance can be used by children aged 8 years or over and by persons with limited physical, sensory or intellectual capabilities, or with limited experience and knowledge, provided that they are supervised or have been instructed in the safe use of the appliance and are aware of the dangers involved. Children must not be allowed to play with the appliance. Cleaning and user maintenance must not be carried out by children unless they are supervised.

If this unit is equipped with a mains connection line without a plug or other means of disconnection from the mains, a complete disconnecting device must be installed on site in the fixed electrical installation in accordance with the installation regulations. A main switch of overvoltage category III can be installed as a complete disconnecting device. If the mains connection cable of this unit is damaged, it must be replaced by the manufacturer or its customer service or a similarly qualified person in order to avoid hazards.

Damage prevention in case of failure

Like any other electrical device, this product may fail due to a lack of mains voltage or a technical defect.

If damage (including consequential damage) can occur as a result of product failure, the following precautions can be taken at your discretion:

- Installation of a water level dependent (under circumstances, mains-independent) alarm system, so that the alarm can be heard before damage occurs.
- Inspection of the collecting tank/chamber for tightness up to the top edge before – or at the latest, during – installation or operation of the product.
- Installation of backflow protection for drainage units that can be damaged by wastewater leakage upon product failure.
- Installation of a further product that can compensate in case of failure of the other product (e.g. duplex unit).
- Installation of an emergency power generator.

As these precautions serve to prevent or minimise consequential damage upon product failure, they are to be strictly observed as the manufacturer's guideline – in line with the standard DIN EN specifications as state of the art – when using the product (Higher Regional Court Frankfurt/Main, Ref.: 2 U 205/11, 06/15/2012).

SAFETY INSTRUCTIONS

This instruction manual contains essential information that must be observed during installation, operation and servicing. It is therefore important that the installer and the responsible technician/operator read this instruction manual before the equipment is installed and put into operation. The manual must always be available at the location where the pump or the plant is installed.

Failure to observe the safety instructions can lead to the loss of all indemnity.

In this instruction manual, safety information is distinctly labelled with particular symbols. Disregarding this information can be dangerous.



General danger to people



Warning of electrical voltage

NOTICE! Danger to equipment and operation

Qualification and training of personnel

All personnel involved with the operation, servicing, inspection and installation of the equipment must be suitably qualified for this work and must have studied the instruction manual in depth to ensure that they are sufficiently conversant with its contents. The supervision, competence and areas of responsibility of the personnel must be precisely regulated by the operator. If the personnel do not have the necessary skills, they must be instructed and trained accordingly.

Safety-conscious working

The safety instructions in this instruction manual, the existing national regulations regarding accident prevention, and any internal working, operating and safety regulations must be adhered to.

Safety instructions for the operator/user

All legal regulations, local directives and safety regulations must be adhered to.

The possibility of danger due to electrical energy must be prevented.

Leakages of dangerous (e.g. explosive, toxic, hot) substances must be discharged such that no danger to people or the environment occurs. Legal regulations must be observed.

Safety instructions for installation, inspection and maintenance works

As a basic principle, works may only be carried out to the equipment when it is shut down. Pumps or plant that convey harmful substances must be decontaminated.

All safety and protection components must be re-fitted and/or made operational immediately after the works have been completed. Their effectiveness must be checked before restarting, taking into account the current regulations and stipulations.

Unauthorised modifications, manufacture of spare parts

The equipment may only be modified or altered in agreement with the manufacturer. The use of original spare parts and accessories approved by the manufacturer is important for safety reasons. The use of other parts can result in liability for consequential damage being rescinded.

Unauthorised operating methods

The operational safety of the supplied equipment is only guaranteed if the equipment is used for its intended purpose. The limiting values given in the "Technical Data" section may not be exceeded under any circumstances.

Instructions regarding accident prevention

Before commencing servicing or maintenance works, cordon off the working area and check that the lifting gear is in perfect condition.

Never work alone. Always wear a hard hat, safety glasses and safety shoes and, if necessary, a suitable safety belt.

Before carrying out welding works or using electrical devices, check to ensure there is no danger of explosion.

People working in wastewater systems must be vaccinated against the pathogens that may be found there. For the sake of your health, be sure to pay meticulous attention to cleanliness wherever you are working.

Make sure that there are no toxic gases in the working area.

Observe the health and safety at work regulations and make sure that a first-aid kit is to hand.

In some cases, the pump and the pumping medium may be hot and could cause burns.

For installations in areas subject to explosion hazards, special regulations apply!

AREAS OF APPLICATION

The Compli sewage lifting stations are TÜV certified and are suitable for the disposal of wastewater from toilets and urinals, and domestic wastewater containing the usual impurities.

The units have a level controller that switches the pump on and off depending on the level of the water. An integrated alarm system beeps if there is a malfunction, even if this is only temporary.

If the pump overheats, the motor cuts out due to the winding thermostat. After the thermostat has switched off the system, pull out the mains plug before remedying the fault, since the device can switch itself on again automatically if the power is still connected. A direct malfunction message is not generated.

The tanks can withstand submersion to a depth of not more than 2 m of water and a submersion period of up to 7 days.

The control unit cannot withstand submersion, but is splash-proof in accordance with IP 44.

If installed in compliance with the regulations and used properly, then this control unit meets the protective requirements of the EMC Directive and is suitable for domestic use and connection to a power supply from the grid. When connected to an industrial mains within an industrial operation with power supply provided by a company-own high-voltage transformer, insufficient immunity to interference has to be expected.

When using the pumps, the relevant national laws, regulations and stipulations must be adhered to, for example:

- Sewage disposal units for building and ground drainage systems (e.g. EN 12050 and 12056 in Europe)
- Installation of low voltage systems (e.g. VDE 0100 in Germany)
- Safety and working materials (e.g., BetrSichV and BGR 500 in Germany)

- Safety in wastewater systems (e.g., GUV-V C5, GUV-R 104 and GUV-R 126 in Germany)
- Electrical systems and operating resources (e.g., GUV-V A3 in Germany)
- Explosion protection EN 60079-0, EN 60079-1, EN 60079-14, EN 60079-17 and EN 1127-1

Scope of supply

- Tank with pumps and clamp flange for inlet
- Reducer DN 150 / DN 100 for Compli 1000
- Slip-on socket pipe for ventilation pipe (Compli 1200 flexible connection with hose clamps)
- Connection flange for pressure pipe
- Flexible connection with hose clamps for the pressure pipe
- Plug-in seal(s) for the diaphragm hand pump or additional DN 50 inlet
- Fixing materials for tank
- Non-return valve for the pressure pipe
- Control

Mode of operation: intermittent operation S3; see "Technical Data"

INSTALLATION

The pump must be installed so that it is buoyancy-proof and free-standing. At least 60 cm free working space must be provided around and above the parts that require access for operation or maintenance.

Ventilation: The ventilation pipe must be vented above roof level.

Inlet: A wastewater sluice valve must be installed in the inlet at the front of the tank.

Pressure pipe: A further wastewater sluice valve must be installed behind the non-return valve in the pressure pipe. If the non-return valve is not included in the scope of delivery of the pumping unit, then an EN 12050 certified swing-type check valve must be fitted.

The pressure pipe must be laid in a loop above the local backup level.

A pump sump must be provided to facilitate the disposal of water from the pump installation area.

NOTICE! All bolts that are used for fixing individual components to the tank should be tightened with a torque of no more than 6 Nm.

Installing the tank

Close the sluice valve in the inlet (accessory) to prevent any leakage of water during the installation work.

Units must be slid onto the inlet pipe, together with the clamp flange, as far as possible and then aligned.

If a DN 150 side inlet is used, the inlet must first be opened at the marked position using a hole saw, Ø 152, and then deburred. The standard inlet must then be closed using a closure kit (accessory) and the switch-on level must be reset.

In the case of Compli 1000, the inlet can be reduced from DN 150 to DN 100 if the enclosed reducer is first of all fitted to the clamp flange.

Tighten the hexagon screws on the clamp flange.

Mark the positions of the holes for fixing the tank to the floor, then drill the holes.

Insert the wood screw, together with the washer and wall plug, into the drill hole in the tank and tighten it.

NOTICE! Ensure that the tank does not become deformed due to overtightening the screws, otherwise this could result in leakage.

The tanks for Compli 1200 units are additionally fixed with two brackets at the sides.

Installing the ventilation

Connect the ventilation pipe to the top right of the tank using the DN 70 slip-on socket pipe and vent it above roof level.

For Compli 1200, cut off the top right Ø 78 mm pipe connection at the marking and deburr it. After this, connect the ventilation pipe with the DN 70 flexible connector and vent it above roof level.

Installing the pressure pipe

Fit the following to the discharge flange:

1. Non-return valve
2. Stop valve (accessory)
3. Connection flange and
4. connect the pressure pipe with the flexible connector and loop it over the local backup level.

Additional connection, DN 50, vertical

This connection is used for emergency disposal.

Open the pipe connection at the marking using a hole saw, deburr the edges, and put the plug-in seal, 58/50, into place.

Mounting hand diaphragm pump (accessory)

Push the inlet pipe, with an external diameter of 50 mm, into the tank through the plug-in seal. The distance from the bottom of the tank must be at least 50 mm.

Fix the diaphragm hand pump to the wall in an easily accessible position. Connect it to the pushed-in pipe and then connect the pressure pipe to the diaphragm hand pump. Here, too, the pressure pipe must be looped over the local backup level.

Additional inlet, DN 50, horizontal

Not Compli 1200. Using a hole saw, open the additional inlet by cutting along the pre-cut groove. Deburr the edges.

Put the plug-in seal, 58/50, into place.

Push the inlet pipe, with an external diameter of 50 mm, into the tank through the plug-in seal.

Installing the control unit

NOTICE! Only qualified electricians may carry out electrical works to the pump or the controls.

NOTICE! Never put the mains plug or open cable end in water! If water gets into the plug, this can cause malfunctions and damage.

Only operate the control unit in dry rooms and keep the housing closed at all times. The control unit must be easily accessible to enable it to be checked at any time. High humidity and condensation can destroy the controls!

Alternating current (AC) units with plug

Only connect the pump to electrical sockets that have been installed properly in a dry room, in accordance with the regulations, and are fitted with at least a 16 A (delay) fuse and RCD-safety switches (30mA).

Three-phase current units with plug

For the electrical connection of the sewage disposal unit, a five pole CEE power socket is required. This must be located in a dry room (3/N/PE-230/400 V) and RCD-safety switches (30mA).

NOTICE! Only slow-blow fuses or automatic fuses with C characteristics are to be used as pre-fuses for the pump. See circuit diagram.

Installations with free cable end

If this unit is equipped with a mains connection line without a plug or other means of disconnection from the mains, a complete disconnecting device must be installed on site in the fixed electrical installation in accordance with the installation regulations. A main switch of overvoltage category III can be installed as a complete disconnecting device.

Installations without mains connection line with main switch

If this unit is equipped without a mains connection line, a complete disconnecting device must be installed on site in the fixed electrical installation in accordance with the installation regulations. A main switch of overvoltage category III can be installed as a complete disconnecting device. The mains connection line is connected directly to the main switch.

NOTICE! Only slow-blow fuses or automatic fuses with C characteristics are to be used as pre-fuses for the pump.

See circuit diagram.

Switching levels

The switch-on and switch-off points are set ex works for the standard inlet height of the respective system. In exceptional cases, however, they can be changed under the menu item "Level control".

Alarm relays

As alarm outputs, a potential-loaded alarm relay (protected by internal control fuse F2) and a potential-free changeover contact are available.

External 230V~ flashing light or warning light (accessory)

Non-isolated alarm relay (230 V AC, fused with 2A slow-blow), terminals N/X2 (NO contact) or N/X3 (NC contact). The relay makes contact if there is a fault (operating current principle).

If a warning light (with bulb) is shown in the system menu, set the parameter "flashing alarm?" to "yes."

If a flashing light (with discharge bulb) is shown in the system menu, set the parameter "flashing alarm?" to "no."

Connecting a remote fault reporting system

- Potential-free centralised alarm relay
The changeover contact (40-41-42) can be loaded with max. 5A/250V AC. The relay drops out with error and power failure (quiescent current principle).
- Potential-free high water relay
The changeover contact (50-51-52) can be loaded with max. 5A/250V AC. The relay makes contact if there is a fault (operating current principle).

Rechargeable battery for power failure indicator

The control unit can optionally be fitted with a 9V NiMh rechargeable battery. The "BRX" jumper must be set if the buzzer is to sound.

CAUTION!

Use only the manufacturer's 9V NiMh rechargeable batteries! There is a risk of explosion if dry-cell batteries or lithium batteries are used!

NOTE! Check the function of the rechargeable battery at regular intervals! The service life is about 5-10 years. Note the insertion date on the battery, and after five years the battery should be replaced as a precautionary measure.

Test run and functional check

1. Open the maintenance cover of the tank.
2. Connect the unit to the power supply.
3. Open the shut-off valves in the inlet and the pressure pipe.
4. Fill the tank up to the switch-on level.
5. The pump will now switch on and empty the tank. Observe the pumping process through the maintenance opening.
6. Lift the float of the level controller slowly by hand until it is above the switch-on point and hold it there until the alarm is triggered.
7. Then close the maintenance opening with the cover and seal.
8. Check to ensure that the tank, fittings and pipes are watertight, by carrying out several switching runs.

OPERATION

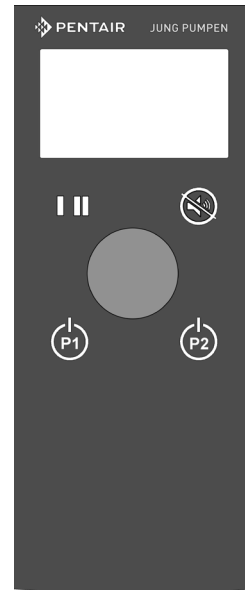

Display

LED pump 1 and pump 2
Acknowledgement button
and menu exit

OK Rotary knob
Select = turn,
Acknowledge = press

Manual-0-automatic
Pump 1 and pump 2

The control unit has a graphic LCD display. The data is evaluated and updated at short intervals, which can sometimes look like flickering. The backlighting is activated for a limited time by pressing a button. The contrast can be changed in the system settings menu item.

It is operated with a rotary knob and three membrane keys: an acknowledgement button and manual-0-automatic buttons for the pump(s).

The two LEDs show the operating status of the pumps:

- Continuous green light = Operational
- Green flashing - Pump in operation
- Continuous red light = Fault
- Red flashing - Fault, pump in operation
- Orange = Maintenance due

Operating modes

In addition to the automatic operating mode described above, each pump can also be switched on and off manually using the operating button.

The operating status of the control unit is shown in the display; the existing operating mode is highlighted as a negative image.

MANUAL/ON

The pump continues to run in manual mode until a different operating mode is selected.

OFF

The pump is switched off and remains off until a different operating mode is selected. It will remain off even if a high-water situation occurs.

AUTO

The pumps are switched on and off by the control unit depending on the water level. However, if there is dry-running protection, this will take priority over the automatic switching.

NOTE! If the control unit is password-protected, the password must first be entered under "Settings" to change the operating mode.

! WARNING!

For repair and maintenance work on pumps or control units, do not use the "Off" function, but always de-energize the system by unscrewing the back-up fuses or via a main switch and secure against being switched on again!

NOTICE! If unusually large quantities of wastewater flow into the unit (e.g. when a pool is drained), partially close the shut-off valve at the inlet until the unit can operate normally again, switching on and off, (S3 Intermittent duty, not pumping continuously, since this could overheat the pump motor).

Inspection

To maintain operational reliability, carry out a visual inspection of the unit, including the pipe connections, once a month.

Faults / alarm

Faults are signalled via the red LED, a built-in buzzer, a non-isolated relay "Alarm", a potential-free relay "Centralised alarm" and a potential-free relay "High water".

The relay "Centralised alarm signal" can be delayed up to 60 minutes in order not to trigger an alarm if there is a short-term high water level. The deployment of a service technician would be unnecessary in this case.

The fault text is shown in the display and alternates with the standard display text. If more than one fault has occurred, the relevant messages will be shown consecutively in the display. In addition, the high water alarm is reported to a separate potential-free relay.

OPERATION

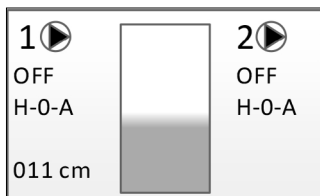

The standard display shows the operating mode of the control unit, the switching status, the motor current and the level.

To enter the menu, turn the rotary knob to the right.

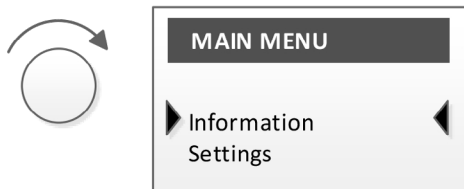

INFORMATION

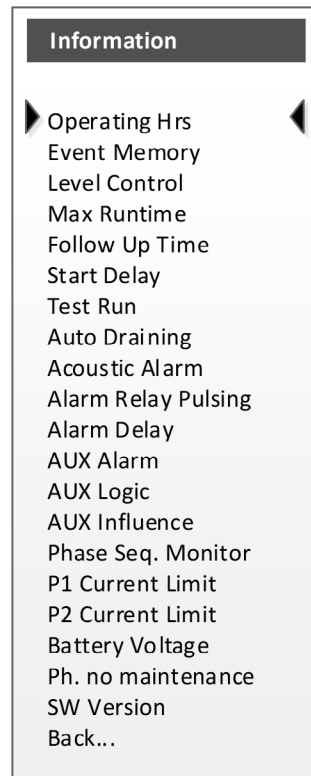

- Operating hours
Displays the operating hours per pump and the pump switching cycles
- Event memory
Shows the error messages of the system. The newest message is at the top, older ones below. After 70 messages, the oldest message is deleted from the memory.
- Level control
Displays the level control system that is set
- Max. runtime
Displays the running time limit that has been set for the pumps (S2/S3 time)
- Follow-up Time
Displays the follow-up time that has been set for static pressure systems
- Start delay
Display the period of time that has been set between supplying power supply and being operational
- Test run
Displays whether the test run is activated
- Auto draining
Displays the interval that has been set for the automatic pumping procedure in analogue systems, to prevent long stationary periods
- Acoustic alarm
Displays whether the buzzer is activated
- Alarm relay pulsing
Shows whether the relay works in cycles in the event of an alarm or whether it is continuously energised
- Alarm delay
Shows currently set delay for alarm relay
- AUX alarm
Shows whether the signalling is switched on or off

- AUX logic
Shows whether the auxiliary input works as an NC contact or an NO contact
- AUX influence
Shows, what influence the auxiliary input as on the pumps
- Phase seq. monitor
Shows whether the check on the direction of rotation is activated
- P1 current limit
Shows the current limitation that has been set for pump 1
- P2 current limit
Shows the current limitation that has been set for pump 2
- Battery voltage
Displays the voltage of the 12 V battery (only with accessory RTC module)
- Maintenance service
Call number of the responsible customer service
- SW Version
Shows the current software version

SETTINGS

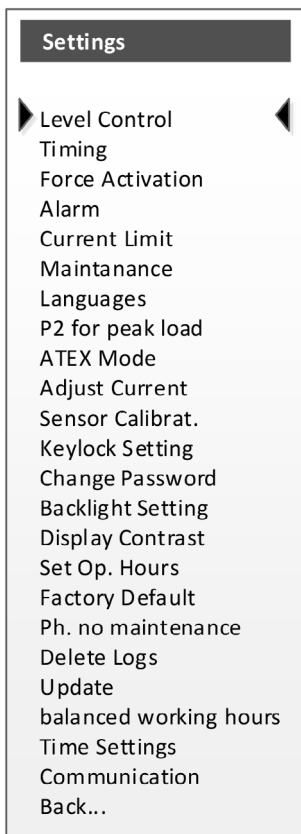

If you wish to change a parameter in this system menu, you will be asked to enter a password (4-digit number).

NOTE! The password is set to "3197" in the factory. If the password is changed and then forgotten, the device must be re-activated by the manufacturer's customer service department. It is not possible for the user to reset the system!

If more than about one minute passes in the system menu without any entry being made, the control unit automatically switches back to the standard display.

NOTE! Only the menu items relevant to Compli lifting systems are described.

Level Control

The different types can be selected here. The switching levels for the various lifting stations are already pre-set. In exceptional cases, however, they can be changed under this menu item.

Timing

Max running time

The running time of the pump can be restricted to a maximum duration. This function is necessary for short duration operation or intermittent duty operation (S2 and S3 operation) of the pump.

The times are dependent on the type of pump and can be found in the technical data provided with the pump. If the pump runs continuously for longer than the time specified here, an alarm will be triggered.

The maximum runtime monitoring is only active in ATEX mode and can be reset after it has been triggered by the acknowledgement button. If the acknowledgement button is not pressed, an automatic reset occurs at the S2 time after 7 times the triggering time and at the S3 time triggering after the S3 pause time.

- S2 time [Short-time operation]

When the pump is not submerged, it operates only for a pre-set period (maximum running time 1 to 120 minutes). This is to prevent the temperature of the motor from rising above its maximal permissible operating temperature. The value for the maximum permissible running time can be found in the technical data provided with the pump. The subsequent pause time (restart lock-out), during which the pump remains switched off, must be long enough to allow the motor to cool down to the ambient temperature. This is generally equal to the operating time multiplied by a factor of seven.

- S3 time (intermittent duty)

The pump operates only for a short period before being switched off again if it is not submerged. The switch-on and switch-off times are expressed as percentages of 10 minutes, e.g. for an S3 time of 30%, the pump is switched on for not longer than 3 minutes and then switched off for 7 minutes. This operating mode ensures that the pump does not overheat.

- Deactivated

The S2/S3 time monitoring can be deactivated here

Start-up delay

In order to avoid mains disturbances in areas with many pumping stations, the control unit is equipped with a variable start-up delay. The delay time can be set from 0 to 300 seconds.

Force activation

Alarm

In this menu all settings for the buzzer and the alarm relays are made.

Acoustic alarm

If this function is deactivated, only the integrated alarm buzzer is switched off.

Options: Off/on.

If a fault is acknowledged, the buzzer stops and the non-isolated relay drops out. However, the potential-free relay contacts remain active. If the Acknowledge button is then pressed again and the fault is no longer present, these relays are also reset to their original position.

An external alarm acknowledgement is possible via terminals 14/15.

Alarm relay flashes

You are able to select here whether the non-isolated alarm relay switches at one-second intervals when a fault occurs or whether it remains on all the time: On = switches on every second, Off = permanently on.

An alarm delay also affects this relay.

Delay alarm

NOTE! No alarm delay is available in 9V battery operation.

In order not to trigger an alarm immediately with short-term events, a delay can be set for the switching of the alarm contacts.

Setting range from 1 to 3600 seconds. A value of 0 deactivates this function!

- Centralised alarmtime-delayed acoustic alarm and the relay drops out with a time delay.
- High water alarm
 - Analogue level detection: the relay makes contact with a delay

AUX Alarm

The AUX alarm can be switched on and off here.

AUX logic

NOTE! Non-isolated contacts can cause damage to the control unit.

Only potential-free digital contacts such as rain sensors, external interlocks with other pumping stations or RCD switch auxiliary contacts may be connected to the Aux input.

The switching logic can be selected as NC contact or NO contact.

NOTE! Locked pumps also start with a high water alarm.

AUX influence

"Aux influence" can be used to select whether an alarm switches off one or both pumps ("P1 OFF", "P2 OFF" or "Both OFF") or does not have any effect ("None"). In either case, the triggered alarm appears in the display and activates the potential-free and non-isolated alarm relays as soon as the pre-set alarm delay time has expired.

Direction of rotation check

Monitoring of the rotational direction can be activated in this menu. An alarm is triggered if a phase failure or if an anticlockwise rotating field is detected.

Options "On" and "Off".

This function is activated as standard and does not need to be

deactivated when supplied with AC power.

Buzzer reactivation

After a buzzer acknowledgement, the alarm is automatically reactivated if the fault persists for another 4 / 8 / 12 hours. Factory default setting: 4 hours.

External relay

This menu item is enabled when the optional module for individual fault messages D02 or D06 is connected.

For each relay it is selected whether operating current or quiescent current principle and which faults trigger the relay.

Current limit

In this menu, the maximum motor current can be entered. This value will be compared with the measured motor current. If the measured motor current is higher than the entered maximum motor current, the motor is switched off depending on a simulated time-current characteristic of the motor protection relay.

Maintenance

Setting the next maintenance reminder after 90/180/365 days or OFF.

Additional input possibility of the last maintenance, format DD.MM.YYYY. The input is only an information text and has no influence on switching functions.

Languages

Setting the menu language German, English, Finnish, French, Dutch, Italian, Polish or Swedish.

P2 for peak load

Setting option On / Off

When "ON", the pump at rest is switched on when the peak load level is reached.

When "OFF", the pump switches once to the idle pump when the peak load level is reached.

ATEX mode

Adjust current

Only for the manufacturer's Customer Service.

Sensor calibration

For readjustment, fill the container (fill level of the respective type see appendix) and then select this menu item "Sensor calibration".

Calibration is performed automatically when 20s have elapsed or the OK button is pressed. The calibration can be aborted by pressing the acknowledge button prematurely.

Keylock setting

All settings and the operating mode selection Manual-0-Auto-automatic can be locked. The lock is automatically activated after one minute.

- Key lock off (remove all locks)
- Unlock key: to unlock, press the acknowledgement button for at least 3 seconds
- Unlock password: enter password to unlock

Change password

The password for the setting menu can be changed here; the factory setting is 3197.

Backlight setting

Auto OFF- Backlighting is switched off after 1 minute
Always ON - Backlighting is always ON.

Display contrast

The contrast can be changed using the bar display.

Set operating hours

P1 Op. hrs P1 Cycles

P2 Op. hrs P2 Cycles

Here the operating hours (Op. hrs) or the switching cycles can be adjusted. (when replacing the control unit or installing a used pump.)

Factory default

Resets the control unit to the factory settings. The existing configuration, all event messages and operating data will be overwritten. At the next start-up, the initial commissioning menu will be displayed.

Maintenance service

The phone number for the appropriate Customer Service can be deposited here.

Update

Only for calling the manufacturer's Customer Service.

Balanced working hours

If this menu item is active, the pump with the lowest operating hours is always selected.

Time settings

Only for RTC module accessories: Time and date can be set.

Communication

Only with accessory "GSM module": Communication settings can be made.

ERROR MESSAGES

Rotational field error. There is no clockwise rotating field, one phase is missing or the neutral conductor is not connected.

High water alarm. This error message is shown if the level of water measured lies above the pre-set alarm level or if the high-water float switch is triggered. The pump is then switched on, provided that there is no fault of the pump.

Error Aux. The auxiliary input has been activated. The consequences for the pump control unit depends on the configuration.

Motor protection. The motor protection switch or the motor protection relay of the pump has triggered. The pump is then switched off. If the error condition no longer exists, the control unit starts up again. This error condition will also be saved in the event of a power failure. The message is saved in the EEPROM of the processor, which is zero voltage safe.

Overcurrent. If the measured motor current (current transformer measurement on the board) is above the entered maximum motor current, the pump is switched off depending on a simulated time-current characteristic of the motor protection relay. After 30 seconds an automatic reset is performed.

NOTE! This function does not replace the mechanical motor protection switch or the overcurrent relay!

Thermostat. The pump's thermal contact has been triggered. The pump is then switched off.

The pump starts automatically once the thermostat has cooled down.

Running time. The maximum running time of the pump has been exceeded.

MAINTENANCE

Maintenance and inspection of this product must be carried out in accordance with EN 12056-4. To ensure continued reliability of service, we recommend that you take out a service contract.

NOTICE! The maintenance of the sewage lifting station and maintenance measures are carried out by specialists at intervals of 3 months in commercial premises, multi-family homes in 6 months or 12 months in family homes.



WARNING!

Before carrying out any works: disconnect the pump and the controls from the mains and take steps to ensure that they cannot be energized again.



WARNING!

Check the cable for mechanical or chemical damage. Damaged or kinked cables must be replaced by the manufacturer.

We recommend that the following works be included in the service:

1. Check the connection points for watertightness and inspect the areas surrounding the unit and the fittings.
2. Operate the shut-off valves and check that they move easily. Adjust and grease them if necessary.
3. Open and clean the swing-type check valve; check the seat and valve (ball)
4. Clean the pump and the pipes where they connect to the unit; check the impeller and the bearings.



CAUTION!

Worn impellers can have sharp edges.

5. Oil check. If necessary top up or change oil (if oil chamber available).
6. Clean the inside of the tank (as necessary, or if especially required); remove any grease, for example.
7. Check the condition of the collecting tank.
8. Flush the system through with water once every 2 years.
9. Inspect the electrical section of the unit. The control unit itself is maintenance-free, but if a rechargeable battery is fitted, then it should be checked regularly to ensure that it is in good working order. To do so, unplug the unit from the mains and lift the float of the level controller slowly by hand and hold it there until the alarm is triggered.

10. In addition, clean the float if necessary.

When all the servicing tasks have been performed, carry out a test run and then put the unit back into operation. The service must be documented, giving details of the important data and of all the tasks carried out.

Oil check

(Only applies for units 25/2 and 35/2). First of all, unscrew the hexagon screws or Allen screws around the pump and lift the pump and impeller off the tank. The drain plug is labelled "Ö!". In order to check the mechanical seal, the oil, including any residue, must be drained from the oil reservoir and collected in a clean measuring container.

- If the oil is contaminated with water (milky), an oil change must be carried out. Check again after a further 300 operating hours, but at the very latest after 6 months!

- However, if the oil is contaminated with both water and pollutants, then not only the oil must be replaced, but the mechanical seal as well.

For monitoring the oil reservoir, it is also possible to retrofit the electrode of our "DKG" seal leak detector in place of the "DKG" sealing screw.

Changing the oil

(Only applies for units 25/2 and 35/2). To ensure operational liability, the first oil change should be carried out after 300 operating hours, with further oil changes carried out after every 1000 operating hours.

If the number of operating hours is very low, an oil change should still be carried out at least once a year.

If wastewater with strongly abrasive constituents is being pumped, the oil changes should be carried out at correspondingly shorter intervals.

Use HLP hydraulic mineral oil, viscosity class 22 to 46, e.g. Mobil DTE 22, DTE 24, DTE 25, to replace the oil in the oil reservoir.

The quantity of oil required is 700 ml for the MultiFree pumps 25/2 BW and 35/2 BW.

NOTICE! The oil reservoir may only be filled with the specified quantity of oil. Overfilling will result in the pump being rendered inoperable.

QUICK TIPS FOR REMEDYING FAULTS

WARNING!

Before carrying out any work: Disconnect the pump(s) and the control unit from the mains by unscrewing and taking out the pre-fuses, and take action to ensure that no one else can re-connect them to the power supply.

NOTE! Work on the control unit must be carried out by qualified electricians only!

- System does not work either in automatic or manual mode.
No mains power; check fuses and RCD switch, the operating mode for the pump should not be set to "0".
- System does not work, "Pump motor protection" is displayed
The motor protection relay or the motor protection switch has switched off. Check motor protection settings and set the rated power for the pump. Acknowledge with the acknowledge button and reset the motor protection switch by hand.
- Motor protection shuts off after only a short time
Pump impeller blocked -> Clean (refer to pump manual)
Motor contactor does not switch through all phases-> Replace
Motor fault -> Call customer service personnel
- Backpressure, water rising slowly
Intake line blocked -> Clean and unblock.
- Pump delivers too little, high water alarm
Check gate valve in pressure pipe and open completely, clean non-return valve and flush out pressure line.
- Pump thermostat
Let the pump cool down, and acknowledge with the OK button.
- Display does not show any readings
No mains power; check fuses and RCD switch, switch on the main switch if necessary.
- Green LED does not light up
No mains power, check fuses and RCD switch, switch on main switch if necessary, operating mode of the pump must not be set to "0".
- Red LED lights up
The fault is shown in the display; then confirm with the acknowledge button.
- No access to the menu
Password incorrect.

TECHNICAL DATA

Weight	depending on type 4-6 kg
Protection category	IP 44
Operating voltage	1/N/PE x 230 V, 50 Hz 3/N/PE x 400 V, 50 Hz
Power consumption of control unit	approx. 8 W
Control fuse	F1 fine-wire fuse 5x20 mm, 6.3 A T/MT; EN 60127-2-5, DIN 41571-2
Fuse alternating current output	F2 fine-wire fuse 5x20 mm, 2.0 A T/MT; EN 60127-2-5, DIN 41571-2
High water alarm emergency supply (optional)	9 V NiMH rechargeable batteries
Terminals	2.5 mm ² push-in terminals on the PCB 4 mm ² push-in terminals on top hat rail Screw terminals 4 mm ² at the motor protection relay/motor contactor Screw terminal 6/10 mm ² for potential equalisation
Motor protection	Motor protection switch on top hat rail / motor protection relay on contactor
Monitoring of rotational field / phase failure	Error message given for anti-clockwise rotating field and if there is a power phase failure
Temperature range in operation	-20 ... 50°C
Temperature range in storage	-20 ... 70°C
Air humidity	0 to 90% RH, with no condensation
Compli potentiometer	5 kOhm
Level switch, input	24 V, 4 mA
High water alarm, input	12 V, 7 mA
Powered alarm relay	230 V AC, max 2 A (AC1)
Potential-free alarm relay	5A, 250 V AC
Method used for measuring current	via current transformer and A/D converter
Current transformer	0 - 20 A, ± 10%

Parameter Factory default setting Client setting

Level detection

Level detection	Compli	
base load ON	depending on analogue level detection	
Base load OFF	depending on analogue level detection	
peak load ON	depending on analogue level detection	
Peak load OFF	depending on analogue level detection	
High water	depending on analogue level detection	
Upper edge of pump	depending on analogue level detection	

Time control

Max. running time	Deactivated	
S2 Short-time operation	10 Min	
S3 Intermittent duty	10%	
Follow-up time	Standard / 6 s	
Start-up delay	0 s	

Forced switching on

Test run	OFF	
Auto. Pumping out	000 h	

Alarm

Acoustic alarm	ON	
Alarm relay flashes	OFF	
Delay alarm	0 s	
AUX logic	NO contact	
AUX influence	None	
Direction of rotation check	Activated	
Buzzer reactivation	4 hours	
Overcurrent limit		
P1 Current limit	0 = deactivated	
P2 Current limit	0 = deactivated	
Maintenance		
Days	365 days	
Last maintenance	01/01/2016	

Further settings

P2 Peak load	ON	
ATEX mode	OFF	
Compensate for operating hours	NO	
Lock setting	Key lock OFF	
Change the password	3197 <User must first confirm old password>	
Light settings	Auto OFF	
Maintenance service	01805 188881	

Communication

SIM card PIN no.		
Cell phone provider		
APN	APN.com	
Authentication		
User name		
Password		
Receiver SMS1		
Receiver SMS2		
Receiver SMS3		
SMS acknowledgement	OFF	
SMS response time	5 minutes	
Routine messages	10 days at 8:00	
Additional call for SMS	OFF	
Station ID	SGJU4	
Station name	PENTAIR-HighLogo	

Error transmission

△ Start error		
▽ Error end		
E-mail address 1		
E-mail address 2		
E-mail address 3		







E-mail settings

SMTP server	smtp.gmail.com	
Port	465	
Encryption	Yes	
User ID		
Password		

 0197	JUNG PUMPEN GmbH - Industriestr. 4-6 33803 Steinhagen, Germany 20 466.12.2022.10	EN 12050-1:2001; 2015 Station de relevage pour effluents contenant des matières fécales Complii 1010/4 BWE HL (JP50105) Complii 1010/4 BW HL (JP50106) Complii 1015/4 BW HL (JP50107) Complii 1025/4 BW HL (JP50108) Complii 1025/2 BW HL (JP50109) Complii 1035/2 BW HL (JP50110) Complii 1210/4 BW HL (JP50118) Complii 1215/4 BW HL (JP50119) Complii 1225/4 BW HL (JP50120) Complii 1225/2 BW HL (JP50121) Complii 1235/2 BW HL (JP50122)	Réaction au feu ÉTANCHÉITÉ À L'EAU, ÉTANCHÉITÉ À L'AIR - Étanchéité à l'eau - Étanchéité aux odeurs EFFICACITÉ (PERFORMANCE DE RELEVAGE) - Refoulement de matières solides - Raccords de tuyaux - Dimensions minimales des conduites d'aération - Débit minimum - Passage libre minimal de l'installation - Volume utile minimal RÉSTANCE MÉCANIQUE - Capacité de charge et stabilité structurelle du collecteur pour une utilisation à l'extérieur des bâtiments - Stabilité structurelle du collecteur pour une utilisation à l'intérieur des bâtiments NIVEAU SONORE RÉSTANCE - de la stabilité structurelle - de la performance de relevage - de la résistance mécanique SUBSTANCES DANGEREUSES
--	--	---	--

 0197	JUNG PUMPEN GmbH - Industriestr. 4-6 33803 Steinhagen, Germany 20 466.12.2022.10	EN 12050-1:2001; 2015 Lifting plant for wastewater containing faecal matter Complii 1215/4 HL GB 15M (JP50165) Complii 1225/4 HL GB 15M (JP50166) Complii 1210/4 HL GB 15M (JP50737) Complii 1210/4 E HL GB 15M (JP50169) Complii 1210/4 E HL GB (JP50170) Complii 1215/4 BW HL (JP50736) Complii 1225/4 BW HL (JP50738) Complii 1225/2 BW HL (JP50739) Complii 1235/2 BW HL (JP50740)	Réaction au feu WATER TIGHTNESS, AIR TIGHTNESS - Water tightness - Odour tightness EFFECTIVENESS (LIFTING EFFECTIVENESS) - Pumping of solids - Pipe connections - Minimum dimensions of ventilating pipes system - Minimum flow velocity - Minimum free passage of the plant - Minimum useful volume MECHANICAL RESISTANCE - Load bearing capacity and structural stability of collection tank for use outside buildings - Structural stability of collection tank for use inside buildings NOISE LEVEL DURABILITY - of structural stability - of lifting effectiveness - of mechanical resistance DANGEROUS SUBSTANCES
--	--	--	--

 0197	JUNG PUMPEN GmbH - Industriestr. 4-6 33803 Steinhagen, Germany 20 466.12.2022.10	EN 12050-1:2001; 2015 Fäkalienhebeanlage Complii 1010/4 BWE HL (JP50105) Complii 1010/4 BW HL (JP50106) Complii 1015/4 BW HL (JP50107) Complii 1025/4 BW HL (JP50108) Complii 1025/2 BW HL (JP50109) Complii 1035/2 BW HL (JP50110) Complii 1210/4 BW HL (JP50118) Complii 1215/4 BW HL (JP50119) Complii 1225/4 BW HL (JP50120) Complii 1225/2 BW HL (JP50121) Complii 1235/2 BW HL (JP50122)	BRANDVERHALTEN WASSERDICHTHEIT, LUFTDICHTHEIT - Wasserdichtheit - Geruchsichtheit WIRKSAMKEIT (HEBEWIRKUNG) - Förderung von Feststoffen - Rohranschlüsse - Mindestmaße von Lüftungsleitungen - Mindestfließgeschwindigkeit - Freier Mindestdurchgang der Anlage - Mindestnutzvolumen MECHANISCHE FESTIGKEIT - Tragfähigkeit und strukturelle Stabilität des Sammelbehälters für die Verwendung außerhalb von Gebäuden - Strukturelle Stabilität des Sammelbehälters für die Verwendung innerhalb von Gebäuden GERÄUSCHPEGEL DAUERHAFTIGKEIT - der Wasserdichtheit und Luftdichtheit - der Hebewirkung - der mechanischen Festigkeit GEFÄHRLICHE SUBSTANZEN
--	--	--	---

 0197 JUNG PUMPEN GmbH - Industriestr. 4-6 33803 Steinhagen, Germany 20 466.12.2022.10	EN 12050-1:2001; 2015 Instalacja przepompowni fekaliiów Compli 1010/4 BWE HL (JP50105) Compli 1010/4 BW HL (JP50106) Compli 1015/4 BW HL (JP50107) Compli 1025/4 BW HL (JP50108) Compli 1025/2 BW HL (JP50109) Compli 1035/2 BW HL (JP50110) Compli 1210/4 BW HL (JP50118) Compli 1215/4 BW HL (JP50119) Compli 1225/4 BW HL (JP50120) Compli 1225/2 BW HL (JP50121) Compli 1235/2 BW HL (JP50122)	 0197 JUNG PUMPEN GmbH - Industriestr. 4-6 33803 Steinhagen, Germany 20 466.12.2022.10 EN 12050-1:2001; 2015 Stazione di sollevamento per acque reflue contenenti materiale fecale Compli 1010/4 BWE HL (JP50105) Compli 1010/4 BW HL (JP50106) Compli 1015/4 BW HL (JP50107) Compli 1025/4 BW HL (JP50108) Compli 1025/2 BW HL (JP50109) Compli 1035/2 BW HL (JP50110) Compli 1210/4 BW HL (JP50118) Compli 1215/4 BW HL (JP50119) Compli 1225/4 BW HL (JP50120) Compli 1225/2 BW HL (JP50121) Compli 1235/2 BW HL (JP50122)
 0197 JUNG PUMPEN GmbH - Industriestr. 4-6 33803 Steinhagen, Germany 20 466.12.2022.10	EN 12050-1:2001; 2015 Fecaliëpompinstallatie Compli 1010/4 BWE HL (JP50105) Compli 1010/4 BW HL (JP50106) Compli 1015/4 BW HL (JP50107) Compli 1025/4 BW HL (JP50108) Compli 1025/2 BW HL (JP50109) Compli 1035/2 BW HL (JP50110) Compli 1210/4 BW HL (JP50118) Compli 1215/4 BW HL (JP50119) Compli 1225/4 BW HL (JP50120) Compli 1225/2 BW HL (JP50121) Compli 1235/2 BW HL (JP50122)	 0197 JUNG PUMPEN GmbH - Industriestr. 4-6 33803 Steinhagen, Germany 20 466.12.2022.10 EN 12050-1:2001; 2015 Fecaliëpompinstallatie Compli 1010/4 BWE HL (JP50105) Compli 1010/4 BW HL (JP50106) Compli 1015/4 BW HL (JP50107) Compli 1025/4 BW HL (JP50108) Compli 1025/2 BW HL (JP50109) Compli 1035/2 BW HL (JP50110) Compli 1210/4 BW HL (JP50118) Compli 1215/4 BW HL (JP50119) Compli 1225/4 BW HL (JP50120) Compli 1225/2 BW HL (JP50121) Compli 1235/2 BW HL (JP50122)
 0197 JUNG PUMPEN GmbH - Industriestr. 4-6 33803 Steinhagen, Germany 20 466.12.2022.10	EN 12050-1:2001; 2015 Fecaliëpompinstallatie Compli 1010/4 BWE HL (JP50105) Compli 1010/4 BW HL (JP50106) Compli 1015/4 BW HL (JP50107) Compli 1025/4 BW HL (JP50108) Compli 1025/2 BW HL (JP50109) Compli 1035/2 BW HL (JP50110) Compli 1210/4 BW HL (JP50118) Compli 1215/4 BW HL (JP50119) Compli 1225/4 BW HL (JP50120) Compli 1225/2 BW HL (JP50121) Compli 1235/2 BW HL (JP50122)	 0197 JUNG PUMPEN GmbH - Industriestr. 4-6 33803 Steinhagen, Germany 20 466.12.2022.10 EN 12050-1:2001; 2015 Fecaliëpompinstallatie Compli 1010/4 BWE HL (JP50105) Compli 1010/4 BW HL (JP50106) Compli 1015/4 BW HL (JP50107) Compli 1025/4 BW HL (JP50108) Compli 1025/2 BW HL (JP50109) Compli 1035/2 BW HL (JP50110) Compli 1210/4 BW HL (JP50118) Compli 1215/4 BW HL (JP50119) Compli 1225/4 BW HL (JP50120) Compli 1225/2 BW HL (JP50121) Compli 1235/2 BW HL (JP50122)

EU-Konformitätserklärung
EU-Prohlášení o shodě
EU-Overensstemmelseserklæring
EU-Declaration of Conformity
EU-Vaatumustenmukaisuusvakuutus

EU-Déclaration de Conformité
EU-Megfelelőségi nyilatkozat
EU-Dichiarazione di conformità
EU-Conformiteitsverklaring
EU-Deklaracja zgodności

EU-Declaração de Conformidade
EU-Declarație de conformitate
EU-Vyhlasenie o zhode
EU-Försäkran om överensstämmelse

DE - Richtlinien - Harmonisierte Normen
CS - Směrnice - Harmonizované normy
DA - Direktiv - Harmoniseret standard
EN - Directives - Harmonised standards
FI - Direktiivi - Yhdenmukaistettu standardi

FR - Directives - Normes harmonisées
HU - Irányelve - Harmonizált szabványok
IT - Direttive - Norme armonizzate
NL - Richtlijnen - Geharmoniseerde normen
PL - Dyrektywy - Normy zharmonizowane

PT - Directiva - Normas harmonizadas
RO - Directivă - Norme coroborate
SK - Smernice - Harmonizované normy
SV - Direktiv - Harmoniserade normer

- 2006/42/EG (MD) EN 809:1998/AC:2010, EN ISO 12100:2010, EN 60335-1:2012/A13:2017
- 2011/65/EU (RoHS)
- 2014/30/EU (EMC) EN 55014-1:2017/A11:2020, EN 55014-2:1997/A2:2008, EN 60034-1: 2010/AC: 2010, EN 61000-3-2:2014, EN 61000-3-3:2013
- 2014/34/EU (ATEX) EN 1127-1:2019

JUNG PUMPEN GmbH - Industriestr. 4-6 - 33803 Steinhagen - Germany - www.jung-pumpen.de

DE - Wir erklären in alleiniger Verantwortung, dass das Produkt den aufgeführten Richtlinien entspricht.
CS - Prohlašujeme na svou výlučnou odpovědnost, že výrobek odpovídá jmenovaným směrnici.
DA - Vi erklærer under ansvar at produktet i overensstemmelse med de retningslinjer
EN - We hereby declare, under our sole responsibility, that the product is in accordance with the specified Directives.
FI - Me vakuutamme omalla vastuullamme, että tuote täyttää ohjeita.
FR - Nous déclarons sous notre propre responsabilité que le produit répond aux directives.
HU - Kizárólagos felelősségünk tudatában kijelentjük, hogy ez a termék megfelel az Európai Unió fentnevezett irányelveinek.
IT - Noi dichiariamo sotto la nostra esclusiva responsabilità che il prodotto è conforme alle direttive citate
NL - Wij verklaren geheel onder eigen verantwoordelijkheid dat het product voldoet aan de gestelde richtlijnen.
PL - Z pełną odpowiedzialnością oświadczamy, że produkt odpowiada postanowieniom wymienionych dyrektyw.
PT - Declaramos, sob nossa exclusiva responsabilidade, que o produto está em conformidade com as Diretivas especificadas.
RO - Declarăm pe proprie răspundere că produsul corespunde normelor prevăzute de directivele mai sus menționate.
SK - Na výlučnú zodpovednosť vyhlasujeme, že výrobok spĺňa požiadavky uvedených smerníc.
SV - Vi försäkrar att produkten på vårt ansvar är utförd enligt gällande riktlinjer.

compli 1010/4 BWE HL (JP50105)
compli 1010/4 BW HL (JP50106)
compli 1015/4 BW HL (JP50107)
compli 1025/4 BW HL (JP50108)
compli 1025/2 BW HL (JP50109)
compli 1035/2 BW HL (JP50110)

compli 1210/4 BW HL (JP50118)
compli 1215/4 BW HL (JP50119)
compli 1225/4 BW HL (JP50120)
compli 1225/2 BW HL (JP50121)
compli 1235/2 BW HL (JP50122)

compli 1525/4 C1 HL (JP50123)
compli 1535/4 C1 HL (JP50124)
compli 1555/4 C5 HL (JP50125)
compli 1575/4 C5 HL (JP50126)
compli 1575/4 B6 HL (JP50127)
compli 1535/2 B2 HL (JP50128)
compli 1555/2 B2 HL (JP50129)
compli 1575/2 B5 HL (JP50130)
compli 15100/2 B5 HL (JP50131)
compli 15200/2 B6 HL (JP50132)

compli 2525/4 C1 HL (JP50133)
compli 2535/4 C1 HL (JP50134)
compli 2555/4 C5 HL (JP50135)
compli 2575/4 C5 HL (JP50136)
compli 2575/4 B6 HL (JP50137)
compli 2535/2 B2 HL (JP50138)
compli 2555/2 B2 HL (JP50139)
compli 2575/2 B5 HL (JP50140)
compli 25100/2 B5 HL (JP50141)
compli 25200/2 B6 HL (JP50142)

DE-Weitere normative Dokumente CS-Jinými normativními dokumenty DA-Andre normative dokumenter EN-Other normative documents FI-Muiden normien FR-Autres documents normatifs HU-Egyéb szabályozó dokumentumokban leírtaknak IT-Altri documenti normativi NL-Verdere normatieve documenten PL-Innymi dokumentami normatywnymi PT-Outros documentos normativos RO-Alte acte normative SK-Iným závazným dokumentom SV-Vidare normerande dokument:

EN 60335-2-41:2021/A11:2021
TRGS 727

DE-Bevollmächtigter für technische Dokumentation CS-Oprávněná osoba pro technickou dokumentaci DA-utoriseret person for teknisk dokumentation EN-Authorized person for technical documentation FI-Valtuutettu henkilö tekninen dokumentaatio FR-Personne autorisée à la documentation technique HU-Hivatalos személy műszaki dokumentáció IT-Persona abilitata per la documentazione tecnica NL-Bevoegd persoon voor technische documentatie PL-Pełnomocnik ds. dokumentacji technicznej PT-Pessoa autorizada para documentação técnica RO-Persoană autorizată pentru documentație tehnică SK-Oprávněná osoba pre technickú dokumentáciu SV-Auktoriserad person för teknisk dokumentation:

JUNG PUMPEN - Stefan Sirges - Industriestr. 4-6 - 33803 Steinhagen

Steinhagen, 20-10-2022

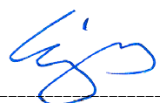
Stefan Sirges, General Manager

i.V. Pascal Köllebeck, Sales Manager



UKCA-Declaration of Conformity

Legislation - Designated Standards

- **Supply of Machinery (Safety) Regulations 2008 (MD)** EN 809:1998/AC:2010, EN ISO 12100:2010, EN 60335-1:2012/A13:2017
- **The Restriction of the Use of Certain Hazardous Substance in Electrical and Electronic Equipment Regulations 2012 (RoHS)**
- **Electromagnetic Compatibility Regulations 2016 (EMC)** EN55014-1:2017/A11:2020, EN 55014-2:1997/A2:2008, EN 60034-1: 2010/AC: 2010, EN 61000-3-2:2014, EN 61000-3-3:2013

Name and address of the manufacturer: JUNG PUMPEN GmbH - Industriestr. 4-6 - 33803 Steinhagen - Germany - www.jung-pumpen.de

We hereby declare, under our sole responsibility, that the product is in accordance with the specified Legislation.

Compli 1215/4 HL GB 15M (JP50165)
Compli 1225/4 HL GB 15M (JP50166)
Compli 1210/4 HL GB 15M (JP50737)
Compli 1210/4 E HL GB 15M (JP50169)
Compli 1210/4 E HL GB (JP50170)
Compli 1215/4 BW HL (JP50736)
Compli 1225/4 BW HL (JP50738)
Compli 1225/2 BW HL (JP50739)
Compli 1235/2 BW HL (JP50740)

Compli 1525/4 C1 HL (JP50741)
Compli 1535/4 C1 HL (JP50742)
Compli 1555/4 C5 HL (JP50743)
Compli 1575/4 C5 HL (JP50744)
Compli 1575/4 B6 HL (JP50745)
Compli 1535/2 B2 HL (JP50746)
Compli 1555/2 B2 HL (JP50747)
Compli 1555/2 B2 HL (JP50748)

Compli 15100/2 B5 HL (JP50749)
Compli 15200/2 B6 HL (JP50750)
Compli 2525/4 C1 HL (JP50751)
Compli 2535/4 C1 HL (JP50752)
Compli 2555/4 C5 HL (JP50753)
Compli 2575/4 C5 HL (JP50754)
Compli 2575/4 B6 HL (JP50755)
Compli 2535/2 B2 HL (JP50756)
Compli 2555/2 B2 HL (JP50757)
Compli 2575/2 B5 HL (JP50758)
Compli 25100/2 B5 HL (JP50759)
Compli 25200/2 B6 HL (JP50760)

Other normative documents:

EN 60335-2-41:2003/A2:2010

Authorized person for technical documentation

JUNG PUMPEN - Stefan Sirges - Industriestr. 4-6 - 33804 Steinhagen
Steinhagen, 20-10-2022



Stefan Sirges, General Manager

i.V. -----
Pascal Kölkebeck, Sales Manager

Technische Daten - Technical data - Caractéristiques techniques - Technische Gegevens - Dati tecnici - Dane techniczne

	... 1010/4 BWE	... 1010/4 BW ... 1210/4 BW	... 1015/4 BW ... 1215/4 BW	... 1025/4 BW ... 1225/4 BW	... 1025/2 BW ... 1225/2 BW	... 1035/2 BW ... 1235/2 BW
[kg]	118	128/145	128/145	128/145	125/149	132/158
 PN 10 [mm]	DN 80 70	DN 80 70	DN 80 70	DN 80 70	DN 80 70	DN 80 70
S3* / Tmax [°C]	25 % / 40	30 % / 40	30 % / 40	15 % / 40	25 % / 40	25 % / 40
P1 [kW]	1,55	1,25	2,2	3,0	3,3	4,8
P2 [kW]	1,10	0,87	1,7	2,2	2,6	4,0
U [V]	1/N/PE ~230	3/N/PE ~400	3/N/PE ~400	3/N/PE ~400	3/N/PE ~400	3/N/PE ~400
f [Hz]	50	50	50	50	50	50
I [A]	7,1	2,8	3,9	5,1	5,4	7,8
n [min ⁻¹]	1428	1451	1405	1363	2807	2857
	HL 2-610ECP	Highlogo 2-25 P	Highlogo 2-25 P	Highlogo 2-46 P	Highlogo 2-46 P	Highlogo 2-610 P

* Beispiel: 40% = 4 min Betrieb + 6 min Pause (Spieldauer 10 min)

Example for 40%: 4 min. operation and 6 min. rest (Cycle duration 10 min.);

Esempio: 40%: 4 min. di funzionamento + 6 min. di pausa (durata del ciclo 10 min.)

Exemple: 40% = 4 min de service et 6 min de pause (Durée du jeu 10 min)

Przykładowo 40%: 4 min pracy i 6 min przerwy (Czas cyklu 10 min);

Leistung - Performance - Puissances - Capaciteit - Prestazioni - Wydajności i moce

H [m]	1	2	3	4	5	6	7	8	9	10	11	12	13	14	15	16	17
	Q [m³/h]																
1010 BWE	48	40	33	27	20	10											
... 10/4 BW	48	40	33	27	20	10											
... 15/4 BW	69	62	56	49	42	36	27	19									
... 25/4 BW					56	49	42	32	22	13							
... 25/2 BW	69	64	58	52	47	42	37	33	28	23	20	14	8	1			
... 35/2 BW	85	80	75	71	66	62	57	54	50	47	44	39	36	33	30	26	21

Compli 1000

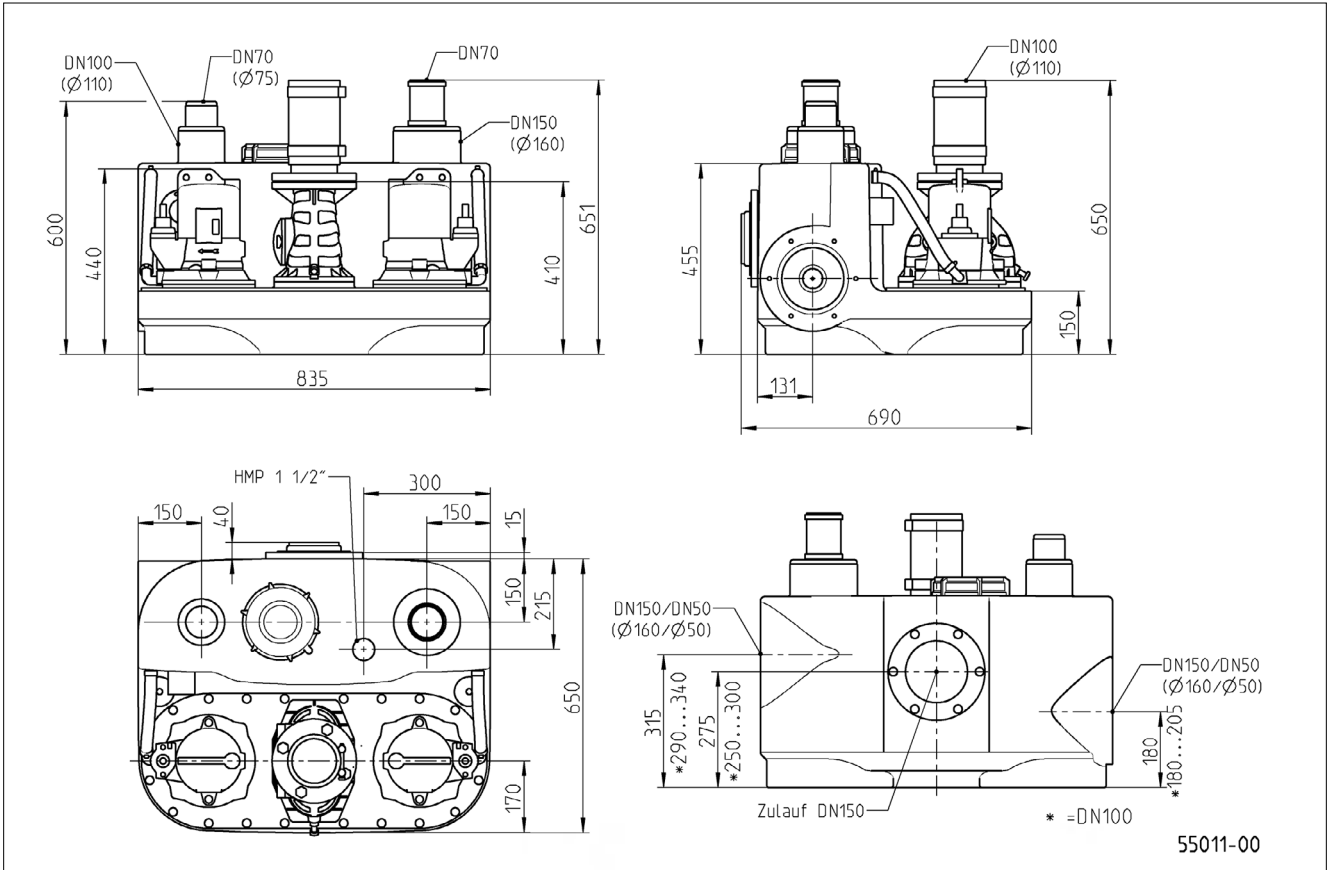

Compli 1200

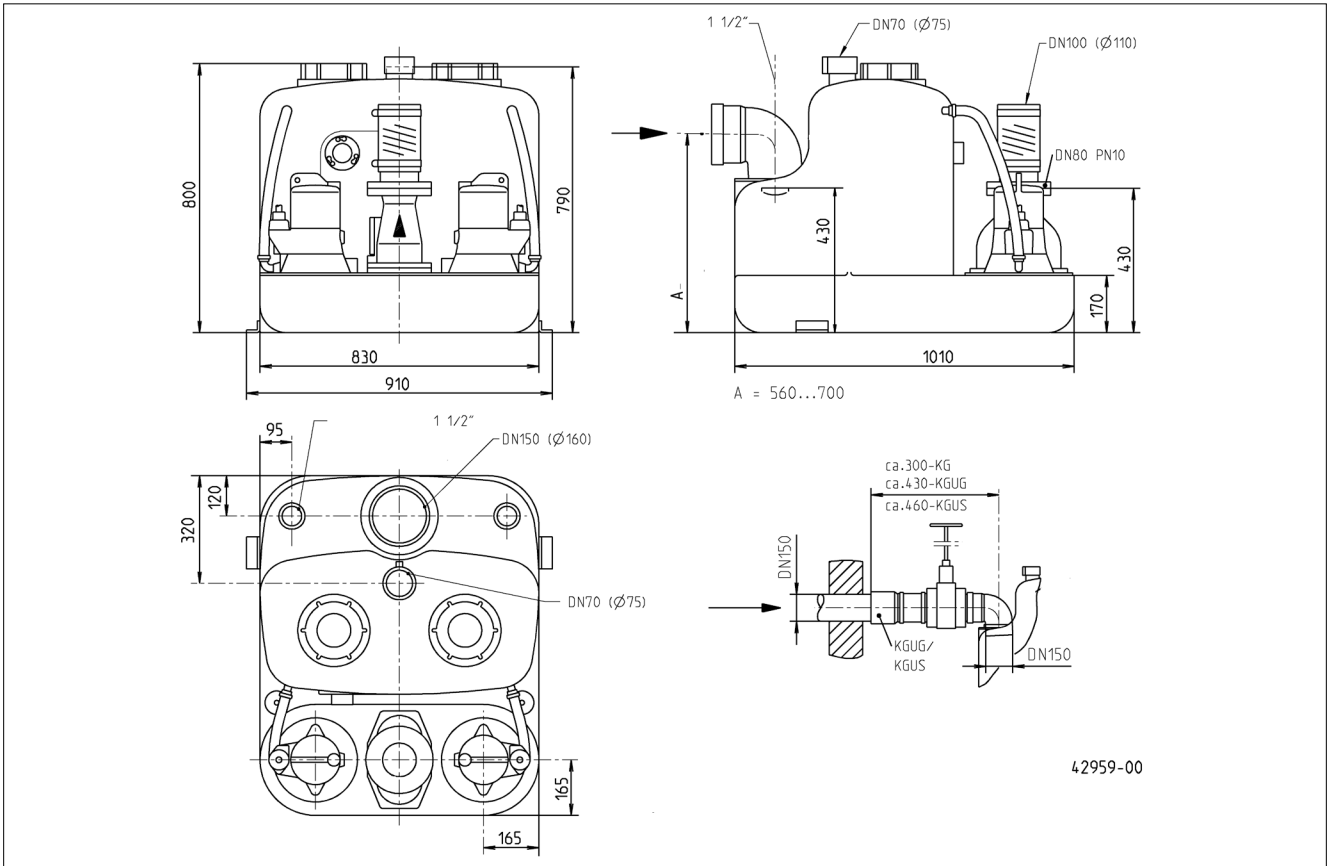

Compli Sensor

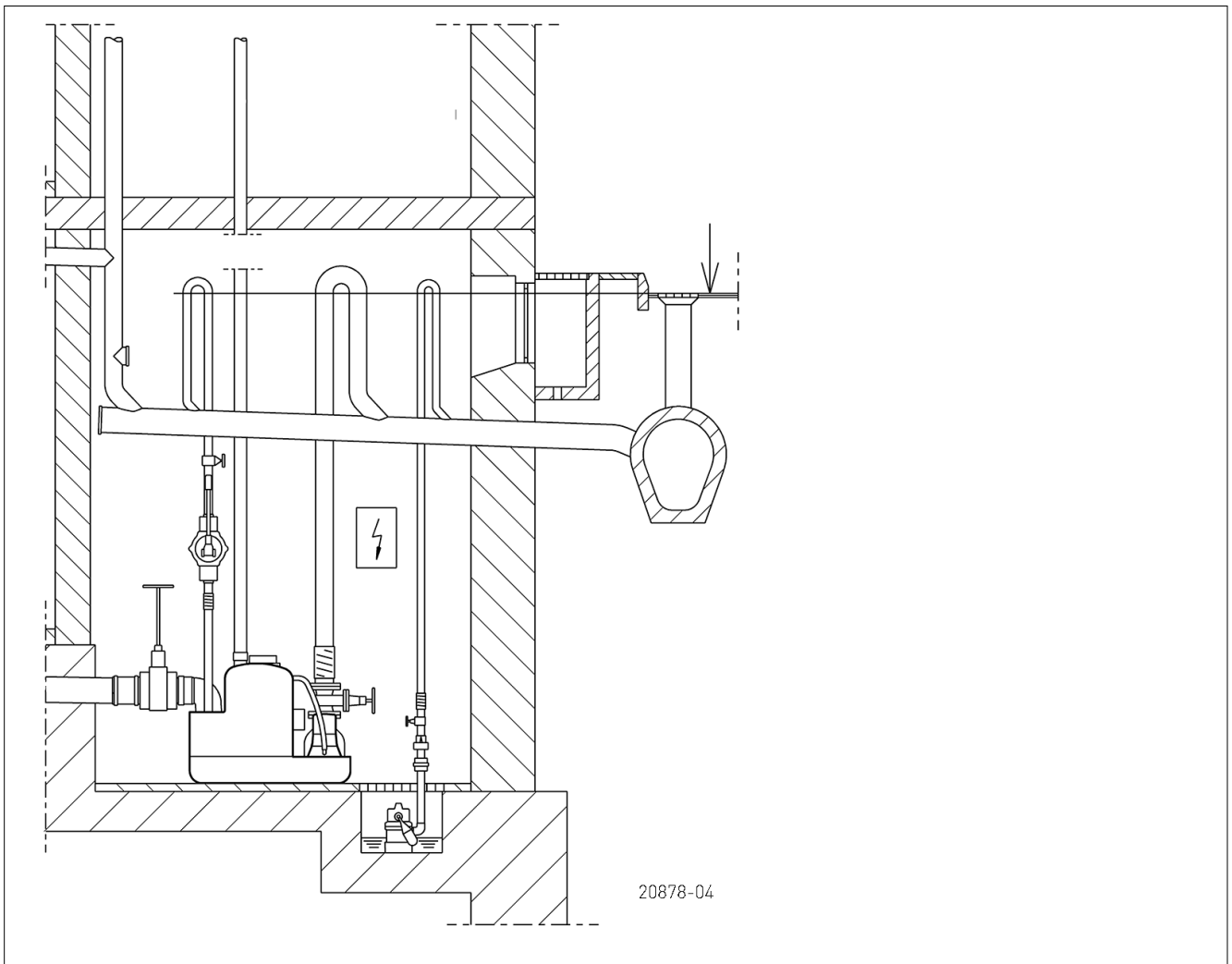
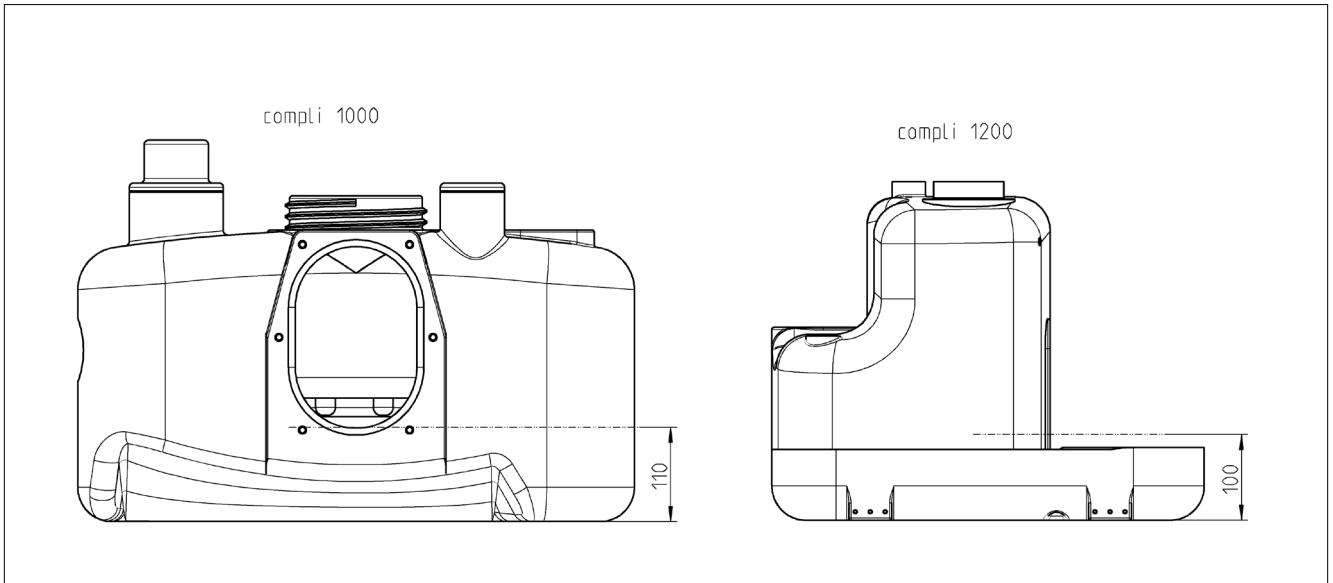

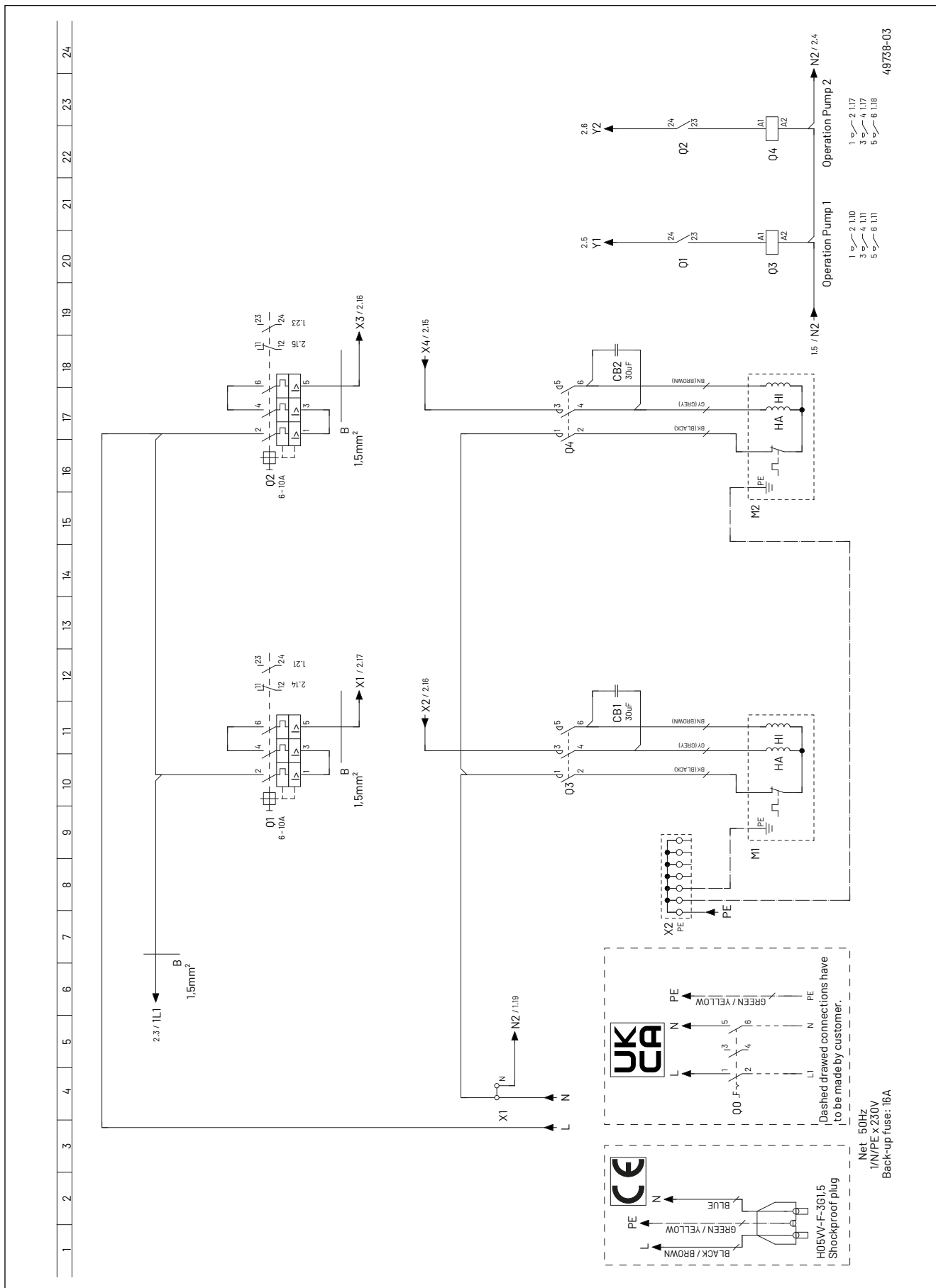

49738-03

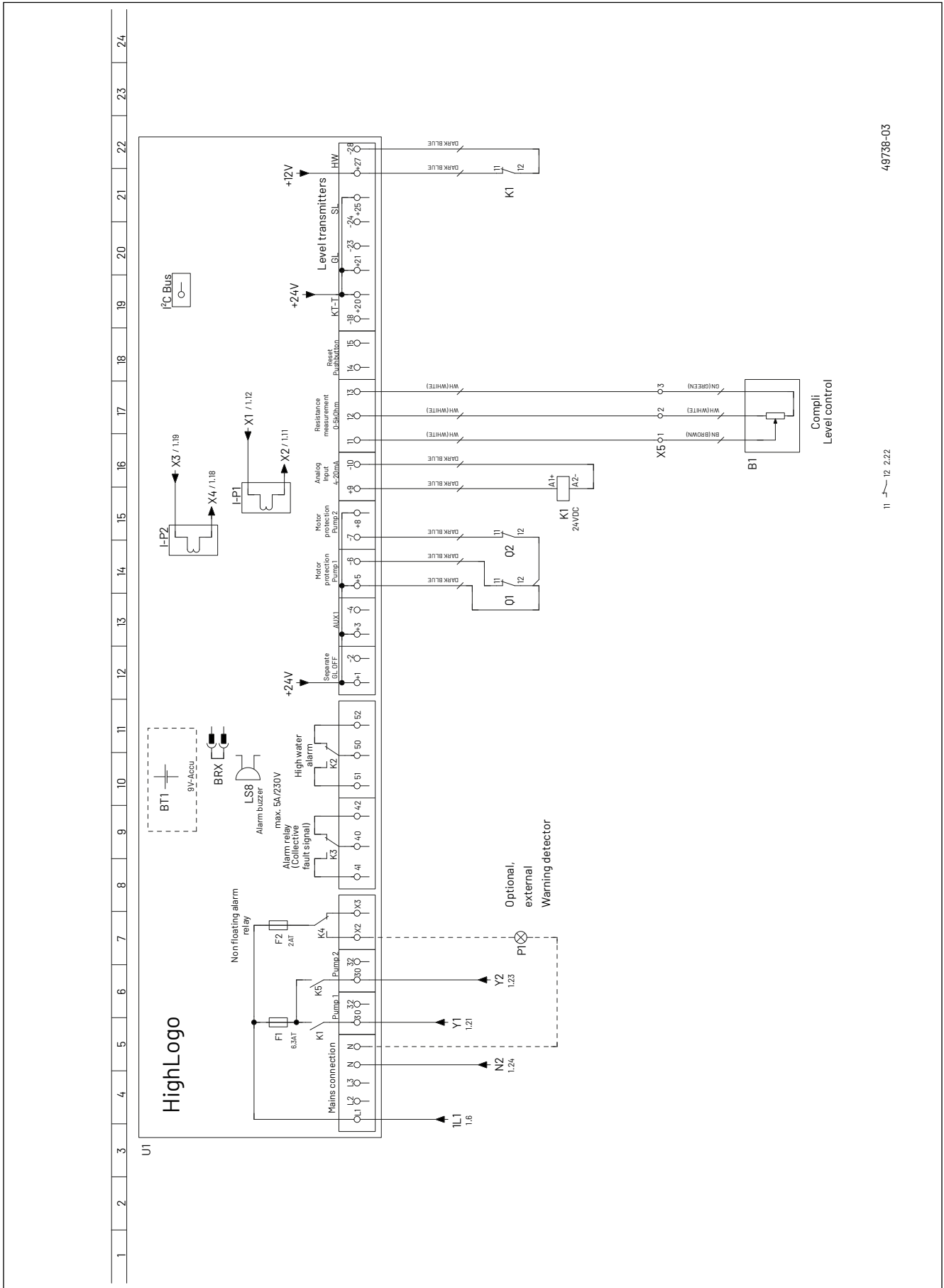

49738-03

11 12 2.22

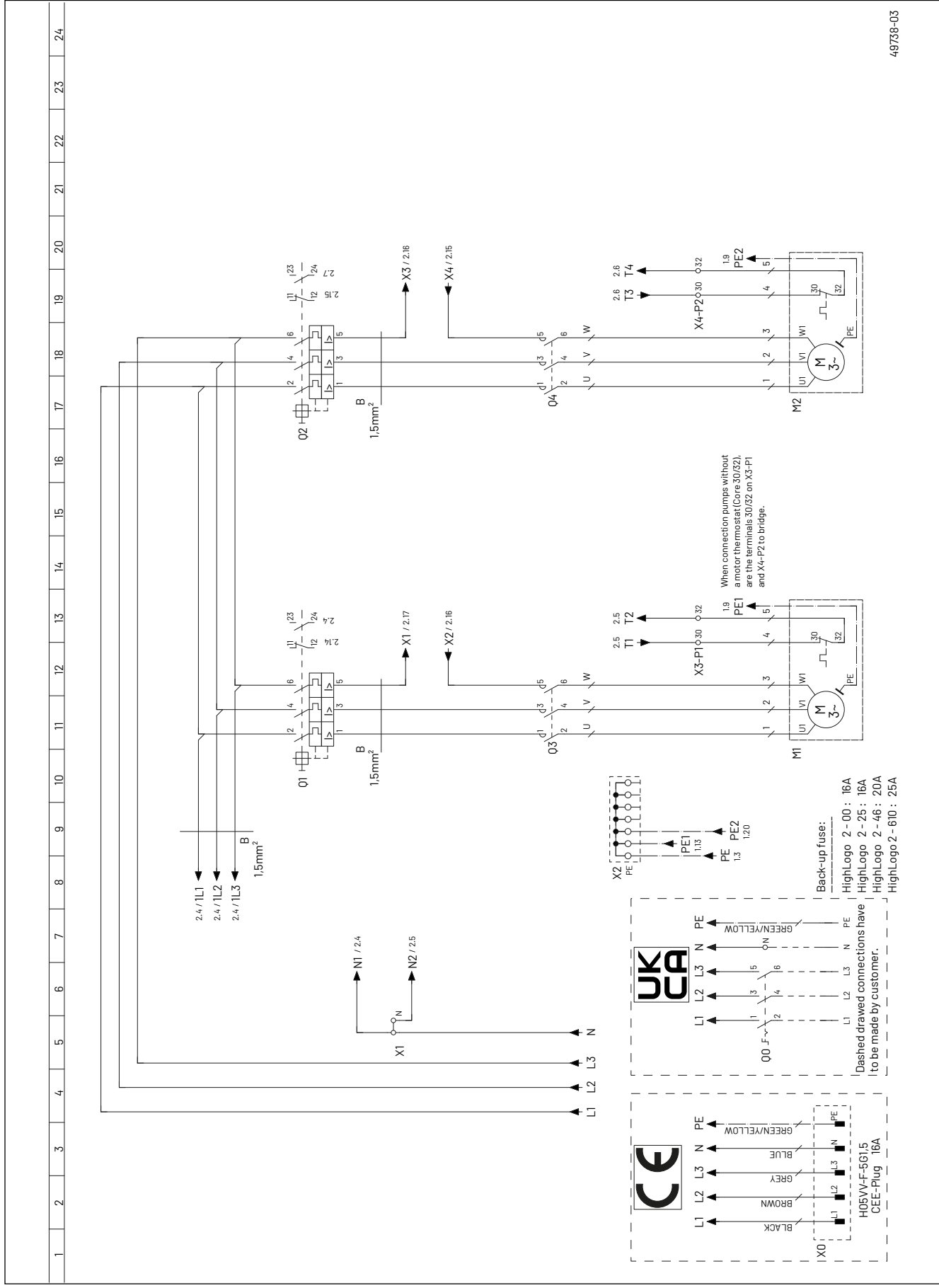

49735-03

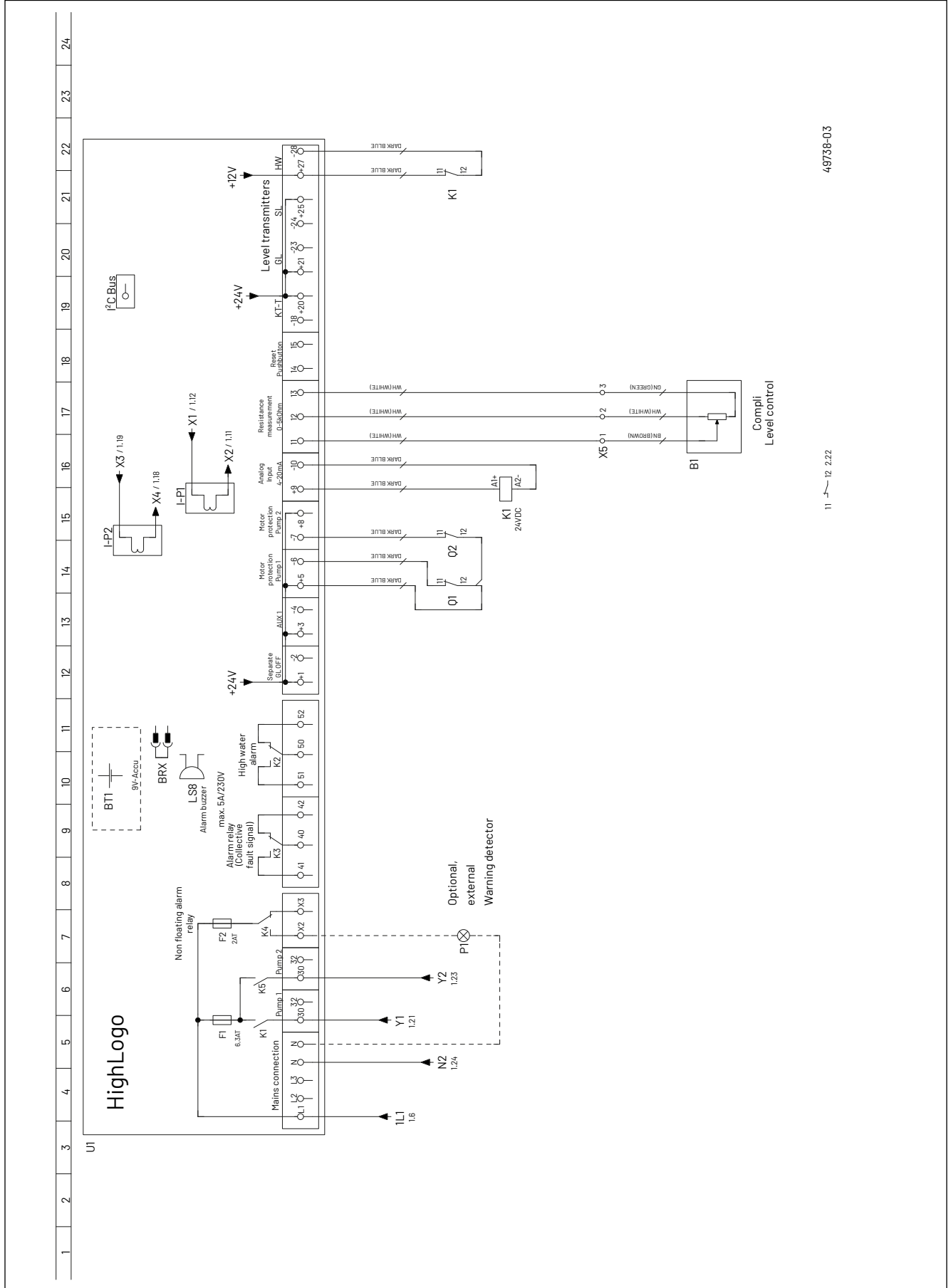

49738-03

11 12 2.2.2



①	Niveauerfassung 4 m 15 m	Level control	JP43712 JP48227
②	Dichtung Niveauerfassung	Seal level control	JP50479
③	Adapter	Adaper	JP50478
④	Steuerung HighLogo 2-610ECP (1010/4 BWE) HighLogo 2-25P (1010/4, 1015/4) HighLogo 2-46P (1025/4, 1025/2) HighLogo 2-610P (1035/2)	Control unit	JP50509 JP50510 JP50511 JP50512
⑤	Elastische Verbindung	Elastic connector	JP43705
⑥	Flansch	Flange	JP43706
⑦	HighLogo 2, Platine HighLogo 2, Tür-Set Leistungsschütz DILMT9 Hilfssch.Baustein 11 DILT-XH11	HighLogo 2, PCBA HighLogo 2, Door-Set Contactor DILMT9 Auxiliary switch 1 1 DILT-XH11	JP50176 JP48147 JP50518 JP50519
⑧	Pumpe ...10/4 BWE, 4 m ...10/4 BWE, 15 m ...10/4 ...15/4 ...25/4 ...25/2 ...35/2 ...10/4, 15M ...15/4, 15M ...25/4,15M	Pump	JP50470 JP50584 JP50469 JP48824 JP48825 JP48826 JP48827 JP50162 JP50163 JP50164
⑨	Rückschlagklappe	Reflux valve	JP50566
⑩	Reduzierstück DN 150/DN 100	Reducer DN 150/DN 100	JP48871
⑪	Doppelklappe	Double flap	JP46812
⑫	Klemmflansch	Clamping flange	JP43713
⑬	Basisplatte	Base plate	JP43714
⑭	Pumpenlüftung	Pump ventilation	JP43710
⑮	Dichtband	Sealing tape	JP47966
⑯	Wartungsdeckel	Service lid	JP42798
⑰	Steckdichtung D50xD59	Plug-in connection D50xD59	JP45099
⑱	Überschiebmuffe	Collar	JP47287
⑲	Auftriebssicherung	Anti floating	JP43709
⑳	Behälter	Tank	JP44861

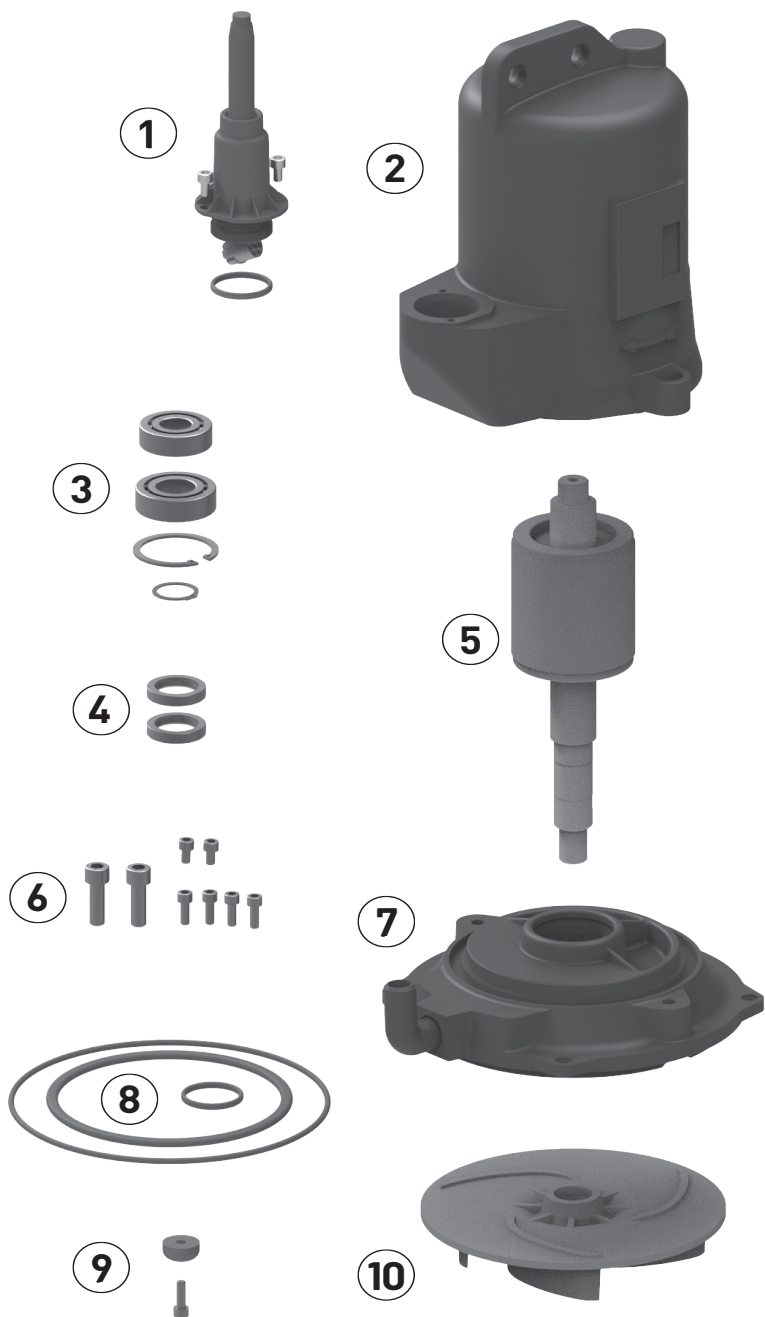

①	Leitung	Cable	
	10/4, 15/4, 25/4, 4 m		JP50485
	10/4, 15/4, 25/4, 15 m		JP50161
	1010/4 BWE, 4 m		JP50486
	1010/4 BWE, 15 m		JP50487
②	Stator + Gehäuse	Stator + Housing	
	10/4		JP50488
	15/4, 25/4		JP50447
	1010/4 BWE		JP50448
③	Lagersatz	Bearing set	JP46724
④	Motorabdichtung	Motor seals	JP46806
⑤	Rotorwelle	Rotor shaft	
	10/4		JP46761
	15/4, 25/4		JP50322
	1010/4 BWE		JP46801
⑥	Schraubensatz	Screw set	JP50450
⑦	Lagerschild	Bearing housing	JP43720
⑧	Dichtungssatz	Seal set	JP50449
⑨	Laufadschraube	Impeller screw	JP46803
⑩	Laufad	Impeller	
	10/4		JP47290
	15/4		JP50320
	25/4		JP50321
	1010/4 BWE		JP47290

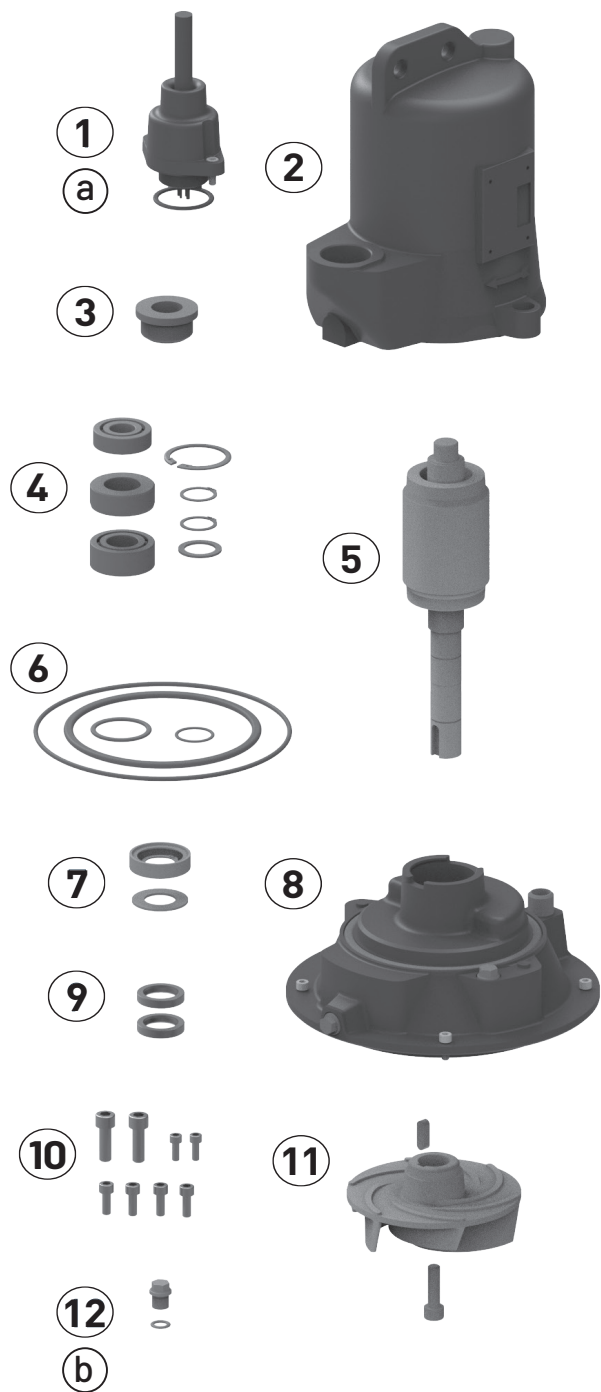

①	Leitung	Cable	JP43717
②	Stator + Gehäuse	Stator + Housing	
	25/2		JP44008
	35/2		JP46211
③	Gleitringdichtung	Mechanical seal	JP46567
④	Lagersatz	Bearing set	JP46214
⑤	Rotorwelle	Rotor shaft	
	25/2		JP48339
	35/2		JP48340
⑥	Dichtungssatz	Seal set	JP46807
⑦	Wellenabdeckung	Shaft cover	JP47043
⑧	Lagerschild	Bearing housing	JP43726
⑨	Motorabdichtung	Motor seals	JP46806
⑩	Schraubensatz	Screw set	JP47291
⑪	Lauftrad	Impeller	
	25/2		JP48359
	35/2		JP48360
⑫	Ölschraube	Oil screw	JP46046

a	10x O-Ring 38x3,5	JP48109
b	10x O-Ring 10x2,5	JP48088

COMPLI 1200 HL

Ersatzteile - Spare parts - Pièces de rechange - Reserveonderdelen - Parti di ricambio - Reservedele - Reservdelar
 Varaoasat - Części zamienne - Náhradní díly - Alkatrészek - Piese de schimb - Запасные части - 备件

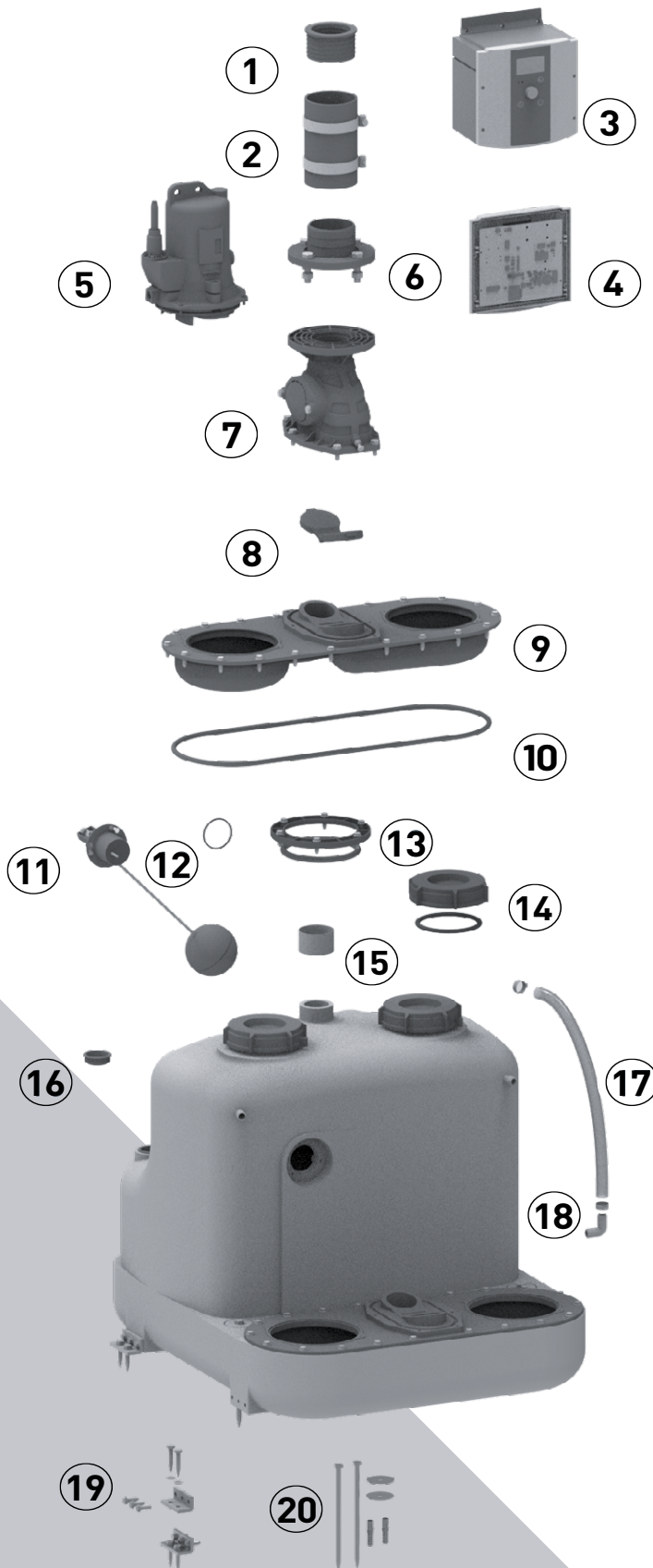

①	Adaper	Adapter	JP50478
②	Elast. Verbindung	Elastic connector	JP43705
③	Steuerung	Control unit	
	HighLogo 2-25P (1210/4, 1215/4)		JP50510
	HighLogo 2-46P (1225/2, 1225/4)		JP50511
	HighLogo 2-610P (1235/2)		JP50512
④	HighLogo 2, Tür-Set	HighLogo 2, Door-Set	JP48147
	Leistungsschutz DILMT9	Contactora DILMT9	JP50518
⑤	Pumpe	Pump	
	...10/4		JP50469
	...10/4 BWE, 4 m		JP50470
	...10/4 BWE, 15 m		JP50584
	...15/4		JP48824
	...25/4		JP48825
	...25/2		JP48826
	...35/2		JP48827
	...10/4, 15M		JP50162
	...15/4, 15M		JP50163
	...25/4,15M		JP50164
⑥	Flansch	Flange	JP43706
⑦	Rückschlagklappe	Reflux valve	JP50566
⑧	Doppelklappe	Duplex flap	JP46812
⑨	Basisplatte	Base plate	JP43714
⑩	Dichtband	Sealing tape	JP47966
⑪	Niveauerfassung	Level control	
	4 m Kabel	4 m Cable	JP47306
	15 m Kabel	15 m Cable	JP50695
⑫	Dichtung Niveauerfassung	Seal level control	JP50479
⑬	Klemmflansch	Clamping flange	JP43713
⑭	Wartungsdeckel	Service lid	JP42798
⑮	Überschiebmuffe	Collar	JP46814
⑯	Steckdichtung D50xD59	Plug-in seal D50xD59	JP45099
⑰	Pumpenlüftung	Pump ventilation	JP43710
⑱	Behälter	Tank	JP44862
⑲	Auftriebssicherung	Anti flooding	JP43716
⑳	Auftriebssicherung	Anti flooding	JP43709

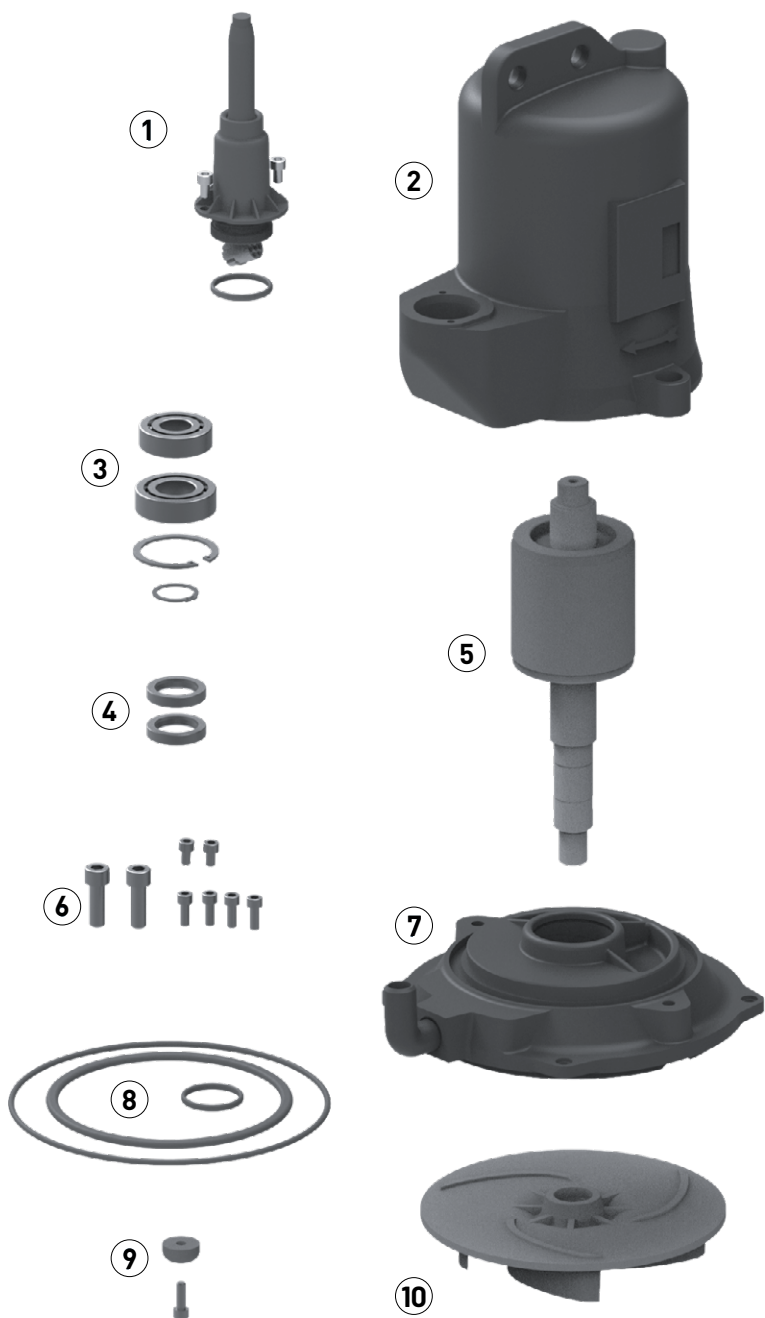

①	Leitung	Cable	
	10/4, 15/4, 25/4, 4 m		JP50485
	10/4, 15/4, 25/4, 15 m		JP50161
	1010/4 BWE, 4 m		JP50486
	1010/4 BWE, 15 m		JP50487
②	Stator + Gehäuse	Stator + Housing	
	10/4		JP50488
	15/4, 25/4		JP50447
	1010/4 BWE		JP50448
③	Lagersatz	Bearing set	JP46724
④	Motorabdichtung	Motor seals	JP46806
⑤	Rotorwelle	Rotor shaft	
	10/4		JP46761
	15/4, 25/4		JP50322
	1010/4 BWE		JP46801
⑥	Schraubensatz	Screw set	JP50450
⑦	Lagerschild	Bearing housing	JP43720
⑧	Dichtungssatz	Seal set	JP50449
⑨	Laufschraube	Impeller screw	JP46803
⑩	Laufrad	Impeller	
	10/4		JP47290
	15/4		JP50320
	25/4		JP50321
	1010/4 BWE		JP47290

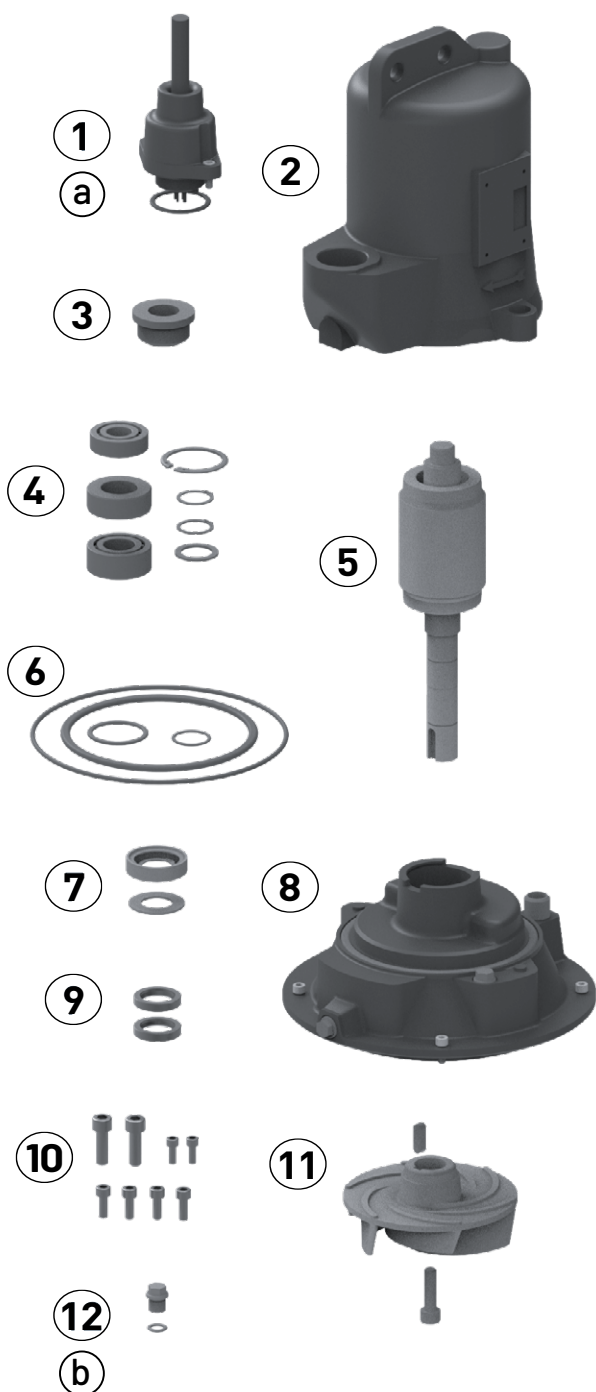

①	Leitung	Cable	JP43717
②	Stator + Gehäuse	Stator + Housing	
	25/2		JP44008
	35/2		JP46211
③	Gleitringdichtung	Mechanical seal	JP46567
④	Lagersatz	Bearing set	JP46214
⑤	Rotorwelle	Rotor shaft	
	25/2		JP48339
	35/2		JP48340
⑥	Dichtungssatz	Seal set	JP46807
⑦	Wellenabdeckung	Shaft cover	JP47043
⑧	Lagerschild	Bearing housing	JP43726
⑨	Motorabdichtung	Motor seals	JP46806
⑩	Schraubensatz	Screw set	JP47291
⑪	Laufblad	Impeller	
	25/2		JP48359
	35/2		JP48360
⑫	Ölschraube	Oil screw	JP46046

a	10x O-Ring 38x3,5	JP48109
b	10x O-Ring 10x2,5	JP48088



**PUMP TECHNICAL
SERVICES LIMITED**



THE SUBMERSIBLE PUMP SPECIALISTS

✉ service@pts-jung.co.uk

✉ sales@pts-jung.co.uk

Pump House
Unit 12
Bilton Road Industrial Estate
Erith, Kent, DA8 2AN

☎ 01322 357 080

🌐 pts-jung.co.uk