

FLUTBOX

DRAINAGE PUMPS

- With powerful submersible drainage pump U5KS
- Pump with cooling jacket for motor housing
- Quick and easy hose connection with C-coupling
- Float fixation for continuous operation
- Wall mounting for storage



DESCRIPTION

The "Flutbox" is a first aid kit for draining basements in an emergency. Just place the pump with its carrying cage on the floor and pump out the water quickly and reliably via the 12.5 m pressure hose (Ø 52 mm). When the float is locked, the pump will continue to operate until the remaining water is 35 mm deep.

The U5KS can be used as a fixed or mobile system, with or without its carrying cage, in the house and garden. If the foot strainer is removed, the free passage of 20 mm can be fully utilised.

PERFORMANCE

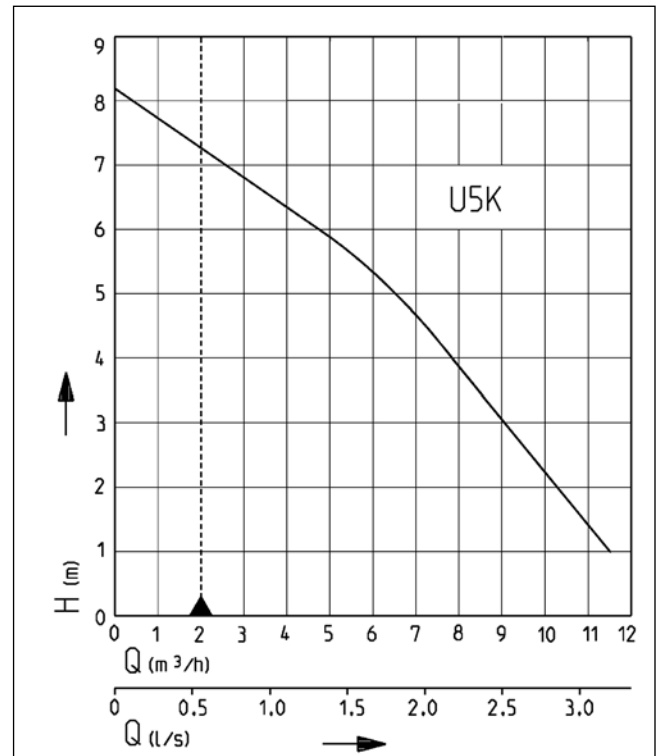

Type	Delivery head H [m]	1	2	3	4	5	6	7
Flutbox	Flow rate Q [m³/h]	11.5	10.5	9.0	7.5	6.5	4.5	2.5

Specifications can be changed without notice. Performance subject to ISO 9906 tolerances. The minimum flow velocity in the pressure piping must be 0.7 m/s according to EN 12056. This data is represented in the performance curve as a limit of application.



FLUTBOX

DRAINAGE PUMPS

SCOPE OF SUPPLY

1 U5KS cellar drainage pump; 1 pressure hose, 12.5 m long, with C coupling (C52); 1 carrying cage with integrated pump fixing; 1 float fixation.

MECHANICAL DATA

Pump	Vertical single-stage	Shaft	Stainless steel
Free passage	20 mm	Impeller	Vortex impeller, GFK
Bearing	Ball bearings, grease-lubricated	Motor housing	Stainless steel
Seal on motor side	Rotary shaft seal	Pump housing	GRP
Oil chamber	Yes	Submersible	Yes
Seal on medium side	2-fold rotary shaft seals	Pressure outlet	C-coupling
Run dry protection	Yes	Weight	11 kg

ELECTRICAL DATA

Circuit	With built-in level control	Wires	3G1,0
Voltage	1/N/PE~230 V	Type of enclosure	IP 68
Motor rating P1	0.52 kW	Insulation class	B
Motor rating P2	0.38 kW	Winding thermostat	Yes
Current	2.3 A	Motor protection	Integrated
Power line	10m H07RN-F	Plug	Safety

FLUTBOX

Type	Code No.
Flutbox	JP09479

Dimensions Flutbox mm

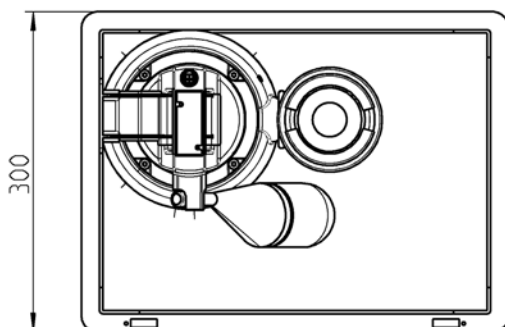
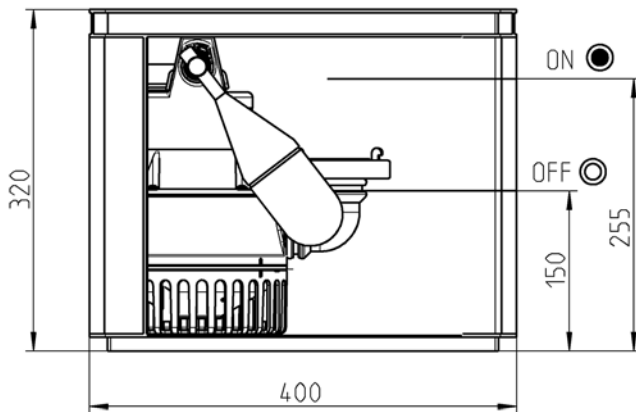

09479-00