

- Direction of pressure drain variable
- Alarm system possible
- Swing-type check valve
- Hot water version resistant up to 176 °F (80 °C)
- Activated carbon filter



DESCRIPTION

The above floor sump Hebefix 100 is a drainage pump station for lifting faeces-free domestic and commercial wastewater up to 104° F (40° C). The tank of Hebefix 100 H version is resistant to wastewater temperatures of up to 176 ° F (80° C). It is a free-standing plastic tank (approx. 75 l) with four combination inlets for pipes with an external diameter of 50 or 110 mm. The pressure pipe enclosed can be passed out of the tank on the left or right side as required (connection R 1½").

The pump to be used can be selected according to the volume of wastewater or as individually required: In case of slightly dirty water (grain size max. 10 mm), pumps U3KS, U5KS as well as

U6K ES+DS can be used. If the admixtures are larger or the volume of wastewater is bigger, the use of a pump of the US series is recommendable. In case of higher wastewater temperatures (commercial use or block of flats), US hot water pumps are used in Hebefix 100 H. Optionally, a special float (see accessories) can be fitted to reduce the on and off switching height as well as the residual volume. In case of commercial applications, the resistance of the materials have to be tested in advance.

Hebefix is ideal for subsequent ground level installation. Without a lot of masonry work or without excavating a pit, Hebefix can be installed at any requested location - even downstream of the backpressure level. Wash basins, washing machines or dish washers as well as a shower tray (only in combination with a U3KS or U6KS with special float) can be connected without any problems.

The connection of a ventilation pipe passed to the roof prevents odours. If the sump is ventilated at the erection site, an activated carbon filter prevents unpleasant smell of Hebefix 100. The installation of an alarm system is recommended. It warns against impermissibly high water levels in the tank.

Specifications can be changed without notice. Performance subject to ISO 9906 tolerances.

PERFORMANCE

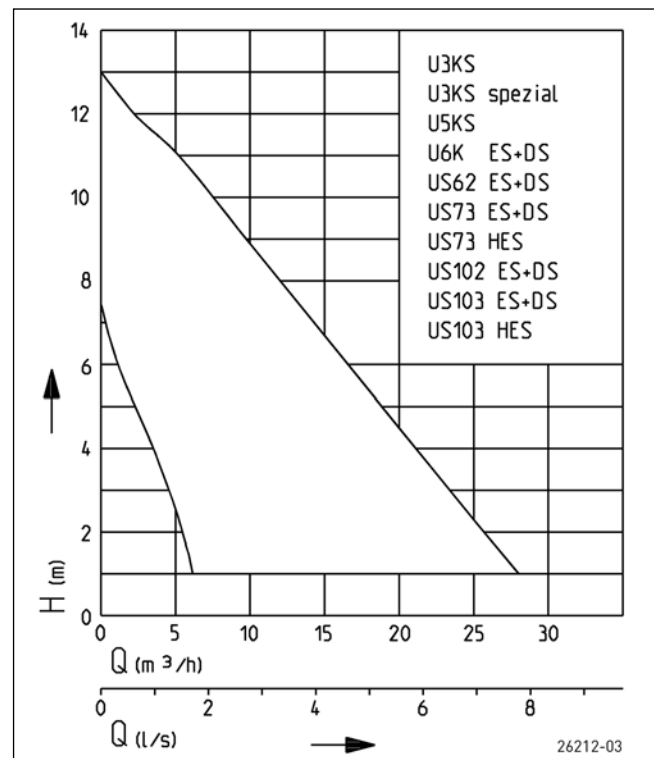

HEBEFIX 100 / 100 H

ABOVE FLOOR TANK

SCOPE OF SUPPLY

Plastic tank to house a pump tested in keeping with German / European standard EN 12050, with seal and cover mounted, four combination inlets, connection sleeve DN 100 with clamps, plug-in seals and elastic connection, tank ventilation, activated

carbon filter (Hebefix 100 only), cable inlet, tank pressure pipe enclosed (made of stainless steel in case of Hebefix 100 H) and swing-type check valve 1/2", (without pump).

MECHANICAL DATA

Tank capacity	75 l
---------------	------

HEBEFIX 100 / 100 H

Type	Code No.	Weight
Hebefix 100	JP09319	8.6 kg
Hebefix 100 H	JP09348	12.3 kg

POSSIBLE PUMPS

Hebefix 100	US 62 ES/DS	Hebefix 100 H
U3KS/U3KS spezial	US 73 ES/DS	US 73 HES
U5KS	US 102 ES/DS	US 103 HES
U6K ES/DS	US 103 ES/DS	

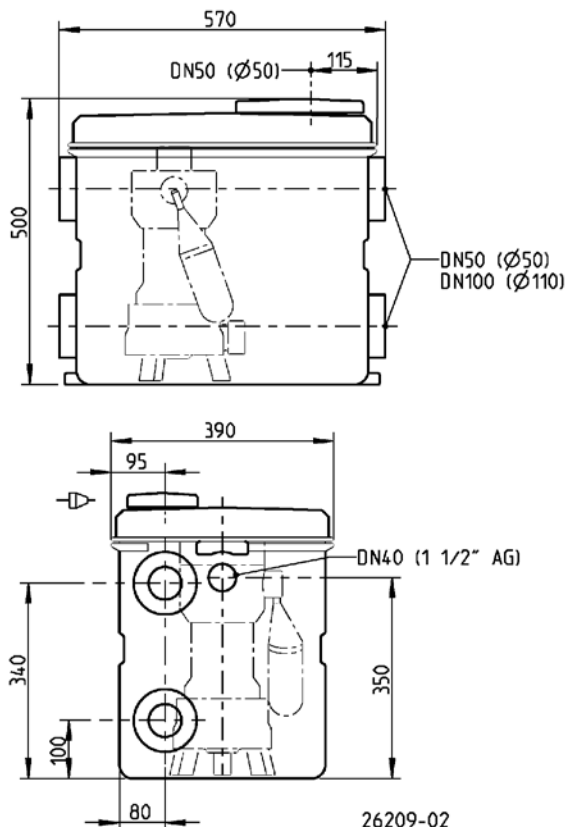

Dimensions Hebefix 100/100 H (mm)



HEBEFIX 100 / 100 H

ABOVE FLOOR TANK

Switching heights

	ON 	OFF	ON 	OFF
U3KS	ca. 220 mm	ca. 115 mm	ca. 110 mm	ca. 50 mm
U5KS	ca. 245 mm	ca. 140 mm	ca. 95 mm	ca. 45 mm
U6KS	ca. 275 mm	ca. 175 mm	ca. 135 mm	ca. 85 mm
US 62 ES/DS	ca. 245 mm	ca. 130 mm	ca. 160 mm	ca. 110 mm
US 73 ES/DS	ca. 245 mm	ca. 130 mm	ca. 160 mm	ca. 110 mm
US 102 ES/DS	ca. 275 mm	ca. 160 mm	ca. 190 mm	ca. 140 mm
US 103 ES/DS	ca. 275 mm	ca. 160 mm	ca. 190 mm	ca. 140 mm

Example of installation Hebefix/Hebefix 100 H

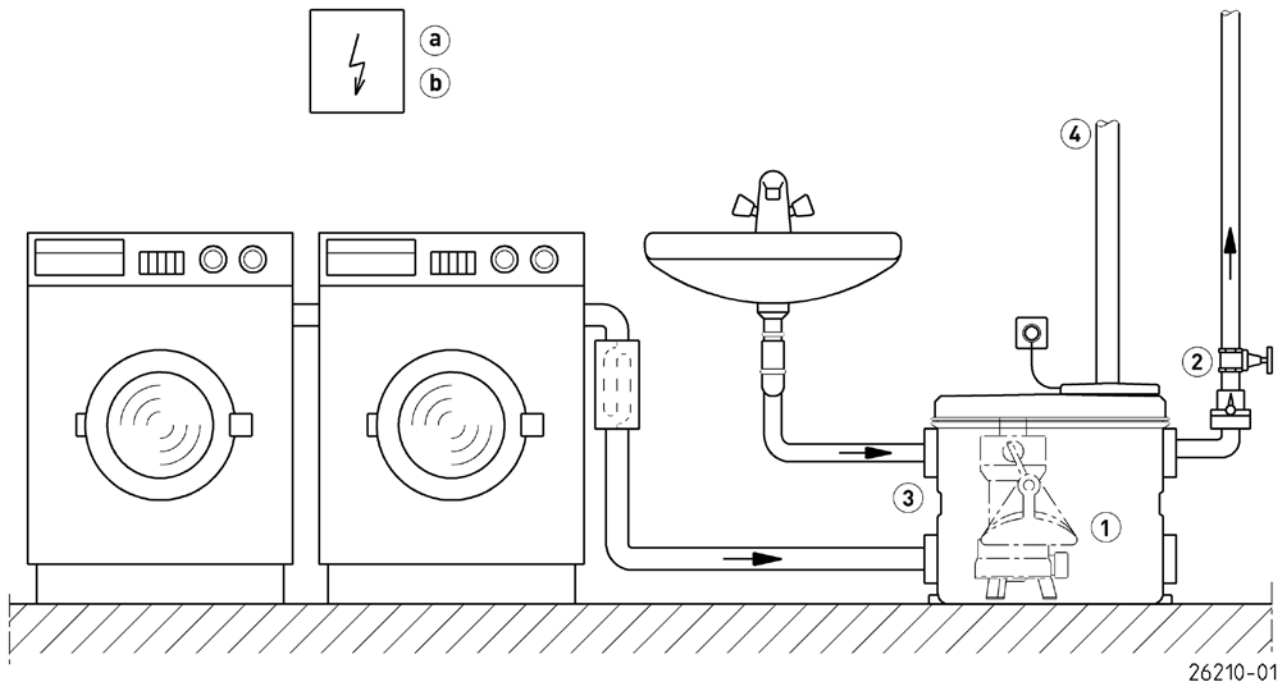





26210-01

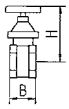

HEBEFIX 100 / 100 H

ABOVE FLOOR TANK

MECHANICAL ACCESSORY

			Code No.
	① Special float	for lower switching points	JP44795
		for lower switching points (U5 and U6)	JP44207
	② Stop valve	brass, 1/2" (DN 40), PN 16 125x60 (HxB)	JP44786
	③ Connection kid	DN 150, elastic sleeve with clamps	JP27736
	④ Special ventilation	special filter with housing, not for hot water	JP27484

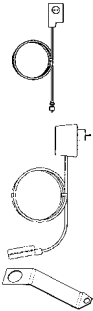
ELECTRICAL ACCESSORY

			Code No.
	a Alarm unit		
	AGR	reed switch, mains dependent, potential-free contact, 4 m cable	JP44893
	Washing machine stop		
	AWR	reed switch, mains dependent, 3 m cable	JP44897
	AWO	for alarm forwarding in case of several washing machines	JP44899
	Fastener for alarm switch	(only U3KS, U5KS and U6KS with special float switch)	JP28191
	b Rechargeable battery	9 V, for mains independent alarm	JP44850