

K2 PLUS

CONDENSATE PUMP

- For condensate \geq pH 2,7
- Float switch
- Runtime monitoring with acoustic alarm and
- potential-free alarm contact
- Visual operating/error display
- Test run button
- Integrated check valve



DESCRIPTION

The benefits offered by the new K2 plus condensate pump are a definite plus that make this pump a versatile helper. This pump works dependably to remove acidic condensate with a pH of \geq 2.7 from gas and oil, condensing boilers, air conditioning systems, air dehumidifiers and cooling units.

The K2 plus satisfies the highest requirements. It is distinguished not only by its modern design but above all by its consistently quiet operation, its compact tank dimensions and its reliability. The pump is ready to connect and operates fully automatically.

A float switch monitors the level inside the tank, while the electronic unit oversees the pump's operating time. The user is therefore alerted early to potential problems. The integrated runtime monitoring with acoustic alarm can be relayed to other places using the potential-free alarm contact.

The indicator light displays whether the system is operating or whether there is a fault. The good working order of the system can be checked at any time with the test run button.

A sand trap keeps solids out of the hydraulic system. The two-part design of the motor and collecting chamber and the rotary knobs at the side make for easy cleaning without tools.

The K2 plus is resistant to acid condensate with a pH-value of \geq 2.7. The maximum inlet temperature of the pumped media is 104 °F (40 °C).

In the case of larger volumes of condensate or additional waste water, we recommend using the Hebefix extra.

PERFORMANCE

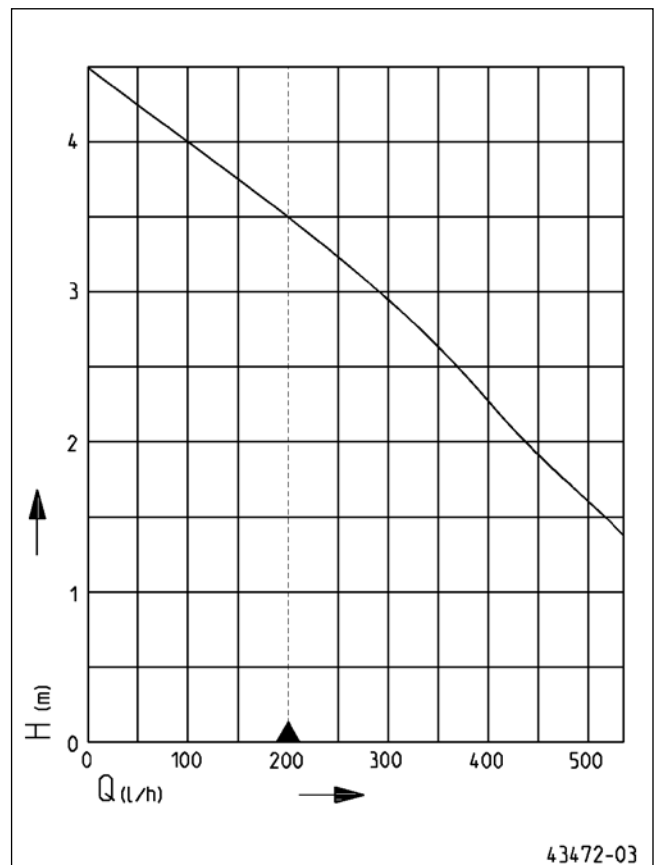

Type	Delivery head H [m]	1.5	2	2.5	3	3.5
K2 Plus	Flow rate Q [l/h]	520	440	365	290	200

Specifications can be changed without notice. Performance subject to ISO 9906 tolerances. The minimum flow velocity in the pressure piping must be 0.7 m/s according to EN 12056. This data is represented in the performance curve as a limit of application.



K2 PLUS

CONDENSATE PUMP

SCOPE OF SUPPLY

Ready to connect with 2 m power cable and safety plug, 6 m 90 mm
 PVC-pressure tube (ID 10 mm) with connector DN 50, inlet height

MECHANICAL DATA

Shaft	Stainless steel	Usable capacity	0.9 l
Impeller	Vortex impeller, plastic	Weight	3.1 kg

ELECTRICAL DATA

Voltage	1/N/PE~230 V	Wires	3G0,75
Motor rating P1	65 W	Type of enclosure	IP 24
Current	0.58 A	Motor protection	Thermostat
Power line	2m H05VV-F	Plug	Safety

K2 PLUS

Type	Code No.
K2 Plus	JP46589

Dimensions K2 plus (mm)

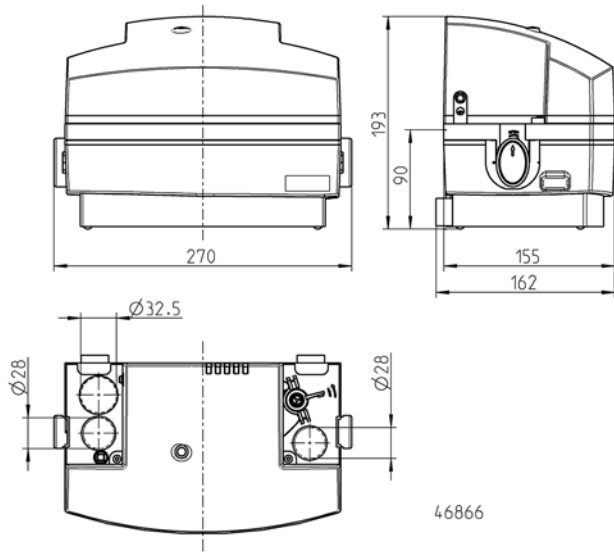

Example of installation

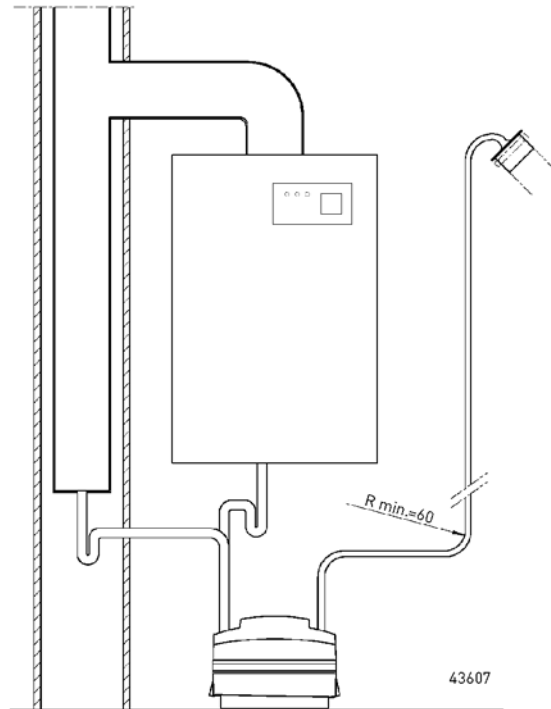

K2 PLUS

CONDENSATE PUMP

Condensates taken from condensing boiler technology are very aggressive. You will find corresponding information in the ATV working paper „Condensates from condensing boilers“, ATV-DVWL-A 251 (2011). The K2 plus is designed for use at room temperatures, a pH value of ≥ 2.7 and a maximum inlet temperature of 104 °F (40 °C). Should the condensate values fall below the above-mentioned pH value even for a short time, a neutralisation has to be installed between therm and pump. The local requirements (local discharge

regulation) as well as the neutralisation obligations of the ATV working paper are to be considered as well. Guiding values for untreated condensate can be found in the mentioned ATV working paper, table B.1. For condensate lines only approved materials in accordance with ATV working paper table 4 are to be used. If not already integrated in the unit all inlets must be provided with a siphon trap (emission trap). It is generally not permitted to install the unit outdoors.

MECHANICAL ACCESSORY

			Code No.
	Hose extension	6 m, with hose connector	JP27993

ELECTRICAL ACCESSORY

			Code No.
	Smart Home	FTJP radio transmitter	JP47209