



**PUMP TECHNICAL
SERVICES LIMITED**



THE SUBMERSIBLE PUMP SPECIALISTS

MANUFACTURING | SALES | PROJECT DESIGN | INSTALLATION | MAINTENANCE AND REPAIRS

MULTICUT

35/2 M TAN, EX

36/2 M TAN, EX

45/2 M TAN, EX

EN Instruction Manual



 service@pts-jung.co.uk

 sales@pts-jung.co.uk

Pump House
Unit 12
Bilton Road Industrial Estate
Erith, Kent, DA8 2AN

 01322 357 080

 pts-jung.co.uk

You have purchased a product made by Pentair Jung Pumpen and with it, therefore, also excellent quality and service. Secure this service by carrying out the installation works in accordance with the instructions, so that our product can perform its task to your complete satisfaction. Please remember that damage caused by incorrect installation or handling will adversely affect the guarantee.

This appliance can be used by children aged 8 years or over and by persons with limited physical, sensory or intellectual capabilities, or with limited experience and knowledge, provided that they are supervised or have been instructed in the safe use of the appliance and are aware of the dangers involved. Children must not be allowed to play with the appliance. Cleaning and user maintenance must not be carried out by children unless they are supervised.

Damage prevention in case of failure

Like any other electrical device, this product may fail due to a lack of mains voltage or a technical defect.

If damage (including consequential damage) can occur as a result of product failure, the following precautions can be taken at your discretion:

- Installation of a water level dependent (under circumstances, mains-independent) alarm system, so that the alarm can be heard before damage occurs.
- Inspection of the collecting tank/chamber for tightness up to the top edge before – or at the latest, during – installation or operation of the product.
- Installation of backflow protection for drainage units that can be damaged by wastewater leakage upon product failure.
- Installation of a further product that can compensate in case of failure of the other product (e.g. duplex unit).
- Installation of an emergency power generator.

As these precautions serve to prevent or minimise consequential damage upon product failure, they are to be strictly observed as the manufacturer's guideline – in line with the standard DIN EN specifications as state of the art – when using the product (Higher Regional Court Frankfurt/Main, Ref.: 2 U 205/11, 06/15/2012).

SAFETY INSTRUCTIONS

This instruction manual contains essential information that must be observed during installation, operation and servicing. It is therefore important that the installer and the responsible technician/operator read this instruction manual before the equipment is installed and put into operation. The manual must always be available at the location where the pump or the plant is installed.

Failure to observe the safety instructions can lead to the loss of all indemnity.

In this instruction manual, safety information is distinctly labelled with particular symbols. Disregarding this information can be dangerous.



General danger to people



Warning of electrical voltage

NOTICE! Danger to equipment and operation

Qualification and training of personnel

All personnel involved with the operation, servicing, inspection and installation of the equipment must be suitably qualified for this work and must have studied the instruction manual in depth to ensure that they are sufficiently conversant with its contents. The supervision, competence and areas of responsibility of the personnel must be precisely regulated by the operator. If the personnel do not have the necessary skills, they must be instructed and trained accordingly.

Safety-conscious working

The safety instructions in this instruction manual, the existing national regulations regarding accident prevention, and any internal working, operating and safety regulations must be adhered to.

Safety instructions for the operator/user

All legal regulations, local directives and safety regulations must be adhered to.

The possibility of danger due to electrical energy must be prevented.

Leakages of dangerous (e.g. explosive, toxic, hot) substances must be discharged such that no danger to people or the environment occurs. Legal regulations must be observed.

Safety instructions for installation, inspection and maintenance works

As a basic principle, works may only be carried out to the equipment when it is shut down. Pumps or plant that convey harmful substances must be decontaminated.

All safety and protection components must be re-fitted and/or made operational immediately after the works have been completed. Their effectiveness must be checked before restarting, taking into account the current regulations and stipulations.

Unauthorised modifications, manufacture of spare parts

The equipment may only be modified or altered in agreement with the manufacturer. The use of original spare parts and accessories approved by the manufacturer is important for safety reasons. The use of other parts can result in liability for consequential damage being rescinded.

Unauthorised operating methods

The operational safety of the supplied equipment is only guaranteed if the equipment is used for its intended purpose. The limiting values given in the "Technical Data" section may not be exceeded under any circumstances.

Instructions regarding accident prevention

Before commencing servicing or maintenance works, cordon off the working area and check that the lifting gear is in perfect condition.

Never work alone. Always wear a hard hat, safety glasses and safety shoes and, if necessary, a suitable safety belt.

Before carrying out welding works or using electrical devices, check to ensure there is no danger of explosion.

People working in wastewater systems must be vaccinated against the pathogens that may be found there. For the sake of your health, be sure to pay meticulous attention to cleanliness wherever you are working.

Make sure that there are no toxic gases in the working area.

Observe the health and safety at work regulations and make sure that a first-aid kit is to hand.

In some cases, the pump and the pumping medium may be hot and could cause burns.

For installations in areas subject to explosion hazards, special regulations apply!

AREAS OF APPLICATION

Submersible pumps in the MultiCut range are suitable for the drainage of single dwellings.

MultiCut pumps are principally used for:

- effluent containing fibrous matter
- effluent containing solids (without stones)
- domestic effluent without faecal matter
- domestic effluent with faecal matter
- mechanically cleaned effluent

The submersible pumps MultiCut ... TAN, EX are supplied with explosion protection.

When using the pumps, the relevant national laws, regulations and stipulations must be adhered to, for example:

- Installation of lowvoltage systems (e.g., VDE 0100 in Germany)
- Safety and working materials (e.g., BetrSichV and BGR 500 in Germany)
- Safety in wastewater systems (e.g., GUV-VC5, GUV-R104, GUV-R126 in Germany)
- Electrical systems and operating resources (e.g., GUV-VA3 in Germany)
- Explosion protection EN 60079-0, EN 60079-1 and EN 1127-1.

For non-standard utilisation conditions in areas subject to explosion hazards, please ask the local authority responsible.

In Germany, this would be, for example, the Trade Supervisory Centre (Gewerbeaufsicht), the Technical Inspection Agency (TÜV), the building authority (Bauamt) or professional organisation (Berufsgenossenschaft).

The installation and operation of this equipment is regulated by the ordinance concerning the protection of health and safety in the provision of work equipment and its use at work, concerning safety when operating installations subject to monitoring, and concerning the organisation of industrial health and safety at work, (Betriebssicherheitsverordnung), Article 1.

Modes of operation

with the pumped medium at a temperature of 40°C:

Motor submersed: continuous operation S1

Motor emerged: short duration operation S2; see "Technical Data"

Motor emerged: intermittent operation S3; see "Technical Data"

The submersible pump is frost-resistant down to -20°C when stored in dry conditions. When installed, however, it must not be allowed to freeze in the water.

Transport

The pump must never be lifted by the power supply cable! The pump should only be lowered by using a chain.

ELECTRICAL CONNECTION

By using our controls, you can be sure that the requirements of the EU type-testing certificate are met.

NOTICE! Only qualified electricians may carry out electrical works to the pump or the controls.

The standards applicable in each case (e.g. EN), the country-specific regulations (e.g. VDE in Germany), and the regulations of the local supply network operator must be observed.

NOTICE! Never lay the end of cables in water! Penetrating water may cause malfunctions.

Alterations to the circuitry are to be made using crimp connectors (X) between the conil plug connection (Y) and the built-in motor. The new crimp connection must be professionally made.

Only slow-blow fuses or automatic fuses with C or D characteristics are to be used as pre-fuses for the pump. Necessary fuse protection for direct on-line start: 16 A.

Δ-Circuitry for low voltage

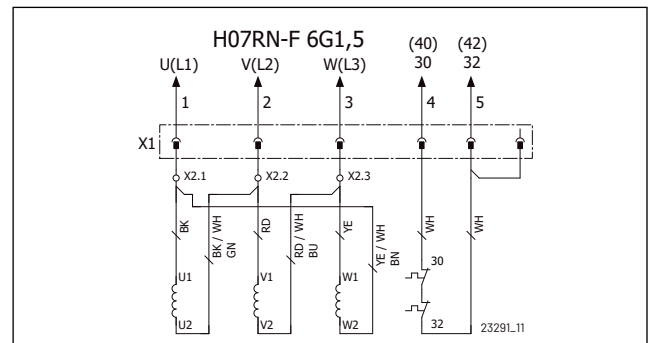

Y-Circuitry for high voltage

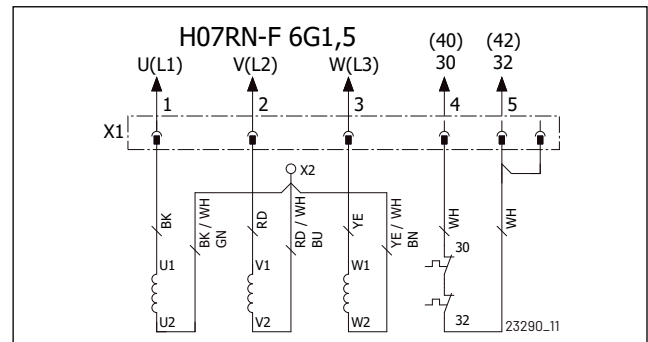

The pump must be protected via an overload trip. Setting for direct on-line start = nominal current.

If the protective device has been triggered, the cause of the malfunction must be eliminated before switching on again.

Coil thermostats

NOTICE! In addition to the overload trip or protective switch of the motor, the thermostats integrated in the motor winding must also be connected. The thermostats are suitable for 250 V / 1.2 A (cos phi = 0.6) and are labelled 30 and 32 for connection purposes.

For this reason, after the protective device has been triggered, the mains cable must be unplugged before remedying the cause of the failure, as otherwise the pump will be automatically switched on again.

Thermostat connection with explosion protection

The thermostats are to be connected in such a way that the motor is switched off via the control circuit when the response temperature is reached. It must not be possible for the motor to switch on again automatically after the winding has cooled down.

WARNING!

After an automatic cut-out via the temperature limiters, the cause of the malfunction must first be eliminated. Only then may the motor be switched on again manually.

The restart interlock must be "non-resetting on power failure", i.e. the lock must be in place to prevent restarting even after a power cut (in Europe: Directive 2014/34/EU, Appendix II 1.5, EN 60079-17 Table1, B10).

Operation with frequency converter

Frequency converters may only be used for controlling the frequency of special models of three-phase pumps. For hydraulic reasons we do not recommend operation below 30 Hz.

NOTICE! For physical reasons, pumps may not be operated at a higher frequency than that shown on the type plate. If the frequency increases beyond the value on the type plate, the power input increases and the motor is then overloaded.

For special models of three-phase pumps that are designed for frequency converter operation, the motor type shown on the type plate is labelled with an additional "K" (e.g. D90-2/75 CK). These pumps also have a sticker on the end of the cable that indicates their suitability for use with a frequency converter.

These special motors are fitted with PTC thermistors as winding protectors. Voltages of more than 2.5 V may not be connected to the winding protection terminals 40 and 41! For explosion protected pumps, a type-tested tripping unit that complies with the EU type-testing requirements is also necessary.

Rotational direction

Not applicable for alternating current pumps. The rotational direction must be checked before installation! If the rotational direction is correct, the start-up jolt should be in the opposite direction to the rotational direction arrow on the motor housing. The wrong rotational direction is also indicated if the pump performs inadequately when installed, or if loud noises can be heard during operation. If the rotational direction is wrong, 2 phases of the supply cable must be swapped over.

CAUTION!

The start-up jolt can be very forceful.

Potential equalisation

To comply with EN 60079-14 and EN 1127-1, an additional equipotential bonding must be installed for facilities with protective earth conductors in TN/TT networks in areas subject to explosion hazards. In Germany, for example, the design must be in accordance with VDE 0100, Part 540 (Association of German Electrical Engineers).

No additional potential equalisation is required on site for JUNG PUMPEN concrete or plastic chambers in explosion zones 1 and 2 (statement made by TÜV Nord (Technical Inspection Agency) in March 2008).

Exception: if conductive parts, such as cable protection sleeves made of corrugated pipe or a pressure pipe made of metal, are connected to the chamber from the outside. In this case, an electrically conductive connection must be made between the conductive parts and the housing of the pump(s). For corrosion protection reasons, the connection should be made using stainless steel.

Explosion protected pumps have a special connection point at the cable entry point.

INSTALLATION

The pump must be installed as shown in the examples. For installations in accordance with EN 12056-4, the pressure pipe must be laid in a loop above the local back pressure level and protected with a back pressure valve.

Example installation

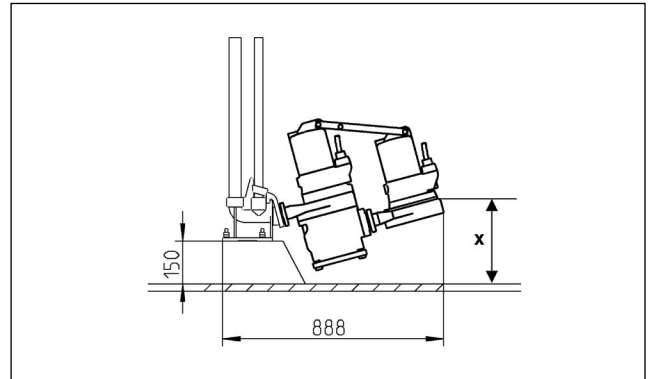

Assembly: Fix the coupling base firmly to the floor of the collection chamber using plugs and then mount the guide rails. Next, install the pressure pipe including the necessary fittings, such as the non-return valve and shut-off valves.

Finally, fit the pumps with the screwed-on coupling catch on to the guide rails and lower it into place using a chain fixed to the shackle.

A fixing facility for lifting gear should be provided above the chamber opening at a sufficient height.

Level monitoring can be carried out using various systems. Their specific characteristics and requirements can be found in the relevant operating manuals.

WARNING!

In accordance with the explosion protection laws and regulations, JUNG Ex-pumps should never be allowed to run dry or to operate in "snore" mode.

The pump must switch off when the water level sinks to the upper edge of the pump housing (x in the illustration), at the very latest. This shut-down must be implemented via a separate switching circuit. Dry running for servicing or inspection purposes may only take place outside the potentially explosive area.

A correspondingly larger diameter pipe should be used for longer pressure pipelines to avoid pipe friction losses.

Rising pressure pipes must be protected from frost! A chamber cover must be selected that is suitable for the intended use and has the required load-bearing capacity.

If the pump is malfunctioning, part of the contents of the oil reservoir could escape into the pumping medium.

SERVICING

Maintenance and inspection of this product must be carried out in accordance with EN 12056-4 and EN 60074-19.

To ensure continued reliability of service, we recommend that you take out a service contract.



WARNING!

Before carrying out any works: disconnect the pump and the controls from the mains and take steps to ensure that it cannot be energized again.



WARNING!

Check the mains cable for signs of mechanical and chemical damage. Damaged or kinked cables must be replaced by the manufacturer.

NOTICE! When using a chain to lift the pump, please observe the relevant national regulations regarding accident prevention. Lifting gear must be checked regularly by an expert in accordance with the legal regulations.

NOTICE! Motors in the Ex-range conform to the "flameproof enclosures" ignition protection category. Maintenance works that affect the explosion protection may only be carried out by authorised specialists or by the manufacturer. When carrying out repairs, all areas next to flameproof gaps must be checked for damages and, if necessary, replaced by genuine parts.

Oil check

The oil reservoir is sealed on the outside with a sealing screw "Ö" (oil). In order to check the mechanical seal, the oil, including any residue, must be drained from the oil reservoir and collected in a clean measuring container.

- If the oil is contaminated with water (milky), an oil change must be carried out. Check again after a further 300 operating hours, but at the very latest after 6 months!
- However, if the oil is contaminated with both water and pollutants, then not only the oil must be replaced, but the mechanical seal as well.

For monitoring the oil reservoir, it is also possible to retrofit the electrode of our "DKG" or DKG-Ex" seal leak control device in place of the "DKG" sealing screw.

Changing the oil

To ensure operational liability, the first oil change should be carried out after 300 operating hours, with further oil changes carried out after every 1000 operating hours.

If the number of operating hours is very low, an oil change should still be carried out at least once a year.

If wastewater with strongly abrasive constituents is being pumped, the oil changes should be carried out at correspondingly shorter intervals.

Use HLP hydraulic mineral oil, viscosity class 22 to 46, e.g. Mobil DTE 22, DTE 24, DTE 25, to replace the oil in the oil reservoir.

The volume of oil required is 520 cm³ for MultiCut 25/2 to 36/2 and 750 cm³ for MultiCut 45/2.-

NOTICE! The oil reservoir may only be filled with the specified quantity of oil. Overfilling will result in the pump being rendered inoperable.

Checking the pump unit

The housing screws for the pump, and the connecting and fixing screws of the installation must be checked to ensure they are fixed securely. They should be tightened if necessary.

If the pump performance decreases, or if increasingly loud noises can be heard during operation, or if the cutting performance decreases (the pump tends to become blocked), the impeller and cutting system must be checked for wear by an expert and replaced if necessary.

Replace the impeller



CAUTION!

Worn impellers can have sharp edges.

1. Block the cutting rotor with a piece of wood and unscrew the central hexagon socket screw



2. Remove the compression piece and screw the extraction tool (code no. JP50325) into the thread of the cutting rotor. Tightening the inner screw pulls the cutting rotor off the pump shaft.



3. Unscrew the four hexagon socket screws on the top of the spiral housing, and take off the spiral housing.
4. Fit the new impeller with the feather key onto the shaft, using the same number of adjusting washers as before.

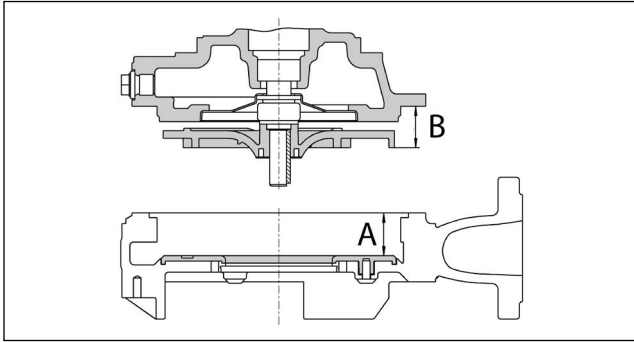

5. Measure dimension B on each blade and note the largest measurement.
6. Measure dimension A in several places and note the smallest measurement.
7. **Notice!** The impeller gap A-B must measure 0,5–0,7 mm. If the gap is larger or smaller, use adjusting washers (12x16x0.2) under the impeller to adjust the gap.
8. Screw the spiral housing and the oil reservoir/motor back together again.
9. As a final step, put the cutting rotor back on and adjust the cutting gap.

Checking the cutting clearance

Using a suitable tool, e.g. feeler gauge, the cutting clearance between the cutting rotor and the cutting plate can be measured. A cutting clearance of over 0.2 mm must be reduced.

Adjustment of the cutting clearance

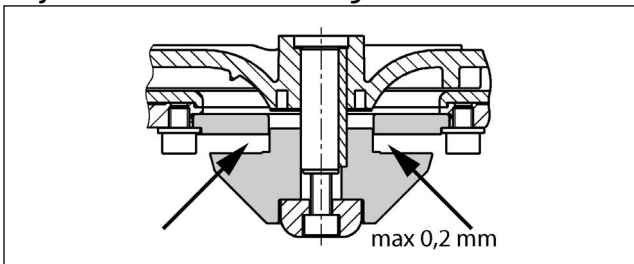

1. Block the cutting rotor with a piece of wood and unscrew the central hexagon socket screw.
2. Remove the compression piece and screw the extraction tool (code no. JP50325) into the thread of the cutting rotor. Tightening the inner screw pulls the cutting rotor off the pump shaft.
3. Remove the cutting rotor and one adjusting washer; remove the extraction tool and then reinstall the compression piece and cutting rotor.
4. Block the cutting rotor and tighten again with the hexagon socket screw (tightening torque 8 Nm).
5. Check the freedom of movement of the cutting rotor and the cutting clearance again (max. 0.2 mm).

If the cutting clearance is still too big, a further adjusting washer must be removed. Steps 1-4 must be repeated.

Cleaning



CAUTION!

Worn impellers can have sharp edges.

To clean the impeller and the spiral housing first of all remove the compression piece and the cutting rotor as described above. Then unscrew the 4 hexagon socket screws and remove

the spiral housing.

The impeller and the spiral housing can now be cleaned. After this fit the individual components again and adjust the cutting clearance.

To clean the pump chamber a flushing pipe can be fitted as and when required. To do so, the "Luft" (air) sealing screw is removed and in its place the flushing pipe fitted to the pump.

NOTICE! If the wrong screws are unscrewed, the oil will run out of the oil reservoir.

Tightening torque M_A for A2 screw materials

- for M 6 $M_A = 8 \text{ Nm}$
- for M 8 $M_A = 20 \text{ Nm}$
- for M 10 $M_A = 40 \text{ Nm}$
- for M 12 $M_A = 70 \text{ Nm}$
- for M 16 $M_A = 160 \text{ Nm}$

WHAT TO DO IN THE EVENT OF ANY PROBLEMS

Pump does not work

- Check mains current (do not use a pin gauge)
- Fuse faulty = may be too weak (please refer to Electrical Connection)
- Mains supply cable damaged = repair to be carried out by manufacturer only

Pump runs but does not pump

- Empty pressure pipe or hose to allow the non-return valve to open and let the air escape from the spiral housing.
- Ventilate the pump housing by unscrewing the "Luft" (air) sealing screw.

Cutting system blocked

- Check the cutting system and readjust or replace as necessary.

Impeller blocked

- Clean spiral housing and impeller.

Decreased pumping performance

- The impeller is worn out = replace it
- Wrong direction of rotation = change 2 phases of the power supply

 0197
JUNG PUMPEN GmbH - Industriestr. 4-6 33803 Steinhagen, Germany 13 411.16.2022.01
EN 12050-1:2001; 2015 Fäkalienhebeanlage
35/2 M Tan, EX (JP50362) 36/2 M Tan, EX (JP50368) 45/2 M Tan, EX (JP50374)
Sammeln und automatisches Heben von fäkalienfreiem und fäkalienhaltigem Abwasser über die Rückstauenebene

 0197
JUNG PUMPEN GmbH - Industriestr. 4-6 33803 Steinhagen, Germany 13 411.16.2022.01
EN 12050-1:2001; 2015 Lifting plant for wastewater containing faecal matter
35/2 M Tan, EX (JP50362) 45/2 M Tan, EX (JP50374) 36/2 M Tan, EX (JP50368)
Collection and automatic lifting of wastewater without sewage and wastewater containing faecal matters above the backflow level

BRANDVERHALTEN	NPD
WASSERDICHTHEIT	Bestanden
WIRKSAMKEIT (HEBEWIRKUNG)	
- Förderung von Feststoffen	Bestanden
- Rohranschlüsse	Bestanden
- Mindestmaße von Lüftungsleitungen	NPD
- Mindestfließgeschwindigkeit	Bestanden
- Freier Mindestdurchgang der Anlage	Bestanden
- Mindestnutzvolumen	NPD
MECHANISCHE FESTIGKEIT	
- Tragfähigkeit und strukturelle Stabilität des Sammelbehälters für die Verwendung außerhalb von Gebäuden	NPD
- Strukturelle Stabilität des Sammelbehälters für die Verwendung innerhalb von Gebäuden	NPD
GERÄUSCHPEGEL	70 dB(A)
DAUERHAFTIGKEIT	
- der Wasserdichtheit und Luftdichtheit	Bestanden
- der Hebewirkung	Bestanden
- der mechanischen Festigkeit	Bestanden
GEFÄHRLICHE SUBSTANZEN	NPD

REACTION TO FIRE	NPD
WATERTIGHTNESS	Pass
EFFECTIVENESS (LIFTING EFFECTIVENESS)	
- Pumping of solids	Pass
- Pipe connections	Pass
- Minimum dimensions of ventilating pipes system	NPD
- Minimum flow velocity	Pass
- Minimum free passage of the plant	Pass
- Minimum useful volume	NPD
MECHANICAL RESISTANCE	
- Load bearing capacity and structural stability of collection tank for use outside buildings	NPD
- Structural stability of collection tank for use inside buildings	NPD
NOISE LEVEL	70 dB(A)
DURABILITY	
- of structural stability	Pass
- of lifting effectiveness	Pass
- of mechanical resistance	Pass
DANGEROUS SUBSTANCES	NPD

EU-Konformitätserklärung
EU-Prohlášení o shodě
EU-Overensstemmelseserklæring
EU-Declaration of Conformity
EU-Vaatumustenmukaisuusvakuutus

EU-Déclaration de Conformité
EU-Megfelelőségi nyilatkozat
EU-Dichiarazione di conformità
EU-Conformiteitsverklaring
EU-Deklaracja zgodności

EU-Declaração de Conformidade
EU-Declarație de conformitate
EU-Vyhlášení o zhode
EU-Försäkran om överensstämmelse

DE - Richtlinien - Harmonisierte Normen
CS - Směrnice - Harmonizované normy
DA - Direktiv - Harmoniseret standard
EN - Directives - Harmonised standards
FI - Direktiivi - Yhdenmukaistettu standardi

FR - Directives - Normes harmonisées
HU - Irányelve - Harmonizált szabványok
IT - Direttive - Norme armonizzate
NL - Richtlijnen - Geharmoniseerde normen
PL - Dyrektywy - Normy zharmonizowane

PT - Directiva - Normas harmonizadas
RO - Directivă - Norme coroborate
SK - Smernice - Harmonizované normy
SV - Direktiv - Harmoniserade normer

• 2006/42/EG (MD) EN 809:1998/AC:2010, EN ISO 12100:2010
• 2011/65/EU (RoHS)
• 2014/30/EU (EMC) EN 60034-1: 2010/AC: 2010, EN 61000-3-2:2014, EN 61000-3-3:2013
• 2014/34/EU (ATEX) EN 60079-0:2018, EN 60079-1:2014

JUNG PUMPEN GmbH - Industriestr. 4-6 - 33803 Steinhagen - Germany - www.jung-pumpen.de

DE - Wir erklären in alleiniger Verantwortung, dass das Produkt den aufgeführten Richtlinien entspricht.

CS - Prohlašujeme na svou výlučnou odpovědnost, že výrobek odpovídá jmenovaným směrnicím.

DA - Vi erklærer under ansvar at produktet i overensstemmelse med de retningslinjer

EN - We hereby declare, under our sole responsibility, that the product is in accordance with the specified Directives.

FI - Me vakuutamme omalla vastuullamme, että tuote täyttää ohjeita.

FR - Nous déclarons sous notre propre responsabilité que le produit répond aux directives.

HU - Kizárólagos felelősségünk tudatában kijelentjük, hogy ez a termék megfelel az Európai Unió fentvezett irányelveinek.

IT - Noi dichiariamo sotto la nostra esclusiva responsabilità che il prodotto è conforme alle direttive citate

NL - Wij verklaren geheel onder eigen verantwoordelijkheid dat het product voldoet aan de gestelde richtlijnen.

PL - Z pełną odpowiedzialnością oświadczamy, że produkt odpowiada postanowieniom wymienionych dyrektyw.

PT - Declaramos, sob nossa exclusiva responsabilidade, que o produto está em conformidade com as Diretivas especificadas.

RO - Declaram pe proprie răspundere că produsul corespunde normelor prevăzute de directivele mai sus menționate.

SK - Na výlučnú zodpovednosť vyhlasujeme, že výrobok spĺňa požiadavky uvedených smerníc.

SV - Vi försäkrar att produkten på vårt ansvar är utför enligt gällande riktlinjer.

10/2 A1, EX (JP09628/4)	10/2 AW1, EX (JP47280)	25/2 AW1, EX (JP09272)	45/2 CW1, EX (JP47353)	36/2 M, EX (JP50366)
10/4 B1, EX (JP09633/4)	10/4 CW1, EX (JP09609/5)	25/2 BW1, EX (JP09499/1)	45/4 AW2, EX (JP46869)	36/2 M, EX (JP50367)
15/2 A1, EX (JP09629/4)	15/2 AW1, EX (JP47278)	25/4 AW2, EX (JP46867)	45/4 BW2, EX (JP46859)	36/2 M, EX (JP50601)
15/4 B3, EX (JP09635/4)	15/4 AW2, EX (JP46792)	25/4 BW1, EX (JP09459/1)	45/4 CW2, EX (JP47237)	45/2 M, EX (JP50371)
25/2 A2, EX (JP09630/4)	15/4 BW1, EX (JP09458/1)	25/4 CW1, EX (JP09656/5)		45/2 M, EX (JP50372)
25/2 B1, EX (JP09631/4)	15/4 CW1, EX (JP09611/5)	35/2 AW1, EX (JP09152/4)	25/2 ME, EX (JP50355)	45/2 M, EX (JP50373)
25/4 B4, EX (JP09636/4)	25/2 AW1, EX (JP09150/4)	35/2 BW1, EX (JP09501/1)	25/2 ME, EX (JP50599)	45/2 M, EX (JP50602)
25/4 C1, EX (JP09637/4)	25/2 AW1, EX (JP46123)	35/4 AW2, EX (JP46868)	35/2 M, EX (JP50359)	35/2 M Tan, EX (JP50362)
35/2 A2, EX (JP09653/4)	25/2 AW1, EX (JP46124)	35/4 BW1, EX (JP09460/1)	35/2 M, EX (JP50360)	36/2 M Tan, EX (JP50368)
35/2 B2, EX (JP09654/4)	25/2 AW1, EX (JP46119)	35/4 CW1, EX (JP09859/5)	35/2 M, EX (JP50361)	45/2 M Tan, EX (JP50374)
35/4 B4, EX (JP09649/4)	25/2 AW1, EX (JP47213)	45/2 AW1, EX (JP46870)	35/2 M, EX (JP50600)	
35/4 C1, EX (JP09650/4)	25/2 AW1, EX (JP46120)	45/2 BW1, EX (JP46857)	36/2 M, EX (JP50365)	

DE-Weitere normative Dokumente CS-Jinými normativními dokumenty DA-Andre normative dokumenter EN-Other normative documents FI-Muiden normien FR-Autres documents normatifs HU-Egyéb szabályozó dokumentumokban leírtaknak IT-Altri documenti normativi NL-Verdere normatieve documenten PL-Innymi dokumentami normatywnymi PT-Outros documentos normativos RO-Alte acte normative SK-Iným závazným dokumentom SV-Vidare normerande dokument:

EN 60034-5:2001/A1:2007

EN 60079-14:2014

DE-Bevollmächtigter für technische Dokumentation CS-Oprávněná osoba pro technickou dokumentaci DA-utoriseret person for teknisk dokumentation EN-Authorized person for technical documentation FI-Valtuutettu henkilö tekninen dokumentaatio FR-Personne autorisée à la documentation technique HU-Hivatalos személy műszaki dokumentáció IT-Persona abilitata per la documentazione tecnica NL-Bevoegd persoon voor technische documentatie PL-Pełnomocnik ds. dokumentacji technicznej PT-Pessoa autorizada para documentação técnica RO-Persoană autorizată pentru documentație tehnică SK-Oprávněná osoba pre technickú dokumentáciu SV-Auktoriserad person for teknisk dokumentation:

JUNG PUMPEN - Stefan Sirges - Industriestr. 4-6 - 33803 Steinhagen

Steinhagen, 05-01-2022

 II 2 G Ex db IIB T4 Gb PBT 08 ATEX 1113 X 01

Physikalisch-Technische Bundesanstalt
Zertifizierungssektor Explosionsschutz (0102)
Bundesallee 100 - 38116 Braunschweig - Germany

Stefan Sirges, General Manager

i.V. 
Pascal Kölbebeck, Sales Manager



EU-Baumusterprüfbescheinigung

PTB 08 ATEX 1113 X

Ausgabe: 01

- (1) Geräte oder Schutzsysteme zur bestimmungsgemäßen Verwendung in explosionsgefährdeten Bereichen - **Richtlinie 2014/34/EU**
- (2) EU-Baumusterprüfbescheinigungsnummer
- (3) Produkt: Tauchpumpenmotoren Typ. 90 - ...
- (4) Hersteller: Jung Pumpen GmbH
- (5) Anschrift: Industriestraße 4 - 6, 33803 Steinhausen, Deutschland
- (6) Die Bauart dieses Produkts sowie die verschiedenen zulässigen Ausführungen sind in der Anlage und den darin aufgeführten Unterlagen zu dieser Baumusterprüfbescheinigung festgelegt.
- (7) Die Physikalisch-Technische Bundesanstalt, notifizierte Stelle Nr. 0102 gemäß Artikel 17 der Richtlinie 2014/34/EU des Europäischen Parlaments und des Rates vom 26. Februar 2014, bescheinigt, dass dieses Produkt die grundlegenden Sicherheits- und Gesundheitsanforderungen für die Konzeption und den Bau von Produkten zur bestimmungsgemäßen Verwendung in explosionsgefährdeten Bereichen gemäß Anhang II der Richtlinie erfüllt.
- (8) Die Ergebnisse der Prüfung sind in dem vertraulichen Prüfbericht PTB Ex 15-15108 festgehalten.
- (9) Die grundlegenden Sicherheits- und Gesundheitsanforderungen werden erfüllt durch Übereinstimmung mit **EN 60079-0:2012+AMD11:2013 EN 60079-1:2014**
- (10) Falls das Zeichen „X“ hinter der Bescheinigungsnummer steht, wird auf besondere Bedingungen für die sichere Anwendung des Produkts in der Anlage zu dieser Bescheinigung hingewiesen.
- (11) Diese EU-Baumusterprüfbescheinigung bezieht sich nur auf Konzeption und Prüfung des festgelegten Produkts gemäß Richtlinie 2014/34/EU. Weitere Anforderungen dieser Richtlinie gelten für die Herstellung und das Bereitstellen auf dem Markt. Diese Anforderungen werden nicht durch diese Bescheinigung abgedeckt.
- (12) Die Kennzeichnung des Produkts muss die folgenden Angaben enthalten:

 **II 2 G Ex db IIB T4 Gb**

Konformitätsbewertungsstelle, Sektor Explosionsschutz Braunschweig, 21. Juni 2016

Im Auftrag

Dr.-Ing. U. Klausmayer
Direktor und Professor



EU-Baumusterprüfbescheinigung ohne Unterschrift und ohne Siegel haben keine Gültigkeit.
Diese EU-Baumusterprüfbescheinigung darf nur unverändert weiterverbreitet werden.
Auszüge oder Änderungen bedürfen der Genehmigung der Physikalisch-Technischen Bundesanstalt.
Physikalisch-Technische Bundesanstalt • Bundesallee 100 • 38116 Braunschweig • DEUTSCHLAND

Seite 1/5

ZSEK101000 c

(1) EU-TYPE-EXAMINATION CERTIFICATE (Translation)

- (2) Equipment or Protective Systems Intended for Use in Potentially Explosive Atmospheres - **Directive 2014/34/EU**
- (3) EU-Type Examination Certificate Number: **PTB 08 ATEX 1113 X** **Issue: 01**
- (4) Product: Submersible pump motors, type . 90 - ...
- (5) Manufacturer: Jung Pumpen GmbH
- (6) Address: Industriestraße 4 - 6, 33803 Steinhausen, Germany
- (7) This product and any acceptable variation thereto is specified in the schedule to this certificate and the documents therein referred to.
- (8) The Physikalisch-Technische Bundesanstalt, notified body No. 0102 in accordance with Article 17 of the Directive 2014/34/EU of the European Parliament and of the Council, dated 26 February 2014, certifies that this product has been found to comply with the Essential Health and Safety Requirements relating to the design and construction of products intended for use in potentially explosive atmospheres, given in Annex II to the Directive.
- (9) The examination and test results are recorded in the confidential Test Report PTB Ex 15-15108.
Compliance with the Essential Health and Safety Requirements has been assured by compliance with: **EN 60079-0:2012+AMD11:2013 EN 60079-1:2014**
- (10) If the sign "X" is placed after the certificate number, it indicates that the product is subject to the Specific Conditions of Use specified in the schedule to this certificate.
- (11) This EU-Type Examination Certificate relates only to the design and construction of the specified product in accordance to the Directive 2014/34/EU. Further requirements of the Directive apply to the manufacturing process and supply of this product. These are not covered by this certificate.
- (12) The marking of the product shall include the following:

 **II 2 G Ex db IIB T4 Gb**

Konformitätsbewertungsstelle, Sektor Explosionsschutz Braunschweig, June 21, 2016

On behalf of PTB:

Dr.-Ing. U. Klausmayer
Direktor und Professor



EU-Type Examination Certificates without signature and official stamp shall not be valid. The certificates may be circulated only without alteration. Extracts or alterations are subject to approval by the Physikalisch-technische Bundesanstalt.
In case of dispute, the German text shall prevail.

Physikalisch-Technische Bundesanstalt • Bundesallee 100 • 38116 Braunschweig • GERMANY

sheet 1/5

Anlage

- (13)
- (14) **EU-Baumusterprüfbescheinigung PTB 08 ATEX 1113 X, Ausgabe: 01**
- (15) **SCHEDULE**

Beschreibung des Produkts

Bei dem Gerät handelt es sich um eine drehende elektrische Maschine zum Antrieb von Pumpen. Der Motorteil ist in der Zündschutzart Druckfeste Kapselung "d" ausgeführt. Die Stromzufuhr erfolgt über schwere Gummischlauchleitung NSSHou oder ein mindestens gleichwertiges, geprüftes Kabel.

Beschreibung der Ergänzungen und Änderungen

Die Motortypen D 90 – 2/150 A und D 90 – 4/150 A werden im Zuge dieser Ausgabe 01 mit aufgenommen.

Bemessungsgrößen für Typ D 90 - 2/150 A und D 90 - 4/150 A

Diese Bescheinigung gilt unter der Voraussetzung, dass sich die Motoren dieses Typs hinsichtlich der elektrischen und thermischen Beanspruchung nur unwesentlich von dem geprüften Muster unterscheiden, für die folgenden Ausführungen:

Typ D 90 - 2/150 A

Leistung (Aufnahme):	6,00	kW
Spannung:	218 - 242	380 - 420 V
Strom:	16,9	9,7 A
Leistungsfaktor:	0,88...0,9	
Frequenz:	50 oder 60	Hz
Drehzahl:	2788 bzw. 3088	min ⁻¹
Fördermitteltemperatur:	max. 40	°C
Betriebsarten:	S1 für max. 9 cm ausgetauchten Motor, S2 15 min., S3 20 % ¹⁾	
¹⁾ Spieldauer	10 min.	

Die Bescheinigung gilt auch für Motoren mit einer geringeren Aufnahmeleistung, jedoch maximal bis zu einem Maximalwert von 6,00 kW.

Die entsprechenden Daten sind vom Hersteller auf dem Leistungsschild anzugeben.

Neben den oben angegebenen Spannungen sind auch dazwischenliegende Werte zulässig. Die zugehörigen Ströme sind im reziproken Verhältnis der Spannung umzurechnen.

Gegenüber den Bemessungswerten darf die Netzspannung bis zu $\pm 5\%$ und die Netzfrequenz bis zu $\pm 2\%$ entsprechend dem Bereich A nach IEC 60034-1 schwanken.

Seite 2/5

EU-Baumusterprüfbescheinigungen ohne Unterschrift und ohne Siegel haben keine Gültigkeit.
 Diese EU-Baumusterprüfbescheinigung darf nur unverändert weiterverbreitet werden.
 Auszüge oder Änderungen bedürfen der Genehmigung der Physikalisch-Technischen Bundesanstalt.
 Physikalisch-Technische Bundesanstalt • Bundesallee 100 • 38116 Braunschweig • DEUTSCHLAND

Description of Product

The equipment is a rotary electric machine used for driving pumps. The motor section is designed to Flameproof Enclosure "d" type of protection. For power supply, heavy-duty NSSHou rubber hose lines are used or tested cables of equivalent or better quality.

Description of the supplements and changes

The motor types D 90 – 2/150 A and D 90 – 4/150 A shall be included as part of this issue 01.

Ratings for type D 90 – 2/150 A and D 90 – 4/150 A

This certificate is valid for the following designs providing the motors of this type differ only negligibly from the sample tested as regards the electrical and thermal stresses:

Power: (input)	6,00	kW
Voltage:	218 - 242	380 - 420 V
Current:	16,9	9,7 A
Power factor:	0,88...0,9	
Frequency:	50 or 60	Hz
Speed: (motor)	2788 resp. 3088	min ⁻¹
Temperature of flow medium: max.	40	°C
Duty Type:	S 1 for max. 9 cm not submerged motor, S2 15 min., S3 20 % ¹⁾	
¹⁾ cycle time	10 min.	

This certificate also applies for motors with a lower input power, to a maximum value of 6,00 kW.

The manufacturer has to indicate the corresponding data on the rating plate.

In addition to the above-mentioned voltages, intermediate values are also permissible. The associated currents are to be converted in the inverse ratio to the voltages.

The mains voltage may vary by up to $\pm 5\%$ and the mains frequency by up to $\pm 2\%$ from the rated values, in keeping with range A according to IEC 60034-1.

sheet 2/5

EU-Type Examination Certificates without signature and official stamp shall not be valid. The certificates may be circulated only without alteration. Extracts or alterations are subject to approval by the Physikalisch-technische Bundesanstalt.
 In case of dispute, the German text shall prevail.

Physikalisch-Technische Bundesanstalt • Bundesallee 100 • 38116 Braunschweig • GERMANY



Physikalisch-Technische Bundesanstalt
Braunschweig und Berlin
Nationales Metrologieinstitut



Anlage zur EU-Baumusterprüfbescheinigung PTB 08 ATEX 1113 X, Ausgabe: 01

Die Bescheinigung gilt auch für Motoren, die mit 60 Hz betrieben werden. Hierbei darf die max. Leistung (Aufnahme) von $P_1 = 6,00$ kW nicht überschritten werden.

Temperaturüberwachung

Bei Motoren mit Kaltleiterschutz muss sichergestellt sein, dass bei festgebremstem Läufer und einem Verhältnis $I_n/I_N = 4,4$ die Auslösezeit $t_A = 27,7$ s mit einer Toleranz von ± 20 % eingehalten wird. Dabei ist vom kalten Motor (20°C) und einer Netzspannung 400 V bei 50 Hz auszugehen.

Zur Vermeidung unzulässig hoher Temperaturen am Motorteil sind folgende Bedingungen zu beachten:
In der Betriebsart S1 muss der Motor in das Fördermedium eingetaucht (max. Austauschhöhe 9 cm) betrieben werden.

Bei der Betriebsart S2 15 Minuten sowie bei der Betriebsart S3 20% mit einer Spieldauer von 10 Minuten muss mindestens das Pumpengehäuse komplett in das Fördermedium eingetaucht sein.

Die Einhaltung der Betriebsart S2 bzw. S3 ist durch die elektrische Steuerung zu gewährleisten. Bei Nichteinhaltung einer dieser Bedingungen für die entsprechende Betriebsart muss der Motor unverzüglich ausgeschaltet werden.

Type D 90 - 4 / 150 A

Leistung (Aufnahme):	5,82	380 - 420	655 - 725	kW
Spannung:	218 - 242		5,7	V
Strom:	17,0	9,8		A
Leistungsfaktor:	0,80			
Frequenz:	50 oder 60			Hz
Drehzahl:	1316 bzw. 1616			min-1
Fördermitteltemperatur:	max. 40			°C
Betriebsarten:	S1 für max. 11 cm ausgetauchten Motor, S2 7 min., S3 10 % ¹⁾			
¹⁾ Spieldauer	10 min.			

Die Bescheinigung gilt auch für Motoren mit einer geringeren Aufnahmeleistung, jedoch maximal bis zu einem Maximalwert von 5,82 kW.

Die entsprechenden Daten sind vom Hersteller auf dem Leistungsschild anzugeben.

Neben den oben angegebenen Spannungen sind auch dazwischenliegende Werte zulässig. Die zugehörigen Ströme sind im reziproken Verhältnis der Spannung umzurechnen.

Gegenüber den Bemessungswerten darf die Netzspannung bis zu ± 5 % und die Netzfrequenz bis zu ± 2 % entsprechend dem Bereich A nach IEC 60034-1 schwanken.

Die Bescheinigung gilt auch für Motoren, die mit 60 Hz betrieben werden. Hierbei darf die max. Leistung (Aufnahme) von $P_1 = 5,82$ kW nicht überschritten werden.

Temperaturüberwachung

Bei Motoren mit Kaltleiterschutz muss sichergestellt sein, dass bei festgebremstem Läufer und einem Verhältnis $I_n/I_N = 3,5$ die Auslösezeit $t_A = 26,7$ s mit einer Toleranz von ± 20 %

Seite 3/5

EU-Baumusterprüfbescheinigungen ohne Unterschrift und ohne Siegel haben keine Gültigkeit.
Diese EU-Baumusterprüfbescheinigung darf nur unverändert weiterverbreitet werden.
Auszüge oder Änderungen bedürfen der Genehmigung der Physikalisch-Technischen Bundesanstalt.
Physikalisch-Technische Bundesanstalt • Bundesallee 100 • 38116 Braunschweig • DEUTSCHLAND



Physikalisch-Technische Bundesanstalt
Braunschweig und Berlin
Nationales Metrologieinstitut



SCHEDULE TO EU-TYPE EXAMINATION CERTIFICATE PTB 08 ATEX 1113 X Issue : 01

The certificate is also valid for motors running with a frequency of 60 Hz. Hereby the max. current (input) of $P_1 = 6,00$ kW may not be exceeded.

Temperature monitoring

For motors with PTC thermistor has to be ensured that with a locked rotor and a ratio of $I_n/I_N = 4,4$, the release time $t_A = 27,7$ s will be maintained at a tolerance of ± 20 %. This applies for a cold motor (20 °C) and a rated voltage of 400 V at 50 Hz.

To avoid inadmissibly high temperatures on the motor part the following conditions have to be observed:

For operation in duty type S1 the operated motor has to be submerged in the medium (9 cm max. non-submerged).

For operation in duty type S2 15 minutes as well as for duty type S3 20 % with a cycle time of 10 minutes min. the pump housing has to be submerged completely in the medium.

Compliance of duty type S2 resp. S3 is ensured by an electrical control system. In case of non-compliance of one of these conditions for the corresponding duty type the motor has to be switched off immediately.

Type D 90 - 4 / 150 A

Power (input):	5,82	380 - 420	655 - 725	kW
Voltage:	218 - 242		5,7	V
Current:	17,0	9,8		A
Power factor:	0,80			
Frequency:	50 or 60			Hz
Speed:	1316 resp. 1616			min-1
Temperature of the medium:	max. 40			°C
Duty type:	S1 with max. 11 cm non-submerged motor, S2 7 min., S3 10 % ¹⁾			
¹⁾ cycle time	10 min.			

The certificate is also valid for motors with a lower power input, but up to 5,82 kW as a maximum.

The manufacturer has to specify the corresponding data on the nameplate.

In addition to the above-mentioned voltages, intermediate values are permissible. The associated currents are to be converted in the inverse ratio of the voltages.

The mains voltage may vary by up to ± 5 % and the mains frequency by up to ± 2 % from the rated values, in keeping with range A according to IEC 60034-1.

The certificate is also valid for motors which are run with a frequency of 60 Hz.

The max. power (input) of $P_1 = 5,82$ kW must not be exceeded.

sheet 3/5

EU-Type Examination Certificates without signature and official stamp shall not be valid. The certificates may be circulated only without alteration. Extracts or alterations are subject to approval by the Physikalisch-Technische Bundesanstalt.
In case of dispute, the German text shall prevail.

Physikalisch-Technische Bundesanstalt • Bundesallee 100 • 38116 Braunschweig • GERMANY

Anlage zur EU-Baumusterprüfbescheinigung PTB 08 ATEX 1113 X, Ausgabe: 01

eingehalten wird. Dabei ist vom kalten Motor (20°C) und einer Netzspannung 400 V bei 50 Hz auszugehen.

Zur Vermeidung unzulässig hoher Temperaturen am Motorteil sind folgende Bedingungen zu beachten:

In der Betriebsart S1 muss der Motor in das Fördermedium eingetaucht (max. Austauschhöhe 11 cm) betrieben werden.

Bei der Betriebsart S2 7 Minuten sowie bei der Betriebsart S3 10% mit einer Spieldauer von 10 Minuten muss mindestens das Pumpengehäuse komplett in das Fördermedium eingetaucht sein.

Die Einhaltung der Betriebsart S2 bzw. S3 ist durch die elektrische Steuerung zu gewährleisten. Bei Nichterhaltung einer dieser Bedingungen für die entsprechende Betriebsart muss der Motor unverzüglich ausgeschaltet werden.

(16) Prüfbericht PTB Ex 15-15108

(17) Besondere Bedingungen

Eine Reparatur an den zünddurchschlagsicheren Spalten darf nur entsprechend den konstruktiven Vorgaben des Herstellers erfolgen. Die Reparatur entsprechend den Werten der Tabelle 1 bzw. 2 der EN 60079-1 ist nicht zulässig.

Zusätzliche Hinweise für den sicheren Betrieb:

Für den Ein- und Anbau von Komponenten (Anschlussräume, Durchführungen, Ex-Kabel- und Leitungseinführungen, Anschlusssteile) sind nur solche zugelassen, die mindestens dem auf dem Deckblatt angegebenen Normenstand technisch entsprechen und für die eine gesonderte Prüfbescheinigung vorliegt. Die in den entsprechenden Bescheinigungen der Komponenten aufgeführten Einsatzbedingungen sind dabei unbedingt zu beachten und müssen mindestens den in der vorstehenden EG-Baumusterprüfbescheinigung spezifizierten Einsatzbedingungen entsprechen.

Für den Abschluss des druckfesten Raumes sind mindestens Schrauben der Festigkeitsklasse A2-70 zu verwenden.

1. Für den Betrieb am Netz

Die Motoren dieses Typs müssen zusätzlich zu thermisch verzögerten Überstromauslösern durch 2 Temperaturbegrenzer (150 ± 5°C) geschützt werden.

2. Für den Betrieb am Umrichter

2.1 Die Motoren müssen durch eine Einrichtung zur direkten Temperaturüberwachung geschützt werden. Diese besteht aus

in die Wicklung eingebauten Temperaturfühlern
(Kaltleiter DIN 44 082-150) und einem mindestens nach
Richtlinie 94/9/EG hierfür funktionsgeprüftem Auslösegerät.

Die Zusammengehörigkeit von Motor und Überwachungseinrichtung wird auf dem Motor durch ein Zusatzschild gekennzeichnet.

Seite 4/5

EU-Baumusterprüfbescheinigungen ohne Unterschrift und ohne Siegel haben keine Gültigkeit.
Diese EU-Baumusterprüfbescheinigung darf nur unverändert weiterverbreitet werden.
Auszüge oder Änderungen bedürfen der Genehmigung der Physikalisch-Technischen Bundesanstalt.
Physikalisch-Technische Bundesanstalt • Bundesallee 100 • 38116 Braunschweig • DEUTSCHLAND

SCHEDULE TO EU-TYPE EXAMINATION CERTIFICATE PTB 08 ATEX 1113 X Issue : 01

Temperature monitoring

For motors with PTC thermistor it has to be ensured that with a locked rotor and a ratio of $I_{L/N} = 3.5$, the release time $t_{a_0} = 26.7$ s will be maintained at a tolerance (± 20%). This applies for a cold motor (20 °C) and a rated voltage of 400 V at 50 Hz.

To avoid inadmissibly high temperatures on the motor the following conditions have to be observed:

In the duty type S1 the motor has to be submerged in the medium (max. 11 cm non-submerged) during operation.

In the duty type S2 7 minutes as well with duty type S3 10 % with a cycle time of 10 minutes at least the pump housing has to be submerged in the medium.

Compliance of duty type S2 resp. S3 has to be ensured by means of electrical control. In case of non-compliance with one of these conditions of the corresponding duty type the motor has to be switched off immediately.

(16) Test Report PTB Ex 15-15108

(17) Special conditions for safe use

Repairs of the flameproof joints must be made in compliance with the structural specifications provided by the manufacturer. Repairs must not be made on the basis of values specified in tables 1 and 2 of EN 60079-1.

Additional notes for safe operation

Components attached or installed (terminal compartments, bushings, 'Ex' cable glands, connectors) must be of a technical standard that at least complies with the specifications on the cover sheet and for which a separate examination certificate has been issued. The operating conditions specified in component certificates must be followed and they must as a minimum conform with the operating conditions specified in the above mentioned EC-Type Examination Certificate.

Screws complying with strength class A2-70 as a minimum must be used for enclosure of the flameproof chamber.

1. For mains operation

Motors of this type must be protected by two temperature limiters (150 ± 5 °C) in addition to thermally delayed overcurrent releases.

2. For converter operation

2.1 The motors must be protected by a device providing for direct temperature monitoring. This device will comprise:

temperature sensors embedded in the winding
(PTC resistor DIN 44 082-150) and a tripping device

sheet 4/5

EU-Type Examination Certificates without signature and official stamp shall not be valid. The certificates may be circulated only without alteration. Extracts or alterations are subject to approval by the Physikalisch-Technische Bundesanstalt. In case of dispute, the German text shall prevail.

Physikalisch-Technische Bundesanstalt • Bundesallee 100 • 38116 Braunschweig • GERMANY



Überstromschutzrichtungen mit stromabhängig verzögerter Auslösung sind hierbei als zusätzliche Überwachung anzusehen.

2.2 Die Motoren werden im Frequenzbereich von 15 Hz bis 50/60 Hz betrieben. Die Ausgangsspannung des Umrichters wird dabei so geregelt, dass im Bereich von 15 Hz bis 50/60 Hz eine annähernd lineare Abhängigkeit zwischen der Spannung und der Frequenz eingehalten wird, d.h. Einhaltung eines praktisch konstanten Maschinenflusses entsprechend den Bemessungsdaten.

Die Strombegrenzung des Umrichters wird höchstens auf den 3fachen Motorstrom eingestellt.

Zusatz- und Überwachungseinrichtungen mit eigener Bescheinigung und Explosionschutzkennzeichnung sind den am Einsatzort vorliegenden Bedingungen entsprechend auszuwählen.

Überwachungseinrichtungen müssen den Anforderungen nach Richtlinie 2014/34/EU und EN 1127-1 genügen.

Weitere einschränkende Hinweise für den sicheren Betrieb sind dem jeweiligen Datenblatt für die Maschinenauslegung zu entnehmen.

Elektrisch-thermische Motorauslegung

Die Datenblätter 01 bis 05 der EG-Baumusterprüfbescheinigung PTB 02 ATEX 1042 sind gleichzeitig Bestandteil der vorstehenden EG-Baumusterprüfbescheinigung.

(18) Grundlegende Sicherheits- und Gesundheitsanforderungen

Erfüllt durch Übereinstimmung mit den vorgenannten Normen.

Nach Artikel 41 der Richtlinie 2014/34/EU dürfen EG-Baumusterprüfbescheinigungen nach Richtlinie 94/9/EG, die bereits vor dem Datum der Anwendung von Richtlinie 2014/34/EU (20. April 2016) bestanden, so betrachtet werden, als wenn sie bereits in Übereinstimmung mit der Richtlinie 2014/34/EU ausgestellt wurden. Mit Genehmigung der Europäischen Kommission dürfen Ergänzungen zu solchen EG-Baumusterprüfbescheinigungen und neue Ausgaben solcher Zertifikate weiterhin die vor dem 20. April 2016 ausgestellte originale Zertifikatsnummer tragen.

Konformitätsbewertungsstelle, Sektor Explosionsschutz

Braunschweig, 21. Juni 2016

Im Auftrag

Dr.-Ing. U. Klausmeyer
Direktor und Professor



EU-Baumusterprüfbescheinigungen ohne Unterschrift und ohne Siegel haben keine Gültigkeit.
Diese EU-Baumusterprüfbescheinigung darf nur unverändert weiterverbreitet werden.
Auszüge oder Änderungen bedürfen der Genehmigung der Physikalisch-Technischen Bundesanstalt.
Physikalisch-Technische Bundesanstalt • Bundesallee 100 • 38116 Braunschweig • DEUTSCHLAND



SCHEDULE TO EU-TYPE EXAMINATION CERTIFICATE

PTB 08 ATEX 1113 X Issue : 01

being at least function tested in accordance with Directive 94/9/EC.

The concerted operation of motor and monitoring device will be indicated by a plate additionally provided on the motor.

Overcurrent protection devices with current-based delayed tripping must in this context be regarded as additional monitoring devices.

2.2 The motors will be operated within the 15-Hz to 50/60-Hz frequency range. The converter output voltage will be controlled so that within the 15-Hz to 50/60-Hz range an approximately linear relationship between voltage and frequency will be maintained, i.e. that a basically constant machine flow in compliance with the ratings will be maintained.

The converter current limitation will be set at three times the motor current as a maximum.

Supplementary and monitoring devices with their own certificate and explosion protection marking have to be selected so that they comply with the conditions at the place of installation.

Monitoring devices must satisfy the requirements in Directives 2014/34/EU and EN 1127-1.

For any additional notes concerning restrictions for safe use, reference is made to the data sheet for the machine design.

Electro-thermal motor design

Data sheets 01 to 05 of EC Type Examination Certificate PTB 02 ATEX 1042 also form part of the above mentioned EC-Type Examination Certificate.

(18) Essential health and safety requirements

Met by compliance with the afore-mentioned Standards.

According to Article 41 of Directive 2014/34/EU, EC-type examination certificates which have been issued according to Directive 94/9/EC prior to the date of coming into force of Directive 2014/34/EU (April 20, 2016) may be considered as if they were issued already in compliance with Directive 2014/34/EU. By permission of the European Commission supplements to such EC-Type examination certificates and new issues of such certificates may continue to hold the original certificate number issued before April 20, 2016.

Konformitätsbewertungsstelle, Sektor Explosionsschutz
On behalf of PTB:

Braunschweig, June 21, 2016

Dr.-Ing. U. Klausmeyer
Direktor und Professor



EU-Type Examination Certificates without signature and official stamp shall not be valid. The certificates may be circulated only without alteration. Extracts or alterations are subject to approval by the Physikalisch-Technische Bundesanstalt. In case of dispute, the German text shall prevail.

Physikalisch-Technische Bundesanstalt

Braunschweig und Berlin

Datenblatt 03 zur EG-Baumusterprüfbescheinigung PTB 02 ATEX 1042

der Firma Jung Pumpen GmbH & Co., 33803 Steinhagen, Deutschland

für den Tauchpumpenmotor Typ D 90 - 2 / 110 C bzw. D 90 - 2 / 110 CK

Bemessungsgrößen und Daten

Diese Bescheinigung gilt unter der Voraussetzung, dass sich die Motoren dieses Typs hinsichtlich der elektrischen und thermischen Beanspruchungen nur unwesentlich von dem geprüften Muster unterscheiden, für die folgenden Ausführungen:

Leistung (Aufnahme):	4,84	KW		
Spannung:	218 - 242	380 - 420	655 - 725	V
Strom:	13,7	7,9	4,6	A
Leistungsfaktor:	0,90 - 0,85			
Frequenz:	50 oder 60			
Drehzahl:	2819 bzw. 3419			
Umgebungstemperatur:	max. 40			
I_M/I_N :	5,6			

Betriebsart: S1 bei eingetauchtem Motorteil, S2 14 min., S3 25 %¹⁾

¹⁾ Spieldauer 10 min.

Die Bescheinigung gilt auch für Motoren mit einer geringeren Leistung, jedoch maximal bis zu 4,84 kW Aufnahmeleistung.

Die entsprechenden Daten sind vom Hersteller auf dem Leistungsschild anzugeben.

Gegenüber den Bemessungswerten darf die Netzspannung bis zu $\pm 5\%$ und die Netzfrequenz bis zu $\pm 2\%$ entsprechend dem Bereich A nach IEC 34-1 schwanken.

Temperaturüberwachung

Bei Motoren mit Kaltleiterschutz muss sichergestellt sein, dass bei festgebremstem Läufer und einem Verhältnis $I_M/I_N = 5,6$ die Auslösezeit $t_A = 23,4$ s mit einer Toleranz von $\pm 20\%$ eingehalten wird. Dabei ist vom kalten Motor (20°C) und einer Netzspannung 400 V bei 50 Hz auszugehen.

Zur Vermeidung unzulässig hoher Temperaturen am Motorteil sind folgende Bedingungen zu beachten: Bei der Betriebsart S1 muss sichergestellt werden, dass der komplette Motor in das Fördermedium eingetaucht ist.

Bei der Betriebsart S2 14 Minuten sowie bei der Betriebsart S3 25% mit einer Spieldauer von 10 Minuten muss mindestens das Pumpengehäuse komplett in das Fördermedium eingetaucht sein.

Die Einhaltung der Betriebsart S2 bzw. S3 ist durch die elektrische Steuerung zu gewährleisten. Bei Nichteinhaltung einer dieser Bedingungen für die entsprechende Betriebsart, muss der Motor unverzüglich ausgeschaltet werden.

Prüfbericht PTB Ex 02-32109

Zertifizierungsstelle Explosionsschutz
im Auftrag



Dr.-Ing. U. Engel
Regierungsdirektor

Braunschweig, 30. Mai 2002

Blatt 1/1

Physikalisch-Technische Bundesanstalt

Braunschweig und Berlin

DATA SHEET 03 TO EC-TYPE-EXAMINATION CERTIFICATE PTB 02 ATEX 1042

Manufacturer: Jung Pumpen GmbH & Co., 33803 Steinhagen, Germany

for the submersible-pump motor type D 90 - 2 / 110 C or D 90 - 2 / 110 CK

Ratings

This certificate is valid for the following designs providing the motors of this type differ only negligibly from the sample tested as regards the electrical and thermal stresses:

Power (input):	4,84	KW		
Voltage:	218 - 242	380 - 420	655 - 725	V
Current:	13,7	7,9	4,6	A
Power factor:	0,90 - 0,85			
Frequency:	50 or 60			
Speed:	2819 or 3419			
temperature of cooling medium:	max. 40			
I_M/I_N ratio:	5,6			

Duty Type: S1 with immersed motor section, S2 14 min., S3 25%¹⁾

¹⁾ cycle time 10 min.

The certificate is also valid for motors with a lower power input, but up to 4,84 kW as a maximum. The manufacturer must state the corresponding data on the nameplate.

The mains voltage may vary by up to $\pm 5\%$ and the mains frequency by up to $\pm 2\%$ from the rated values, in keeping with range A according to IEC 34-1.

Temperature monitoring

For motors with PTC thermistor are to be ensured that with a locked rotor and a ratio of $I_M/I_N = 5,6$, the release time $t_A = 23,4$ s will be maintained at a tolerance of $\pm 20\%$. This applies for a cold motor (20°C) and a rated voltage of 400 V at 50 Hz.

To avoid inadmissibly high temperatures on the motor the following conditions are to be considered:

For duty type S1 it must be ensured that the complete motor is immersed into the cooling medium. For duty type S2 14 minutes as well as for duty type S3 25% with a cycle time of 10 minutes the pump case must be complete immersed into the cooling medium.

The adherence to the duty type S2 and/or S3 is to be ensured by the electrical control.

During disregard one of these conditions for the respective duty type, the motor must be switched off immediately.

Report PTB Ex 02-32109

Zertifizierungsstelle Explosionsschutz
By order





Dr.-Ing. U. Engel
Regierungsdirektor

Braunschweig, May 30, 2002

page 1/1

TECHNISCHE DATEN | TECHNICAL DATA | CARACTÉRISTIQUES
TECHNIQUES | TECHNISCHE GEGEVENS | DATI TECNICI | DANE NICZNE

		35/2 M TAN, EX	36/2 M TAN, EX	45/2 TAN, EX
	[kg]	95	95	98
	PN 6	DN 32	DN 32	DN 32
	[mm]	7	7	7
	S2	27 min.	20 min.	14 min.
	S3*	40 %	30 %	25 %
Motor		D 90-2/110	D 90-2/110	D 90-2/110
	PTB 08	ATEX 1113X 01	ATEX 1113X 01	ATEX 1113X 01
	 II 2 G	Ex db IIB T4 Gb	Ex db IIB T4 Gb	Ex db IIB T4 Gb
P1	[kW]	2 x 3,7	2 x 4,2	2 x 4,84
P2	[kW]	2 x 3,1	2 x 3,42	2 x 3,93
U	[V]	3/PE ~400	3/PE ~400	3/PE ~400
f	[Hz]	50	50	50
I	[A]	2 x 6,6	2 x 7,3	2 x 7,9
cos phi		0,82	0,84	0,86
n	[min ⁻¹]	2896	2880	2895

* Beispiel: 40%: 4 min Betrieb + 6 min Pause (Spieldauer 10 min) * Example for 40%: 4 min. operation and 6 min. rest (Cycle duration 10 min.)

* Exemple: 40% = 4 min de service et 6 min de pause (Durée du jeu 10 min) * Eksempel: 40 %: 4 min drift + 6 min pause (spilletid 10 min)

* Esempio: 40%: 4 min. di funzionamento + 6 min. di pausa (durata del ciclo 10 min.) * Przykładowo 40%: 4 min pracy i 6 min przerwy (Czas cyklu 10 min)

Leistung • Performance • Puissances • Capaciteit • Prestazioni • Wydajności i moce

H [m]	40	44	48	52	56	60	64	68	72	76	80	84
35/2 M Tan	16	15	13,5	11,5	9,5	7	4	1				
36/2 M Tan			16	15	13	11	9	6,5	3,5			
45/2 M Tan									10	8	5	2
												Q [m ³ /h]

MULTICUT TANDEM

Ersatzteile - Spare parts - Pièces de rechange - Reserveonderdelen - Parti di ricambio - Reservedele - Reservdelar
 Varaosat - Części zamienne - Náhradní díly - Alkatrészek - Piese de schimb - Запасные части - 备件

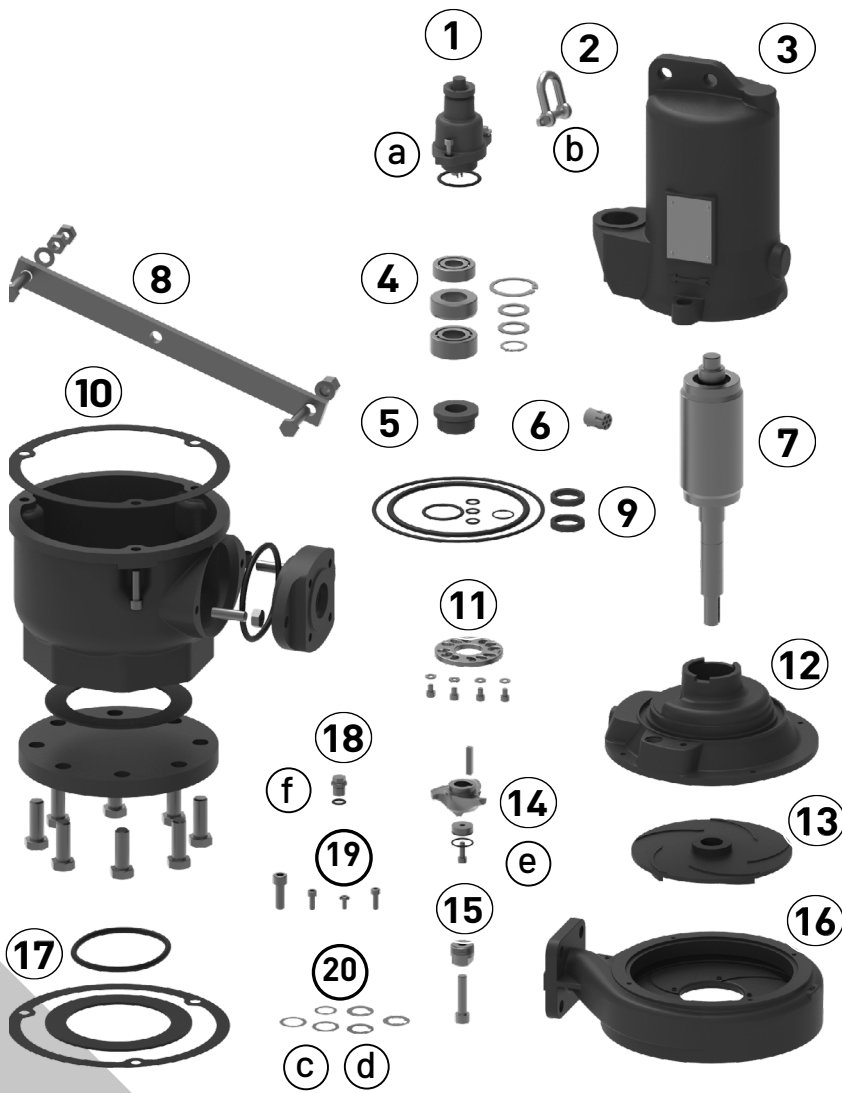

①	Leitung	Cable	
	10m		JP45469
	15m		JP45583
	20m		JP45584
②	Schäkel	Shackle	JP45904
③	Stator + Gehäuse	Stator + Housing	JP46211
④	Lagersatz	Bearing set	JP46214
⑤	Gleitringdichtung	Mechanical seal	JP46567
⑥	Steckverbinder	Connector	
	35/2, 36/2		JP46572
	45/2		JP46573
⑦	Rotorwelle	Rotor shaft	JP46564
⑧	Befestigungsschiene	Connection rail	JP46228
⑨	Dichtungssatz	Seal set	JP46215
⑩	Zwischenflansch	Connecting flange	JP46227
⑪	Schneidplatte	Cutter plate	JP50324
⑫	Lagerkammer	Bearing housing	
	35/2, 36/2		JP46216
	45/2		JP46217
⑬	Lauftrad	Impeller	
	35/2		JP46218
	36/2		JP46219
	45/2		JP46220
⑭	Schneidrotor	Cutter	JP50326
⑮	Abziehwerkzeug	Pulling device for cutting system	JP50325
⑯	Pumpengehäuse	Pump casing	
	35/2, 36/2		JP46226
	45/2		JP48405
⑰	Dichtungssatz Zw.Fl.	Seal set con. flange	JP47398
⑱	Ölschraube	Oil screw	JP46046
⑲	Schraubensatz	Screw set	JP46563
⑳	Passscheiben	Shim rings	JP46571
㉑	1l Öl	1l Oil	JP48236

a	10x O-Ring 38x3,5	JP48109
b	10x Splint / Cotter pins 1,6 x 20	JP46182
c	10x Scheibe / Shim ring 18x25x0,2	JP48111
d	10x Scheibe / Shim ring 18x30x0,1	JP48085
	10x Scheibe / Shim ring 18x30x0,2	JP48086
	10x Scheibe / Shim ring 18x30x0,3	JP48087
e	10x O-Ring 21x2	JP50323
f	10x O-Ring 10x2,5	JP48088



**PUMP TECHNICAL
SERVICES LIMITED**



THE SUBMERSIBLE PUMP SPECIALISTS

✉ service@pts-jung.co.uk

✉ sales@pts-jung.co.uk

Pump House
Unit 12
Bilton Road Industrial Estate
Erith, Kent, DA8 2AN

☎ 01322 357 080

🌐 pts-jung.co.uk