



**PUMP TECHNICAL
SERVICES LIMITED**



THE SUBMERSIBLE PUMP SPECIALISTS

MANUFACTURING | SALES | PROJECT DESIGN | INSTALLATION | MAINTENANCE AND REPAIRS

MULTIDRAIN

UV 305-1	UV 310-1	UV 315-1
UV 305-1 S	UV 310-1 S	UV 315-1 S
UV 305-3	UV 310-3	UV 315-3
UV 305-3 S	UV 310-3 S	UV 315-3 S

EN Instruction Manual

Pump House
Unit 12
Bilton Road Industrial Estate
Erith, Kent, DA8 2AN

 service@pts-jung.co.uk

 01322 357 080

 sales@pts-jung.co.uk

 pts-jung.co.uk

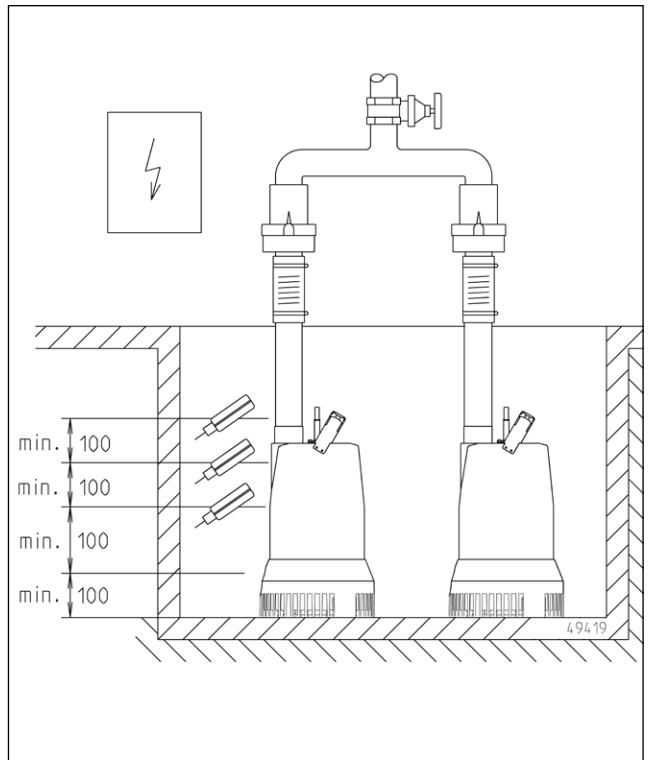
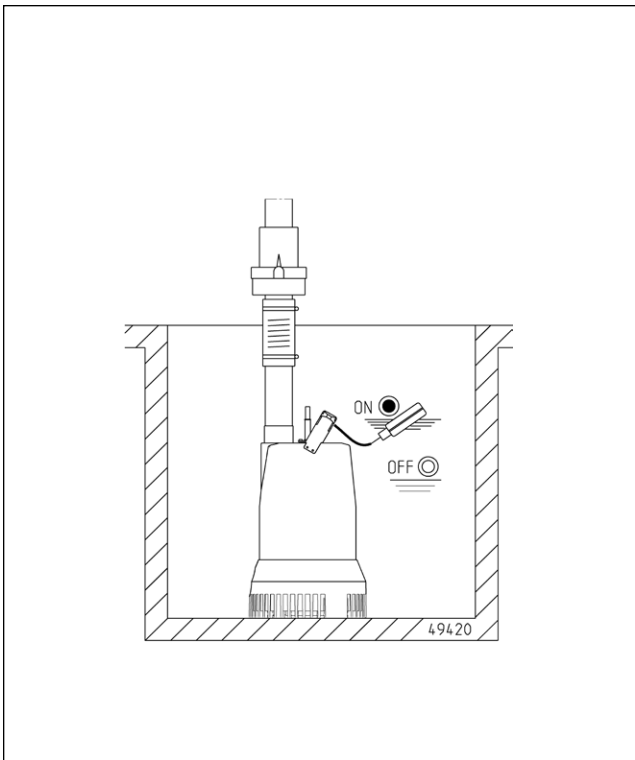
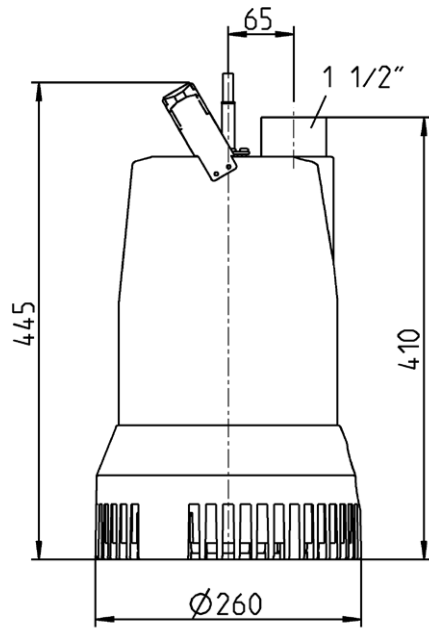

You have purchased a product made by Pentair Jung Pumpen and with it, therefore, also excellent quality and service. Secure this service by carrying out the installation works in accordance with the instructions, so that our product can perform its task to your complete satisfaction. Please remember that damage caused by incorrect installation or handling will adversely affect the guarantee.

This appliance can be used by children aged 8 years or over and by persons with limited physical, sensory or intellectual capabilities, or with limited experience and knowledge, provided that they are supervised or have been instructed in the safe use of the appliance and are aware of the dangers involved. Children must not be allowed to play with the appliance. Cleaning and user maintenance must not be carried out by children unless they are supervised.

If this unit is equipped with a mains connection line without a plug or other means of disconnection from the mains, a complete disconnecting device must be installed on site in the fixed electrical installation in accordance with the installation regulations. A main switch of overvoltage category III can be installed as a complete disconnecting device. If the mains connection cable of this unit is damaged, it must be replaced by the manufacturer or its customer service or a similarly qualified person in order to avoid hazards.

Damage prevention in case of failure

Like any other electrical device, this product may fail due to a lack of mains voltage or a technical defect.

If damage (including consequential damage) can occur as a result of product failure, the following precautions can be taken at your discretion:

- Installation of a water level dependent (under circumstances, mains-independent) alarm system, so that the alarm can be heard before damage occurs.
- Inspection of the collecting tank/chamber for tightness up to the top edge before – or at the latest, during – installation or operation of the product.
- Installation of backflow protection for drainage units that can be damaged by wastewater leakage upon product failure.
- Installation of a further product that can compensate in case of failure of the other product (e.g. duplex unit).
- Installation of an emergency power generator.

As these precautions serve to prevent or minimise consequential damage upon product failure, they are to be strictly observed as the manufacturer's guideline – in line with the standard DIN EN specifications as state of the art – when using the product (Higher Regional Court Frankfurt/Main, Ref.: 2 U 205/11, 06/15/2012).

SAFETY INSTRUCTIONS

This instruction manual contains essential information that must be observed during installation, operation and servicing. It is therefore important that the installer and the responsible technician/operator read this instruction manual before the equipment is installed and put into operation. The manual must always be available at the location where the pump or the plant is installed.

Failure to observe the safety instructions can lead to the loss of all indemnity.

In this instruction manual, safety information is distinctly labelled with particular symbols. Disregarding this information can be dangerous.



General danger to people



Warning of electrical voltage

NOTICE! Danger to equipment and operation

Qualification and training of personnel

All personnel involved with the operation, servicing, inspection and installation of the equipment must be suitably qualified for this work and must have studied the instruction manual in depth to ensure that they are sufficiently conversant with its contents. The supervision, competence and areas of responsibility of the personnel must be precisely regulated by the operator. If the personnel do not have the necessary skills, they must be instructed and trained accordingly.

Safety-conscious working

The safety instructions in this instruction manual, the existing national regulations regarding accident prevention, and any internal working, operating and safety regulations must be adhered to.

Safety instructions for the operator/user

All legal regulations, local directives and safety regulations must be adhered to.

The possibility of danger due to electrical energy must be prevented.

Leakages of dangerous (e.g. explosive, toxic, hot) substances must be discharged such that no danger to people or the environment occurs. Legal regulations must be observed.

Safety instructions for installation, inspection and maintenance works

As a basic principle, works may only be carried out to the equipment when it is shut down. Pumps or plant that convey harmful substances must be decontaminated.

All safety and protection components must be re-fitted and/or made operational immediately after the works have been completed. Their effectiveness must be checked before restarting, taking into account the current regulations and stipulations.

Unauthorised modifications, manufacture of spare parts

The equipment may only be modified or altered in agreement with the manufacturer. The use of original spare parts and accessories approved by the manufacturer is important for safety reasons. The use of other parts can result in liability for consequential damage being rescinded.

Unauthorised operating methods

The operational safety of the supplied equipment is only guaranteed if the equipment is used for its intended purpose. The

limiting values given in the "Technical Data" section may not be exceeded under any circumstances.

Instructions regarding accident prevention

Before commencing servicing or maintenance works, cordon off the working area and check that the lifting gear is in perfect condition.

Never work alone. Always wear a hard hat, safety glasses and safety shoes and, if necessary, a suitable safety belt.

Before carrying out welding works or using electrical devices, check to ensure there is no danger of explosion.

People working in wastewater systems must be vaccinated against the pathogens that may be found there. For the sake of your health, be sure to pay meticulous attention to cleanliness wherever you are working.

Make sure that there are no toxic gases in the working area.

Observe the health and safety at work regulations and make sure that a first-aid kit is to hand.

In some cases, the pump and the pumping medium may be hot and could cause burns.

For installations in areas subject to explosion hazards, special regulations apply!

APPLICATION



DANGER!

The pump must never be used when a person is in the water.

Submersible pumps of the MultiDrain series are suitable for pumping wastewater, rainwater, groundwater, seepage water or drainage water with admixtures of up to 10 mm grain size.

Use of the pumps is subject to relevant national laws, regulations and local requirements such as:

- Domestic contaminated water and waste water (e.g. EN 12056 in Europe)
- Installation of low voltage systems (e.g. VDE 0100 in Germany)

For non-standard utilisation conditions, further regulations must be observed (e.g. VDE 0100 in Germany, part 701: bathrooms and shower rooms; part 702: Swimming pools and fountains; part 704: Construction sites and part 737: outdoor use).

Temperatures

Motor at the surface: continuous operation S1

The pumped medium must have a temperature of max 40°C.

The submersible pump is frost-resistant down to -20°C when stored in dry conditions. When installed, however, it must not be allowed to freeze in the water.

Transport

The pump must always be lifted by the handle and never by the power supply cable! The pump should only be lowered into deeper chambers or pits using a chain.

ELECTRICAL CONNECTION

NOTICE! Only qualified electricians may carry out electrical work on the pump, plug or the control unit.

The pump must only be connected to circuits that have been installed properly in accordance with the regulations and are protected with at least 10 A (slow) and RCD-safety switches (30mA).

Current applicable standards (such as EN standards), national regulations (such as VDE in Germany), and the regulations of the local power supply companies must be complied with.

Some types are supplied with an open cable end. To connect to the power supply, a control unit or a nationally approved plug with a protective earth contact must be used.

NOTICE! Never put the mains plug or a free lead end in water! If water gets into it, this can cause malfunctions and damage.

Observe the operating voltage (see type plate)!

The pump is provided with a winding thermostat. In case of unacceptably high temperatures, it switches off the pump to protect it against possible damage. Unacceptably high temperatures may result e.g. from dry running or mechanical or electrical overload.



CAUTION!

The pump is switched on again automatically after cooling down - risk of injury!

For this reason, always disconnect the device from the mains before remedying the fault! In order to do this, unplug from the mains supply or remove the pre-fuses of the pump controls!

Pumps without built-in level control can also be operated automatically through the use of our level controls.

Rotational direction

The rotational direction must be checked before installation! If the rotational direction is correct, the start-up jolt should be in the opposite direction to the rotational direction arrow on the motor housing. The wrong rotational direction is also indicated if the pump performs inadequately when installed, or if loud noises can be heard during operation. If the rotational direction is wrong, 2 phases of the supply cable must be swapped over.



CAUTION!

The start-up jolt can be very forceful.

INSTALLATION

The pump must be installed as shown in the examples. For installations in accordance with EN 12056-4, the pressure pipe must be laid in a loop above the local backflow level and protected with a non-return valve in accordance with EN 12050-4.

A correspondingly larger diameter pipe should be used for longer pressure pipelines to avoid pipe friction losses.

The MultiDrain pumps have a vertical discharge branch.

In contrast to pumps with built-in level control, the ON and OFF switching heights of pumps without built-in level control are variable by the use of a separate level control.

NOTICE! If the pump is malfunctioning, part of the contents of the oil reservoir could escape into the pumping medium.

Dimensions of sump

Single installation: 40 x 50 cm

Duplex installation: 40 x 70 cm

NOTICE! The floats of the level control and alarm system are installed so that they are freely movable but not under the inlet. Please observe the minimum distances. The controls must only be installed in a dry and well ventilated room!

MAINTENANCE

Maintenance and inspection of this product must be carried out in accordance with EN 12056-4.

To ensure continued reliability of service, we recommend that you take out a service contract.



DANGER!

Before carrying out any work: Disconnect the pump and the control unit from the mains power supply and take action to ensure that no one else can reconnect them to the power supply.



WARNING!

Check the plug and the mains cable for signs of mechanical and chemical damage. Damaged or kinked cables must be replaced by the manufacturer.

NOTICE! When using a chain to lift the pump, please observe the relevant national regulations regarding accident prevention. Lifting gear must be checked regularly by an expert in accordance with the legal regulations.

Cleaning

The inlet strainer prevents coarse dirt from entering the pump. Regular cleaning of the float and the foot strainer ensures optimum performance and operation.

If the impeller needs to be cleaned due to blocking or clogging, remove the screws on the underside of the pump and then remove the foot strainer.

Tightening torque M_A for A2 screw materials

M 6 $M_A = 8 \text{ Nm}$,

M 8 $M_A = 20 \text{ Nm}$,

M 10 $M_A = 40 \text{ Nm}$,

M 12 $M_A = 70 \text{ Nm}$,

foot strainer $M_A = 3 \text{ Nm}$.

QUICK TIPS FOR REMEDYING FAULTS

Pump does not work

- Check mains current (do not use a pin gauge)
- Fuse faulty = may be too weak (please refer to Electrical Connection)
- Mains supply cable damaged = repair to be carried out by manufacturer only

Pump runs but does not pump

- Empty the pressure pipe or hose to allow the non-return valve to open and the air to escape from the pump housing.

Impeller blocked

- Solids and fibrous matter have become lodged in the pump housing = clean

Decreased pumping performance

- Foot strainer obstructed = clean
- Pump housing obstructed = clean
- Impeller worn = replace
- Wrong direction of rotation (for a three-phase current) = ask a qualified electrician to change 2 phases of the supply line

EU-Konformitätserklärung
EU-Prohlášení o shodě
EU-Overensstemmelseserklæring
EU-Declaration of Conformity
EU-Vaatumustenmukaisuusvakuutus

EU-Déclaration de Conformité
EU-Megfelelőségi nyilatkozat
EU-Dichiarazione di conformità
EU-Conformiteitsverklaring
EU-Deklaracja zgodności

EU-Declarație de conformitate
EU-Vyhlášení o zhode
EU-Försäkran om överensstämmelse

DE - Richtlinien - Harmonisierte Normen
CS - Směrnice - Harmonizované normy
DA - Direktiv - Harmoniseret standard
EN - Directives - Harmonised standards
FI - Direktiivi - Yhdenmukaistettu standardi

FR - Directives - Normes harmonisées
HU - Irányelve - Harmonizált szabványok
IT - Direttive - Norme armonizzate
NL - Richtlijnen - Geharmoniseerde normen
PL - Dyrektywy - Normy zharmonizowane

RO - Directivă - Norme coroborate
SK - Smernice - Harmonizované normy
SV - Direktiv - Harmoniserade normer

- 2006/42/EG (MD) EN 809:1998/AC:2010, EN ISO 12100:2010, EN 60335-1:2012/A13:2017
- 2011/65/EU (RoHS)
- 2014/30/EU (EMC) EN 55014-1:2017/A11:2020, EN 55014-2:1997/A2:2008, EN 60034-1:2010/AC:2010
EN 61000-3-2:2014, EN 61000-3-3:2013

JUNG PUMPEN GmbH - Industriestr. 4-6 - 33803 Steinhagen - Germany - www.jung-pumpen.de

DE - Wir erklären in alleiniger Verantwortung, dass das Produkt den aufgeführten Richtlinien entspricht.
CS - Prohlašujeme na svou výlučnou odpovědnost, že výrobek odpovídá jmenovaným směrnicím.
DA - Vi erklærer under ansvar at produktet i overensstemmelse med de retningslinjer
EN - We hereby declare, under our sole responsibility, that the product is in accordance with the specified Directives.
FI - Me vakuutamme omalla vastuullamme, että tuote täyttää ohjeita.
FR - Nous déclarons sous notre propre responsabilité que le produit répond aux directives.
HU - Kizárólagos felelősségünk tudatában kijelentjük, hogy ez a termék megfelel az Európai Unió fentvezetett irányelveinek.
IT - Noi dichiariamo sotto la nostra esclusiva responsabilità che il prodotto è conforme alle direttive citate
NL - Wij verklaren geheel onder eigen verantwoordelijkheid dat het product voldoet aan de gestelde richtlijnen.
PL - Z pełną odpowiedzialnością oświadczamy, że produkt odpowiada postanowieniom wymienionych dyrektyw.
RO - Declarăm pe proprie răspundere că produsul corespunde normelor prevăzute de directivele mai sus menționate.
SK - Na výlučnú zodpovednosť vyhlasujeme, že výrobok spĺňa požiadavky uvedených smerníc.
SV - Vi försäkrar att produkten på vårt ansvar är utförd enligt gällande riktlinjer.

UV 305-1S (JP48693) UV 310-1S (JP48697) UV 315-1S (JP48701) UV 620-1S (JP47338)
UV 305-3S (JP48694) UV 310-3S (JP48698) UV 315-3S (JP48702)

DE - Weitere normative Dokumente CS - Jinými normativními dokumenty DA - Andre normative dokumenter EN - Other normative documents FI - Muiden normien FR - Autres documents normatifs HU - Egyéb szabályozó dokumentumokban leírtaknak IT - Altri documenti normativi NL - Verdere normatieve documenten PL - Innymi dokumentami normatywnymi RO - Alte acte normative SK - Iným záväzným dokumentom SV - Vidare normerande dokument:
EN 60335-2-41:2021/A11:2021
EN 62233:2008/AC:2008

DE - Bevollmächtigter für technische Dokumentation CS - Oprávněná osoba pro technickou dokumentaci DA - Autoriseret person for teknisk dokumentation EN - Authorized person for technical documentation FI - Valtuutettu henkilö tekninen dokumentaatio FR - Personne autorisée à la documentation technique HU - Hivatalos személy műszaki dokumentáció IT - Persona abilitata per la documentazione tecnica NL - Bevoegd persoon voor technische documentatie PL - Pełnomocnik ds. dokumentacji technicznej RO - Persoană autorizată pentru documentația tehnică SK - Oprávněná osoba pro technickou dokumentaci SV - Auktoriserad person för teknisk dokumentation:
JUNG PUMPEN - Stefan Sirges - Industriestr. 4-6 - 33803 Steinhagen

Steinhagen, 02-11-2022

Stefan Sirges, General Manager

i.V. Pascal Kölkebeck, Sales Manager

EU-Konformitätserklärung
EU-Prohlášení o shodě
EU-Overensstemmelseserklæring
EU-Declaration of Conformity
EU-Vaatumustenmukaisuusvakuutus

EU-Déclaration de Conformité
EU-Megfelelőségi nyilatkozat
EU-Dichiarazione di conformità
EU-Conformiteitsverklaring
EU-Deklaracja zgodności

EU-Declaratie de conformitate
EU-Vyhlasenie o zhode
EU-Försäkran om överensstämmelse

DE - Richtlinien - Harmonisierte Normen
 CS - Směrnice - Harmonizované normy
 DA - Direktiv - Harmoniseret standard
 EN - Directives - Harmonised standards
 FI - Direktiivi - Yhdenmukaistettu standardi

FR - Directives - Normes harmonisées
 HU - Irányelve - Harmonizált szabványok
 IT - Direttive - Norme armonizzate
 NL - Richtlijnen - Geharmoniseerde normen
 PL - Dyrektywy - Normy zharmonizowane

RO - Directivă - Norme coroborate
 SK - Smernice - Harmonizované normy
 SV - Direktiv - Harmoniserade normer

- **2006/42/EG** (MD) **EN 809:1998/AC:2010, EN ISO 12100:2010, EN 60335-1:2012/A13:2017**
- **2011/65/EU** (RoHS)
- **2014/30/EU** (EMC) **EN 55014-1:2017/A11:2020, EN 55014-2:1997/A2:2008, EN 60034-1:2010/AC:2010**
EN 61000-3-2:2014, EN 61000-3-3:2013

JUNG PUMPEN GmbH - Industriestr. 4-6 - 33803 Steinhagen - Germany - www.jung-pumpen.de

DE - Wir erklären in alleiniger Verantwortung, dass das Produkt den aufgeführten Richtlinien entspricht.
 CS - Prohlašujeme na svou výlučnou odpovědnost, že výrobek odpovídá jmenovaným směrnici.
 DA - Vi erklærer under ansvar at produktet i overensstemmelse med de retningslinjer
 EN - We hereby declare, under our sole responsibility, that the product is in accordance with the specified Directives.
 FI - Me vakuutamme omalla vastuullamme, että tuote täyttää ohjeita.
 FR - Nous déclarons sous notre propre responsabilité que le produit répond aux directives.
 HU - Kizárólagos felelősségünk tudatában kijelentjük, hogy ez a termék megfelel az Európai Unió fentnevezett irányelveinek.
 IT - Noi dichiariamo sotto la nostra esclusiva responsabilità che il prodotto è conforme alle direttive citate
 NL - Wij verklaren geheel onder eigen verantwoordelijkheid dat het product voldoet aan de gestelde richtlijnen.
 PL - Z pełną odpowiedzialnością oświadczamy, że produkt odpowiada postanowieniom wymienionych dyrektyw.
 RO - Declaram pe proprie răspundere că produsul corespunde normelor prevăzute de directivele mai sus menționate.
 SK - Na výlučnú zodpovednosť vyhlasujeme, že výrobok spĺňa požiadavky uvedených smerníc.
 SV - Vi försäkrar att produkten på vårt ansvar är utförd enligt gällande riktlinjer.

US 152 E (JP09435)	US 151 E (JP09310)	UV 305-1 (JP48691)	UV 620-1 (JP47337)
US 152 D (JP09437)	US 151 D (JP09300)	UV 305-3 (JP48692)	UV 620-3 (JP47339)
US 153 E (JP09311/1)	US 251 D (JP09301)	UV 310-1 (JP48695)	UV 620-3S (JP47340)
US 153 D (JP09302/1)	US 253 D (JP09303)	UV 310-3 (JP48696)	UV 625-3 (JP47341)
US 155 E (JP09388)		UV 315-1 (JP48699)	UV 625-3S (JP47342)
US 155 D (JP09390)		UV 315-3 (JP48700)	UV 635-3 (JP47343)
			UV 635-3S (JP47344)

DE - Weitere normative Dokumente CS - Jinými normativními dokumenty DA - Andre normative dokumenter EN - Other normative documents FI - Muiden normien FR - Autres documents normatifs HU - Egyéb szabályozó dokumentumokban leírtaknak IT - Altri documenti normativi NL - Verdere normatieve documenten PL - Innymi dokumentami normatywnymi RO - Alte acte normative SK - Iným záväzným dokumentom SV - Vidare normerande dokument:
EN 62233:2008/AC:2008

DE - Bevollmächtigter für technische Dokumentation CS - Oprávněná osoba pro technickou dokumentaci DA - Autoriseret person for teknisk dokumentation EN - Authorized person for technical documentation FI - Valtuutettu henkilö tekninen dokumentaatio FR - Personne autorisée à la documentation technique HU - Hivatalos személyi műszaki dokumentáció IT - Persona abilitata per la documentazione tecnica NL - Bevoegd persoon voor technische documentatie PL - Pełnomocnik ds. dokumentacji technicznej RO - Persoană autorizată pentru documentație tehnică SK - Oprávněná osoba pre technickú dokumentáciu SV - Auktoriserad person för teknisk dokumentation:
 JUNG PUMPEN - Stefan Sirges - Industriestr. 4-6 - 33803 Steinhagen

Steinhagen, 02-11-2022

 Stefan Sirges, General Manager

 i.V. Pascal Kölkebeck, Sales Manager



UKCA-Declaration of Conformity

Legislation - Designated Standards

- **Supply of Machinery (Safety) Regulations 2008 (MD)** EN 809:1998/AC:2010, EN ISO 12100:2010, 60335-1:2012/A13:2107
- **The Restriction of the Use of Certain Hazardous Substance in Electrical and Electronic Equipment Regulations 2012 (RoHS)**
- **Electromagnetic Compatibility Regulations 2016 (EMC)** EN 55014-1: 2017/A11:2020, EN 55014-2:1997/A2:2008, EN 60034-1: 2010/AC: 2010, EN 61000-3-2:2014, EN 61000-3-3:2013

Name and address of the manufacturer: JUNG PUMPEN GmbH - Industriestr. 4-6 - 33803 Steinhagen - Germany - www.jung-pumpen.de

We hereby declare, under our sole responsibility, that the product is in accordance with the specified Legislation.

UV 305-1(JP50709)
UV 305-1S (JP50706)
UV 310-1(JP50710)
UV 310-1S(JP50707)
UV 315-1(JP50711)
UV 315-1S(JP50708)
UV 620-1(JP47337)

Other normative documents:

EN 62233:2008/AC:2008

Authorized person for technical documentation

JUNG PUMPEN - Stefan Sirges - Industriestr. 4-6 - 33804 Steinhagen

Steinhagen, 02-11-2022



Stefan Sirges, General Manager



i.V. Pascal Kölkebeck, Sales Manager



0197

JUNG PUMPEN GmbH - Industriestr. 4-6 33803 Steinhagen, Germany
17
421.12.2210

EN 12050-2:2001; 2015; 2015
Abwasserhebeanlage für fäkalienfreies Abwasser

UV 305-1(JP48691)	UV 620-1(JP47337)
UV 305-1S(JP48693)	UV 620-1S(JP47338)
UV 305-3(JP48692)	UV 620-3(JP47339)
UV 305-3S(JP48694)	UV 620-3S(JP47340)
UV 310-1(JP48695)	UV 625-3(JP47341)
UV 310-1S(JP48697)	UV 625-3S(JP47342)
UV 310-3(JP48696)	UV 635-3(JP47343)
UV 310-3S(JP48698)	UV 635-3S(JP47344)
UV 315-1(JP48699)	
UV 315-1S(JP48701)	
UV 315-3(JP48700)	
UV 315-3S(JP48702)	

Sammeln und automatisches Heben von fäkalienfreiem Abwasser innerhalb und außerhalb von Gebäuden über die Rückstauenebene

BRANDVERHALTEN	NPD
WASSERDICHTHEIT	Bestanden
WIRKSAMKEIT (HEBEWIRKUNG)	
- Förderung von Feststoffen	Bestanden
- Rohranschlüsse	Bestanden
- Lüftung	NPD
- Mindestfließgeschwindigkeit	Bestanden
- Freier Mindestdurchgang der Anlage	Bestanden
- Mindestnutz volumen	NPD
MECHANISCHE FESTIGKEIT	
- Tragfähigkeit und strukturelle Stabilität des Sammelbehälters für die Verwendung außerhalb von Gebäuden	NPD
- Strukturelle Stabilität des Sammelbehälters für die Verwendung innerhalb von Gebäuden	NPD
GERÄUSCHPEGEL	70 dB(A)
DAUERHAFTIGKEIT	
- der Wasserdichtheit und Luftdichtheit	Bestanden
- der Hebewirkung	Bestanden
- der mechanischen Festigkeit	Bestanden
GEFÄHRLICHE SUBSTANZEN	NPD



0197

JUNG PUMPEN GmbH - Industriestr. 4-6 33803 Steinhagen, Germany
17
421.12.2210

EN 12050-2:2001; 2015
Lifting plant for faecal-free wastewater

UV305-1S GB (JP50706)
UV310-1S GB (JP50707)
UV315-1S GB (JP50708)
UV305-1 GB (JP50709)
UV310-1 GB (JP50710)
UV315-1 GB (JP50711)
UV 620-1 (JP47337)

Collecting and automatically lifting faecal-free waste water above the backflow level in buildings and sites

REACTION TO FIRE	NPD
WATERTIGHTNESS	Pass
EFFECTIVENESS (LIFTING EFFECTIVENESS)	
- Pumping of solids	Pass
- Pipe connections	Pass
- Ventilation	NPD
- Minimum flow velocity	Pass
- Minimum free passage of the plant	Pass
- Minimum useful volume	NPD
MECHANICAL RESISTANCE	
- Load bearing capacity and structural stability of collection tank for use outside buildings	NPD
- Structural stability of collection tank for use inside buildings	NPD
NOISE LEVEL	70 dB(A)
DURABILITY	
- of structural stability	Pass
- of lifting effectiveness	Pass
- of mechanical resistance	Pass
DANGEROUS SUBSTANCES	NPD



JUNG PUMPEN GmbH - Industriestr. 4-6 33803 Steinhagen, Germany
17
421.12.2210

EN 12050-2:2001; 2015
Station de relevage pour effluents exempts de matières fécales DN 32

UV 305-1(JP48691)	UV 620-1(JP47337)
UV 305-1S(JP48693)	UV 620-1S(JP47338)
UV 305-3(JP48692)	UV 620-3(JP47339)
UV 305-3S(JP48694)	UV 620-3S(JP47340)
UV 310-1(JP48695)	UV 625-3(JP47341)
UV 310-1S(JP48697)	UV 625-3S(JP47342)
UV 310-3(JP48696)	UV 635-3(JP47343)
UV 310-3S(JP48698)	UV 635-3S(JP47344)
UV 315-1(JP48699)	
UV 315-1S(JP48701)	
UV 315-3(JP48700)	
UV 315-3S(JP48702)	

Collecte et relevage des eaux usées exemptes de matières fécales à l'intérieur et à l'extérieur des bâtiments au-dessus du niveau de refoulement

RÉACTION AU FEU	NPD
ÉTANCHÉITÉ À L'EAU	Satisfaisant
EFFICACITÉ (PERFORMANCE DE RELEVAGE)	
- Refoulement de matières solides	Satisfaisant
- Raccords de tuyaux	Satisfaisant
- Aération	NPD
- Débit minimum	Satisfaisant
- Passage libre minimal de l'installation	Satisfaisant
- Volume utile minimal	NPD
RÉSISTANCE MÉCANIQUE	
- Capacité de charge et stabilité structurelle du collecteur pour une utilisation à l'extérieur des bâtiments	NPD
- Stabilité structurelle du collecteur pour une utilisation à l'intérieur des bâtiments	NPD
NIVEAU SONORE	70 dB(A)
RÉSISTANCE	
- de la stabilité structurelle	Satisfaisant
- de la performance de relevage	Satisfaisant
- de la résistance mécanique	Satisfaisant
SUBSTANCES DANGEREUSES	NPD



JUNG PUMPEN GmbH - Industriestr. 4-6 33803 Steinhagen, Germany
17
421.12.2210

EN 12050-2:2001; 2015
Afvalwaterpompinstallatie voor afvalwater zonder fecaliën DN 32

UV 305-1(JP48691)	UV 620-1(JP47337)
UV 305-1S(JP48693)	UV 620-1S(JP47338)
UV 305-3(JP48692)	UV 620-3(JP47339)
UV 305-3S(JP48694)	UV 620-3S(JP47340)
UV 310-1(JP48695)	UV 625-3(JP47341)
UV 310-1S(JP48697)	UV 625-3S(JP47342)
UV 310-3(JP48696)	UV 635-3(JP47343)
UV 310-3S(JP48698)	UV 635-3S(JP47344)
UV 315-1(JP48699)	
UV 315-1S(JP48701)	
UV 315-3(JP48700)	
UV 315-3S(JP48702)	

Verzamelen en automatisch pompen van afvalwater zonder fecaliën binnen en buiten gebouwen boven het terugstuwniveau

BRANDGEDRAG	NPD
WATERDICHTHEID	Succesvol
RENDEMENT (POMPWERKING)	
- Transport van vaste stoffen	Succesvol
- Buisaansluitingen	Succesvol
- Verlichtingsleidingen	NPD
- Minimum doorstromingssnelheid	Succesvol
- Minimum vrije doorgang van de installatie	Succesvol
- Minimum nuttig volume	NPD
MECHANISCHE VASTHEID	
- Draagkracht en structurele stabiliteit van de verzamelcontainer voor het gebruik buiten gebouwen	NPD
- Structurele stabiliteit van de verzamelcontainer voor het gebruik binnenin gebouwen	NPD
GELUIDSNIVEAU	70 dB(A)
DUURZAAMHEID	
- van de structurele stabiliteit	Succesvol
- van de pompwerking	Succesvol
- van de mechanische vastheid	Succesvol
GEVAARLIJKE STOFFEN	NPD



JUNG PUMPEN GmbH - Industriestr. 4-6 33803 Steinhagen, Germany
17
421.12.2210

EN 12050-2:2001; 2015
Stazione di sollevamento per acque di scarico prive di sostanze fecali DN 32

UV 305-1(JP48691)	UV 620-1(JP47337)
UV 305-1S(JP48693)	UV 620-1S(JP47338)
UV 305-3(JP48692)	UV 620-3(JP47339)
UV 305-3S(JP48694)	UV 620-3S(JP47340)
UV 310-1(JP48695)	UV 625-3(JP47341)
UV 310-1S(JP48697)	UV 625-3S(JP47342)
UV 310-3(JP48696)	UV 635-3(JP47343)
UV 310-3S(JP48698)	UV 635-3S(JP47344)
UV 315-1(JP48699)	
UV 315-1S(JP48701)	
UV 315-3(JP48700)	
UV 315-3S(JP48702)	

Raccolta e sollevamento automatico di acque reflue prive di sostanze fecali all'interno o all'esterno di edifici sopra il livello di ristagno

INFIAMMABILITÀ	NPD
IMPERMEABILITÀ	Superata
EFFICACIA (CAPACITÀ DI SOLLEVAMENTO)	
- Pompaggio di materiali solidi	Superata
- Collegamenti al tubo	Superata
- Ventilazione	NPD
- Velocità di scorrimento minima	Superata
- Passaggio libero minimo dell'impianto	Superata
- Volume utile minimo	NPD
RESISTENZA MECCANICA	
- Capacità di carico e stabilità strutturale del serbatoio di raccolta per l'uso al di fuori degli edifici	NPD
- Stabilità strutturale del serbatoio di raccolta per l'uso all'interno degli edifici.	NPD
SOGLIA DI RUMOROSITÀ	70 dB(A)
DUREVOLEZZA	
- della stabilità strutturale	Superata
- della capacità di sollevamento	Superata
- della resistenza meccanica	Superata
SOSTANZE PERICOLOSE	NPD



JUNG PUMPEN GmbH - Industriestr. 4-6 33803 Steinhagen, Germany
17
421.12.2210

EN 12050-2:2001; 2015
Instalacja przepompowni ścieków dla ścieków fekalnych DN 32

UV 305-1(JP48691)	UV 620-1(JP47337)
UV 305-1S(JP48693)	UV 620-1S(JP47338)
UV 305-3(JP48692)	UV 620-3(JP47339)
UV 305-3S(JP48694)	UV 620-3S(JP47340)
UV 310-1(JP48695)	UV 625-3(JP47341)
UV 310-1S(JP48697)	UV 625-3S(JP47342)
UV 310-3(JP48696)	UV 635-3(JP47343)
UV 310-3S(JP48698)	UV 635-3S(JP47344)
UV 315-1(JP48699)	
UV 315-1S(JP48701)	
UV 315-3(JP48700)	
UV 315-3S(JP48702)	

Zbieranie i automatyczne przepompowywanie ścieków fekalnych wewnątrz budynków i poza nimi powyżej poziomu cofki

WŁAŚCIWOŚCI OGNIOWE	NPD
SZCZELNOŚĆ WODNA	Pozytywnie
SPRAWNOŚĆ DZIAŁANIA (SKUTECZNOŚĆ TŁOCZENIA)	
- Tłoczenie substancji stałych	Pozytywnie
- Przyłącza rurowe	Pozytywnie
- Wentylacja	NPD
- Minimalna prędkość przepływu	Pozytywnie
- Minimalna, swobodna przepustowość instalacji	Pozytywnie
- Minimalna objętość użytkowa	NPD
WYTRZYMAŁOŚĆ MECHANICZNA	
- Nośność i stabilność konstrukcyjna zbiornika podczas stosowania poza budynkami	NPD
- Nośność i stabilność konstrukcyjna zbiornika podczas stosowania w budynkach	NPD
POZIOM HAŁASU	70 dB(A)
TRWAŁOŚĆ I WYTRZYMAŁOŚĆ	
- stabilność konstrukcyjna	Pozytywnie
- skuteczność tłoczenia	Pozytywnie
- wytrzymałość mechaniczna	Pozytywnie
SUBSTANCJE NIEBEZPIECZNE	NPD



0197

JUNG PUMPEN GmbH - Industriestr. 4-6 33803 Steinhagen, Germany
17
421.12.2210

EN 12050-2:2001; 2015
Čerpací stanice odpadních vod bez fekálií DN 32

UV 305-1(JP48691)	UV 620-1(JP47337)
UV 305-1S(JP48693)	UV 620-1S(JP47338)
UV 305-3(JP48692)	UV 620-3(JP47339)
UV 305-3S(JP48694)	UV 620-3S(JP47340)
UV 310-1(JP48695)	UV 625-3(JP47341)
UV 310-1S(JP48697)	UV 625-3S(JP47342)
UV 310-3(JP48696)	UV 635-3(JP47343)
UV 310-3S(JP48698)	UV 635-3S(JP47344)
UV 315-1(JP48699)	
UV 315-1S(JP48701)	
UV 315-3(JP48700)	
UV 315-3S(JP48702)	

Sběr a automatické čerpání odpadních vod s fekáliemi uvnitř a mimo budov nad úroveň zpětného vzduť

CHOVÁNÍ PŘI POŽÁRU	NPD
VODOTĚSNOST	Vyhovuje
ÚČINNOST (ZDVIH)	
- Doprava pevných látek	Vyhovuje
- Potrubní přípojky	Vyhovuje
- Větrání	NPD
- Minimální průtoková rychlost	Vyhovuje
- Volný minimální prostup zařízení	Vyhovuje
- Minimální užžitný objem	NPD
MECHANICKÁ PEVNOST	
- Nosnost a strukturální stabilita sběrné nádrže pro použití mimo budovy	NPD
- Strukturální stabilita sběrné nádrže pro použití uvnitř budov	NPD
HLUČNOST	70 dB(A)
STÁLOST	
- Strukturální stability	Vyhovuje
- Zdvihu	Vyhovuje
- Mechanické pevnosti	Vyhovuje
NEBEZPEČNÉ SUBSTANCE	NPD



0197

JUNG PUMPEN GmbH - Industriestr. 4-6 33803 Steinhagen, Germany
17
421.12.2210

EN 12050-2:2001; 2015
Čerpacie stanice odpadových vôd bez fekálnych splaškov DN 32

UV 305-1(JP48691)	UV 620-1(JP47337)
UV 305-1S(JP48693)	UV 620-1S(JP47338)
UV 305-3(JP48692)	UV 620-3(JP47339)
UV 305-3S(JP48694)	UV 620-3S(JP47340)
UV 310-1(JP48695)	UV 625-3(JP47341)
UV 310-1S(JP48697)	UV 625-3S(JP47342)
UV 310-3(JP48696)	UV 635-3(JP47343)
UV 310-3S(JP48698)	UV 635-3S(JP47344)
UV 315-1(JP48699)	
UV 315-1S(JP48701)	
UV 315-3(JP48700)	
UV 315-3S(JP48702)	

Zber a automatické čerpanie odpadových vôd bez fekálnych splaškov v interiéroch a exteriéroch budov prostredníctvom úrovne vzduť

REAKCIA POČAS POŽIARU	NPD
VODOTĚSNOST	v poriadku
ÚČINNOST (ÚČINOK SANIA)	
- Doprava pevných částic	v poriadku
- Potrubné přípojky	v poriadku
- Vetrání	NPD
- Minimální rychlost prietoku	v poriadku
- Volný minimální priedchod systému	v poriadku
- Minimální užžitkový objem	NPD
MECHANICKÁ PEVNOST	
- Nosnost a štruktúrna stabilita zbernej nádoby pre používanie mimo budov	NPD
- Štruktúrna stabilita zbernej nádoby pre používanie v rámci budov	NPD
HLADINA HLUKU	70 dB(A)
TRVANLIVOSŤ	
- Štruktúrnej stability	v poriadku
- Veďľajších účinkov	v poriadku
- Mechanickej pevnosti	v poriadku
NEBEZPEČNÉ LÁTKY	NPD



0197

JUNG PUMPEN GmbH - Industriestr. 4-6 33803 Steinhagen, Germany
17
421.12.2210

EN 12050-2:2001; 2015
Fekáliamentes szennyvizek átemelői DN 32

UV 305-1(JP48691)	UV 620-1(JP47337)
UV 305-1S(JP48693)	UV 620-1S(JP47338)
UV 305-3(JP48692)	UV 620-3(JP47339)
UV 305-3S(JP48694)	UV 620-3S(JP47340)
UV 310-1(JP48695)	UV 625-3(JP47341)
UV 310-1S(JP48697)	UV 625-3S(JP47342)
UV 310-3(JP48696)	UV 635-3(JP47343)
UV 310-3S(JP48698)	UV 635-3S(JP47344)
UV 315-1(JP48699)	
UV 315-1S(JP48701)	
UV 315-3(JP48700)	
UV 315-3S(JP48702)	

Fekáliamentes szennyvíz gyűjtése és emelése épületeken belül és kívül a visszatörölődési szint felett

VISELKEDÉS TŰZ ESETÉN	NPD
VÍZÁLLÓSÁG	Megfelelt
HATÉKONYSÁG (EMELŐ HATÁS)	
- Szilárd anyagok szállítása	Megfelelt
- Csőcsatlakozások	Megfelelt
- Szellőzés	NPD
- Az áramlás minimális sebessége	Megfelelt
- A berendezés szabad, minimális áteresztése	Megfelelt
- Minimális hasznos volumen	NPD
MECHANIKAI SZILÁRDSÁG	
- A gyűjtőtartály terhelhetősége és strukturális stabilitása épületeken kívüli használathoz	NPD
- A gyűjtőtartály strukturális stabilitása épületeken belüli használathoz	NPD
ZAJSZINT	70 dB(A)
TARTÓSSÁG	
- a strukturális stabilitás tartóssága	Megfelelt
- az emelőhatás tartóssága	Megfelelt
- a mechanikai szilárdság tartóssága	Megfelelt
VESZÉLYES ANYAGOK	NPD

Technische Daten • Technical data • Caractéristiques techniques • Technische gegevens • Dati tecnici • Dane techniczne • Technické údaje • Műszaki adatok

		UV 305-1 UV 305-1 S	UV 310-1 UV 310-1 S	UV 315-1 UV 315-1 S	UV 305-3 UV 305-3 S	UV 310-3 UV 310-3 S	UV 315-3 UV 315-3 S
	[kg]	17,3	19,2	19,2	17,7	19,2	19,2
		17,8	19,7	19,7	18,2	19,7	19,7
	DN	1 1/2 "	1 1/2 "	1 1/2 "	1 1/2 "	1 1/2 "	1 1/2 "
	[mm]	10	10	10	10	10	10
P1	[W]	1150	1300	1830	1150	1350	1850
P2	[W]	880	1000	1360	840	1080	1450
U	[V]	1/PE ~230	1/PE ~230	1/PE ~230	3/PE ~400	3/PE ~400	3/PE ~400
f	[Hz]	50	50	50	50	50	50
I	[A]	5,3	5,8	8,2	2,6	3,0	3,6

Leistungen • Performance • Puissances • Capaciteit • Prestazioni • Wydajności i moce • Výkony • Výchony • Teljesítmény

H [m]	1	3	5	7	9	11	13
							Q [m³/h]
UV 305-1	21	17,5	14	7			
UV 310-1	24,5	21	17	13	6		
UV 315-1	28	25	22	19	14,5	10	2
UV 305-3	22	18,5	14	8,5			
UV 310-3	24,5	21,5	17,5	13,5	6		
UV 315-3	29	25,5	23	19	15	10	3

UV 305-1 - UV 315-1

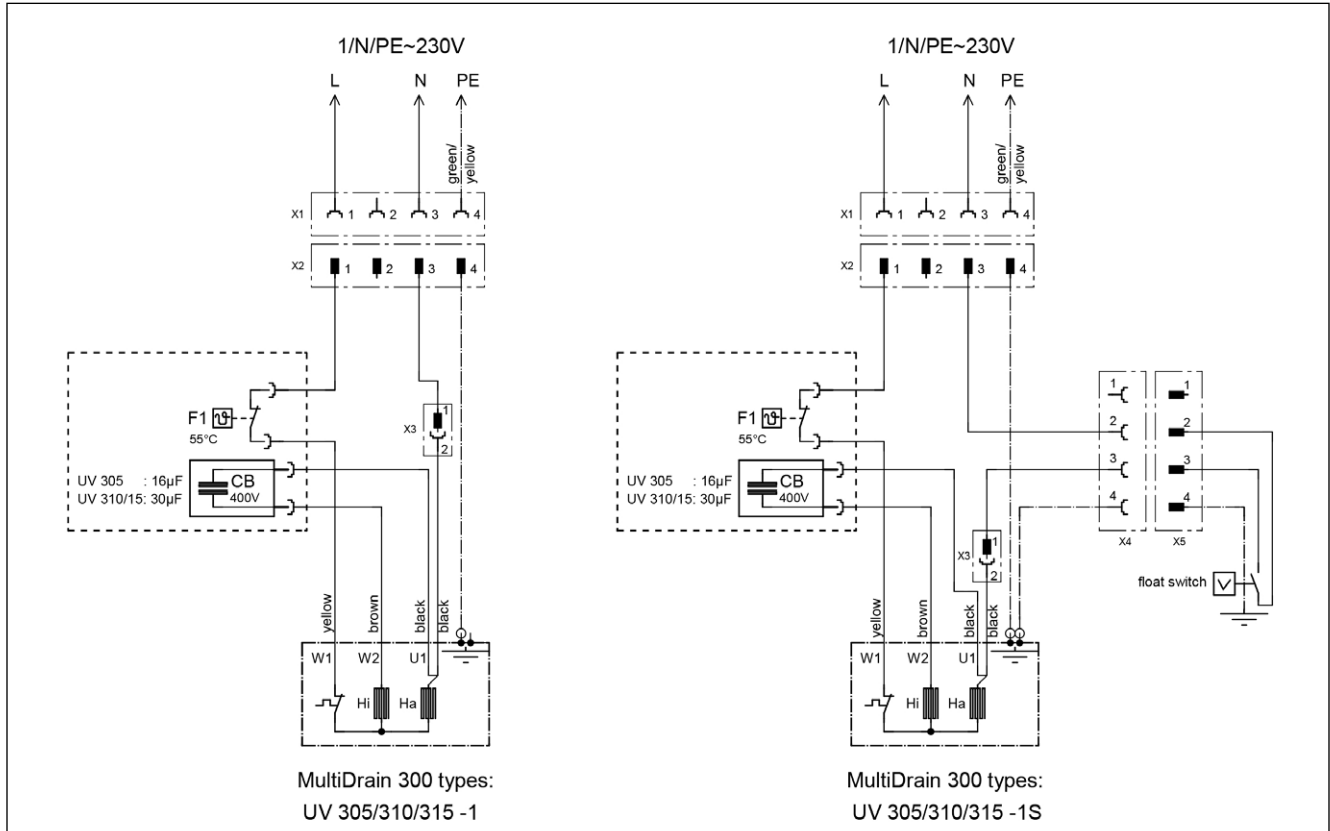

UV 305-3 - UV 315-3

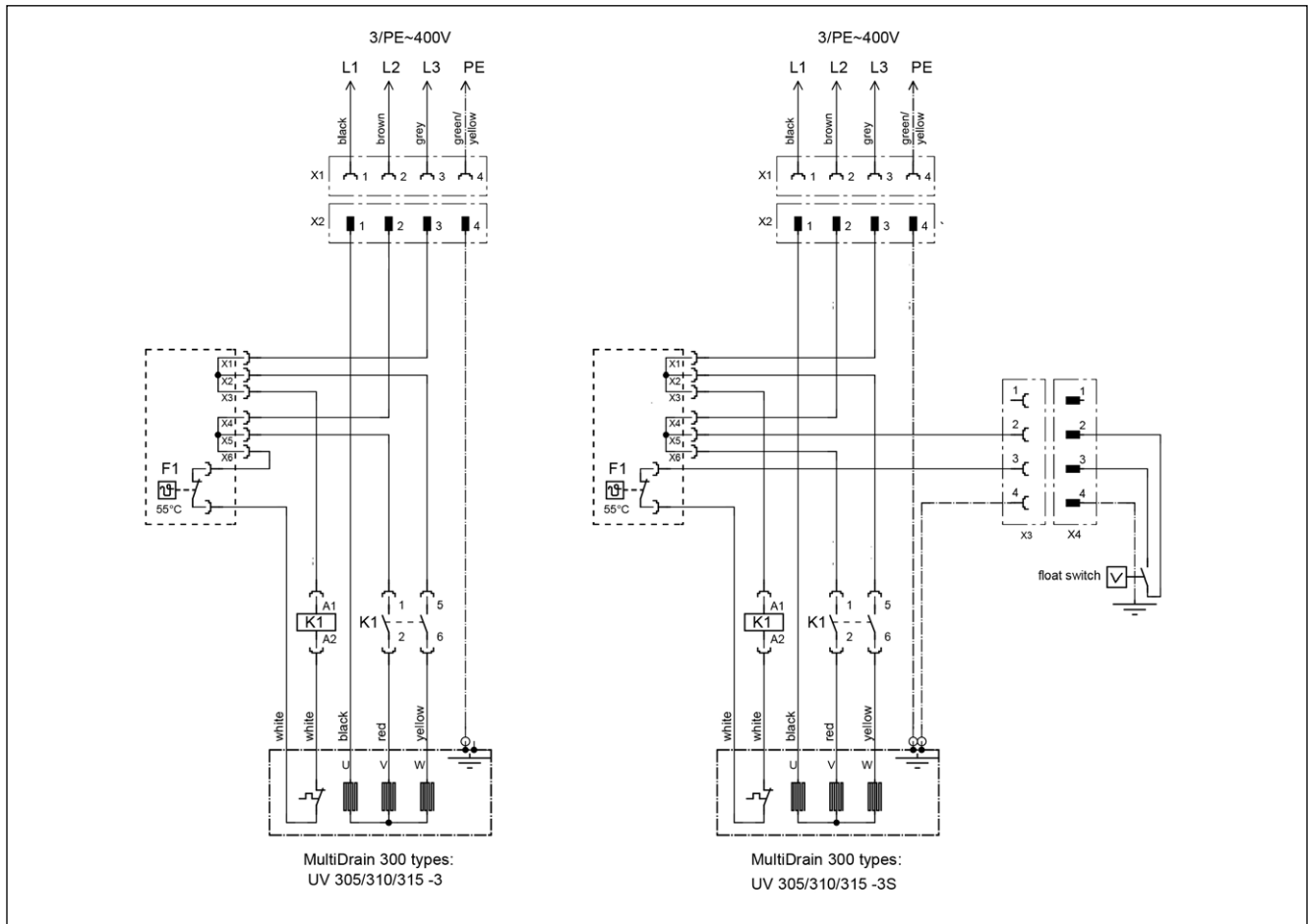

MULTIDRAIN UV 300

Ersatzteile - Spare parts - Pièces de rechange - Reserveonderdelen - Parti di ricambio - Reservedele - Reservdelar
 Varaosat - Części zamienne - Náhradní díly - Alkatrészek - Piese de schimb - Запасные части - 备件

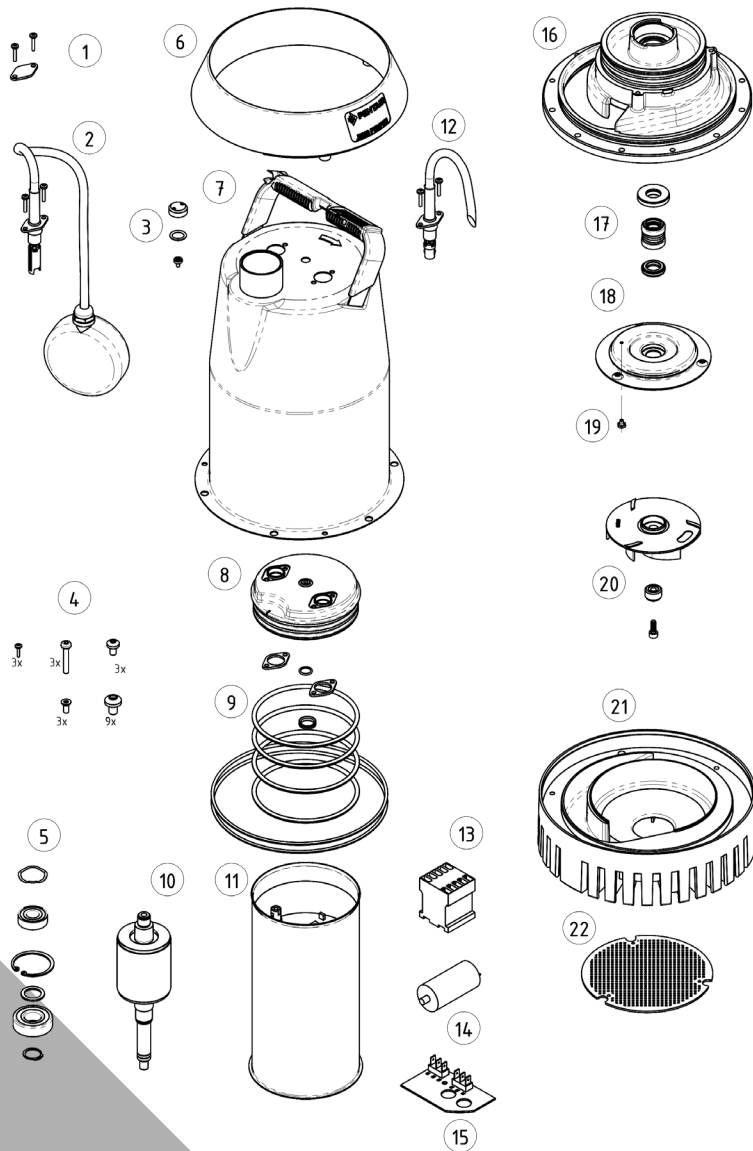

①	Blindflansch	Blind flange	JP48921
②	KT-Schalter	KT-switch	JP48881
③	Verschluss UV300	Plug UV300	JP48882
④	Schraubensatz	Screw set	JP49249
⑤	Lagersatz	Bearing set	JP48893
⑥	Abdeckung	Cover	JP49252
⑦	Doppelmantel	Double jacket	JP49253
⑧	Deckel	Plug	
	1 Loch	1 hole	JP48891
	2 Loch	2 hole	JP48892
⑨	Dichtungssatz	Seal set	JP48898
⑩	Rotorwelle	Rotor shaft	
	UV 305		JP49250
	UV 310, 315		JP49251
⑪	Stator + Gehäuse	Stator + Housing	
	UV 305-1		JP49254
	UV 310-1, UV 315-1		JP49255
	UV 305-3		JP49256
	UV 310-3, UV 315-3		JP49257
⑫	Leitung	Cable	
	230 V, UV 3xx-1,		JP49258
	400 V, UV 3xx-3		JP48884
	400 V, UV 3xx-3S		JP49259
⑬	Schalterschütz	Contacteur	JP48880
⑭	Kondensator	Capacitor	
	UV 305		JP49266
	UV 310, UV 315		JP49267
⑮	Platine	PCB	
	UV 305-1		JP50264
	UV 310-1, UV 315-1		JP50265
	UV 3xx-3		JP48896
⑯	Lagerflansch	Bearing flange	JP49260
⑰	Gleitringdicht.satz	Mech. seal set	JP48902
⑱	Dichtungsdeckel	Seal cover	JP48903
⑲	Ölschraube	Oil screw	JP48904
⑳	LaufRad	Impeller	
	UV 305		JP49261
	UV 310		JP49262
	UV 315		JP49263
㉑	Siebfuß	Strainer base	JP49264
㉒	Sieb UV 300		JP49265



Pump House
Unit 12
Bilton Road Industrial Estate
Erith, Kent, DA8 2AN

 01322 357 080

 pts-jung.co.uk

 service@pts-jung.co.uk

 sales@pts-jung.co.uk