



**PUMP TECHNICAL
SERVICES LIMITED**



THE SUBMERSIBLE PUMP SPECIALISTS

MANUFACTURING | SALES | PROJECT DESIGN | INSTALLATION | MAINTENANCE AND REPAIRS

MULTISTREAM

55/2 B2	75/2 B5	100/2 B5	55/2 B2 EX	75/2 B5 EX	100/2 B5 EX
55/4 B6	75/4 B6	100/4 C2	55/4 B6 EX	75/4 B6 EX	100/4 C2 EX
55/4 C2	75/4 C2	100/4 C5	55/4 C2 EX	75/4 C2 EX	100/4 C5 EX
55/4 C5	75/4 C5		55/4 C5 EX	75/4 C5 EX	
35/46 B6	55/26 C2	55/46 B6	UC 55/2 B2 UC 75/4 B6	UC 55/4 C5 UC 75/4 C5	UC 75/2 B5 UC 100/2 B5

EN Instruction Manual



 service@pts-jung.co.uk

 sales@pts-jung.co.uk

Pump House
Unit 12
Bilton Road Industrial Estate
Erith, Kent, DA8 2AN

 01322 357 080

 pts-jung.co.uk

You have purchased a product made by Pentair Jung Pumpen and with it, therefore, also excellent quality and service. Secure this service by carrying out the installation works in accordance with the instructions, so that our product can perform its task to your complete satisfaction. Please remember that damage caused by incorrect installation or handling will adversely affect the guarantee.

This appliance can be used by children aged 8 years or over and by persons with limited physical, sensory or intellectual capabilities, or with limited experience and knowledge, provided that they are supervised or have been instructed in the safe use of the appliance and are aware of the dangers involved. Children must not be allowed to play with the appliance. Cleaning and user maintenance must not be carried out by children unless they are supervised.

Damage prevention in case of failure

Like any other electrical device, this product may fail due to a lack of mains voltage or a technical defect.

If damage (including consequential damage) can occur as a result of product failure, the following precautions can be taken at your discretion:

- Installation of a water level dependent (under circumstances, mains-independent) alarm system, so that the alarm can be heard before damage occurs.
- Inspection of the collecting tank/chamber for tightness up to the top edge before – or at the latest, during – installation or operation of the product.
- Installation of backflow protection for drainage units that can be damaged by wastewater leakage upon product failure.
- Installation of a further product that can compensate in case of failure of the other product (e.g. duplex unit).
- Installation of an emergency power generator.

As these precautions serve to prevent or minimise consequential damage upon product failure, they are to be strictly observed as the manufacturer's guideline – in line with the standard DIN EN specifications as state of the art – when using the product (Higher Regional Court Frankfurt/Main, Ref.: 2 U 205/11, 06/15/2012).

SAFETY INSTRUCTIONS

This instruction manual contains essential information that must be observed during installation, operation and servicing. It is therefore important that the installer and the responsible technician/operator read this instruction manual before the equipment is installed and put into operation. The manual must always be available at the location where the pump or the plant is installed.

Failure to observe the safety instructions can lead to the loss of all indemnity.

In this instruction manual, safety information is distinctly labelled with particular symbols. Disregarding this information can be dangerous.



General danger to people



Warning of electrical voltage

NOTICE! Danger to equipment and operation

Qualification and training of personnel

All personnel involved with the operation, servicing, inspection and installation of the equipment must be suitably qualified for this work and must have studied the instruction manual in depth to ensure that they are sufficiently conversant with its contents. The supervision, competence and areas of responsibility of the personnel must be precisely regulated by the operator. If the personnel do not have the necessary skills, they must be instructed and trained accordingly.

Safety-conscious working

The safety instructions in this instruction manual, the existing national regulations regarding accident prevention, and any internal working, operating and safety regulations must be adhered to.

Safety instructions for the operator/user

All legal regulations, local directives and safety regulations must be adhered to.

The possibility of danger due to electrical energy must be prevented.

Leakages of dangerous (e.g. explosive, toxic, hot) substances must be discharged such that no danger to people or the environment occurs. Legal regulations must be observed.

Safety instructions for installation, inspection and maintenance works

As a basic principle, works may only be carried out to the equipment when it is shut down. Pumps or plant that convey harmful substances must be decontaminated.

All safety and protection components must be re-fitted and/or made operational immediately after the works have been completed. Their effectiveness must be checked before restarting, taking into account the current regulations and stipulations.

Unauthorised modifications, manufacture of spare parts

The equipment may only be modified or altered in agreement with the manufacturer. The use of original spare parts and accessories approved by the manufacturer is important for safety reasons. The use of other parts can result in liability for consequential damage being rescinded.

Unauthorised operating methods

The operational safety of the supplied equipment is only guaranteed if the equipment is used for its intended purpose. The limiting values given in the "Technical Data" section may not be exceeded under any circumstances.

Instructions regarding accident prevention

Before commencing servicing or maintenance works, cordon off the working area and check that the lifting gear is in perfect condition.

Never work alone. Always wear a hard hat, safety glasses and safety shoes and, if necessary, a suitable safety belt.

Before carrying out welding works or using electrical devices, check to ensure there is no danger of explosion.

People working in wastewater systems must be vaccinated against the pathogens that may be found there. For the sake of your health, be sure to pay meticulous attention to cleanliness wherever you are working.

Make sure that there are no toxic gases in the working area.

Observe the health and safety at work regulations and make sure that a first-aid kit is to hand.

In some cases, the pump and the pumping medium may be hot and could cause burns.

For installations in areas subject to explosion hazards, special regulations apply!

AREAS OF APPLICATION

Submersible pumps in the MultiStream range are suitable for pumping wastewater in municipal and industrial pumping stations, and in rainwater retention tanks.

MultiStream pumps are favoured for use with:

- wastewater containing fibres
- wastewater containing solids (without stones)
- mixed wastewater
- untreated water
- raw sludge
- surface water and rainwater

The submersible pumps are supplied without explosion protection or with explosion protection.

When using the pumps, the relevant national laws, regulations and stipulations must be adhered to, for example:

- Installation of low-voltage systems (e.g., VDE 0100 in Germany)
- Safety and working materials (e.g., BetrSichV and BGR 500 in Germany)
- Safety in wastewater systems (e.g., GUV-V C5, GUV-R 104 and GUV-R 126 in Germany)
- Electrical systems and operating resources (e.g., GUV-V A3 in Germany)
- Explosion protection EN 60079-0, EN 60079-1 and EN 1127-1

For non-standard utilisation conditions in areas subject to explosion hazards, please ask the local authority responsible.

In Germany, this would be, for example, the Trade Supervisory Centre (Gewerbeaufsicht), the Technical Inspection Agency (TÜV), the building authority (Bauamt) or professional organisation (Berufsgenossenschaft).

The installation and operation of this equipment is regulated by the ordinance concerning the protection of health and safety in the provision of work equipment and its use at work, concerning safety when operating installations subject to monitoring, and concerning the organisation of industrial health and safety at work, (Betriebssicherheitsverordnung), Article 1.

Where no explosion protection is stipulated for the pumping of foul wastewater at the installation location, pumps without explosion protection may also be used.

Modes of operation

with the pumped medium at a temperature of 40°C:

Motor submersed: continuous operation S1

Motor emerged: short duration operation S2; see "Technical Data"

Motor emerged: intermittent operation S3; see "Technical Data"

The submersible pump is frost-resistant down to -20°C when stored in dry conditions. When installed, however, it must not be allowed to freeze in the water.

Transport

The pump must never be lifted by the power supply cable! The pump should only be lowered by using a chain.

ELECTRICAL CONNECTION

Circuitry

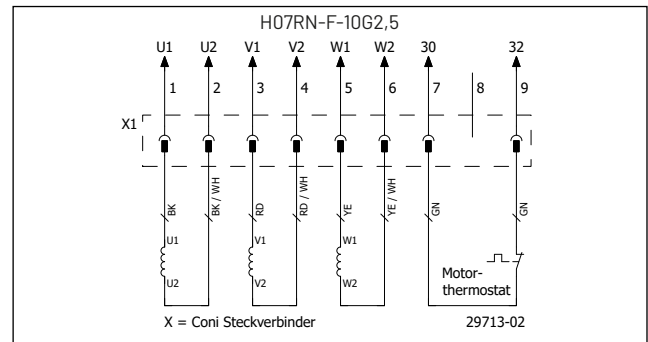

Alterations to the circuitry are to be made using crimp connectors (X2) between the conical plug connection (X1) and the built-in motor. The new crimp connection must be professionally made.

By using our controls, you can be sure that the requirements of the EU type-testing certificate are met.

NOTICE! Only qualified electricians may carry out electrical works to the pump or the controls.

The standards applicable in each case (e.g. EN), the country-specific regulations (e.g. VDE in Germany), and the regulations of the local supply network operator must be observed.

NOTICE! Never lay the end of cables in water! Penetrating water may cause malfunctions.

Only slow-blow fuses or automatic fuses with C or D characteristics are to be used as pre-fuses for the pump. Necessary fuse protection for star-delta start 16 A for pumps 55..., 20 A for pumps 75... and 25 A for pumps 100...

The pump must be protected via an overload trip. Setting for direct on-line start = nominal current, and for star-delta start = nominal current x 0.58.

If the protective device has been triggered, the cause of the malfunction must be eliminated before switching on again.

Coil thermostats

NOTICE! In addition to the overload trip or protective switch of the motor, the thermostats integrated in the motor winding must also be connected. The thermostats are suitable for 250 V / 1.2 A (cos phi = 0.6) and are labelled 30 and 32 for connection purposes.

Thermostat connection without explosion protection

The thermostats are to be connected in such a way that the motor is switched off via the control circuit when the response temperature is reached. The motor is switched on again automatically after the winding has cooled down.

Thermostat connection with explosion protection

The thermostats are to be connected in such a way that the motor is switched off via the control circuit when the response temperature is reached. It must not be possible for the motor to switch on again automatically after the winding has cooled down.

⚠ WARNING!

After an automatic cut-out via the temperature limiters, the cause of the malfunction must first be eliminated. Only then may the motor be switched on again manually.

The restart interlock must be "non-resetting on power failure", i.e. the lock must be in place to prevent restarting even after a power cut (in Europe: Directive 2014/34/EU, Appendix II 1.5, EN 60079-17 Table1, B8).

Operation with frequency converter

Frequency converters may only be used for controlling the frequency of special models of three-phase pumps. For hydraulic reasons we do not recommend operation below 30 Hz.

NOTICE! For physical reasons, pumps may not be operated at a higher frequency than that shown on the type plate. If the frequency increases beyond the value on the type plate, the power input increases and the motor is then overloaded.

For special models of three-phase pumps that are designed for frequency converter operation, the motor type shown on the type plate is labelled with an additional "K" (e.g. D90-2/75 CK). These pumps also have a sticker on the end of the cable that indicates their suitability for use with a frequency converter.

These motors are fitted with PTC thermistors as winding protectors. Voltages of more than 2.5 V may not be connected to the winding protection terminals 40 and 41! For explosion protected pumps, a type-tested tripping unit that complies with the EU type-testing requirements is also necessary.

Rotational direction

The rotational direction must be checked before installation! If the rotational direction is correct, the start-up jolt should be in the opposite direction to the rotational direction arrow on the motor housing. The wrong rotational direction is also indicated if the pump performs inadequately when installed, or if loud noises can be heard during operation. If the rotational direction is wrong, 2 phases of the supply cable must be swapped over.

⚠ CAUTION!

The start-up jolt can be very forceful.

Potential equalisation

To comply with EN 60079-14 and EN 1127-1, an additional equipotential bonding must be installed for facilities with protective earth conductors in TN/TT networks in areas subject to explosion hazards. In Germany, for example, the design must be in accordance with VDE 0100, Part 540 (Association of German Electrical Engineers).

No additional potential equalisation is required on site for JUNG PUMPEN concrete or plastic chambers in explosion zones 1 and 2 (statement made by TÜV Nord (Technical Inspection Agency) in March 2008).

Exception: if conductive parts, such as cable protection sleeves made of corrugated pipe or a pressure pipe made of metal, are connected to the chamber from the outside. In this case, an electrically conductive connection must be made between the conductive parts and the housing of the pump(s). For corrosion protection reasons, the connection should be made using stainless steel.

Explosion protected pumps have a special connection point at the cable entry point.

INSTALLATION

ATTENTION! Before the pump can be installed, the 4 plastic packaging feet must be unscrewed from the bottom of the pump housing and removed.

The pump must be installed as shown in the examples. For installations in accordance with EN 12056-4, the pressure pipe must be laid in a loop above the local back pressure level and protected with a back pressure prevention valve.

Example installation with guide rail system

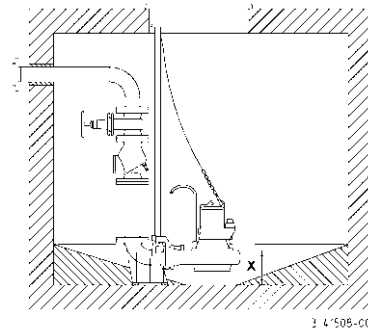

Assembly: Fix the coupling base firmly to the floor of the collection chamber using plugs and then mount the guide rails. Next, install the pressure pipe including the necessary fittings, such as the non-return valve and shut-off valves.

Finally, fit the pump with the screwed-on coupling catch on to the guide rails and lower it into place using a chain fixed to the shackle.

A fixing facility for lifting gear should be provided above the chamber opening at a sufficient height.

Level monitoring can be carried out using various systems. Their specific characteristics and requirements can be found in the relevant operating manuals.

⚠ WARNING!

In accordance with the explosion protection laws and regulations, JUNG Ex-pumps should never be allowed to run dry or to operate in "snore" mode.

The pump must switch off when the water level sinks to the upper edge of the pump housing (x in the illustration), at the very latest. This shut-down must be implemented via a separate switching circuit. Dry running for servicing or inspection purposes may only take place outside the potentially explosive area.

A correspondingly larger diameter pipe should be used for longer pressure pipelines to avoid pipe friction losses.

Rising pressure pipes must be protected from frost! A chamber cover must be selected that is suitable for the intended use and has the required load-bearing capacity.

If necessary, the pump housing can be ventilated by unscrewing the "Luft" sealing screw. A flushing pipe, available as an accessory, can be installed to minimise deposits and the formation of floating layers in the chamber.

If the pump is malfunctioning, part of the contents of the oil reservoir could escape into the pumping medium.

Not Ex-pumps. If a hose is used as a pressure line, care must be taken to ensure that for every pumping operation the hose is completely empty before the pump is submerged. Any residual liquid would obstruct the ventilation of the pump housing and therefore also hinder the pumping operation.

This situation can also occur if the pump runs dry, pumps down to a lower lever than that shown in the installation drawing, or runs in "snore" mode during the daily test run.

In these cases, the pump housing must be ventilated by unscrewing the "LUFT" sealing screw.

SERVICING

Maintenance and inspection of this product must be carried out in accordance with EN 12056-4 and EN 60079-14.

To ensure continued reliability of service, we recommend that you take out a service contract.

WARNING!

Before carrying out any works: disconnect the pump and the controls from the mains and take steps to ensure that it cannot be energized again.

WARNING!

Check the mains cable for signs of mechanical and chemical damage. Damaged or kinked cables must be replaced by the manufacturer.

NOTICE! When using a chain to lift the pump, please observe the relevant national regulations regarding accident prevention. Lifting gear must be checked regularly by an expert in accordance with the legal regulations.

NOTICE! Motors in the Ex-range conform to the "flameproof enclosures" ignition protection category. Maintenance works that affect the explosion protection may only be carried out by authorised specialists or by the manufacturer. When carrying out repairs, all areas next to flameproof gaps must be checked for damages and, if necessary, replaced by genuine parts.

Oil check

The drain plug is labelled "OEL". In order to check the mechanical seal, the oil, including any residue, must be drained from the oil reservoir and collected in a clean measuring container.

- If the oil is contaminated with water (milky), an oil change must be carried out. Check again after a further 300 operating hours, but at the very latest after 6 months!
- However, if the oil is contaminated with both water and pollutants, then not only the oil must be replaced, but the mechanical seal as well.

For monitoring the oil reservoir, it is also possible to retrofit the electrode of our "DKG" or "DKG-Ex" seal leak control device in place of the "DKG" sealing screw.

Changing the oil

To ensure operational liability, the first oil change should be carried out after 300 operating hours, with further oil changes carried out after every 1000 operating hours.

If the number of operating hours is very low, an oil change should still be carried out at least once a year.

If wastewater with strongly abrasive constituents is being pumped, the oil changes should be carried out at correspondingly shorter intervals.

Use HLP hydraulic mineral oil, viscosity class 22 to 46, e.g. Mobil DTE 22, DTE 24, DTE 25, to replace the oil in the oil reservoir.

The quantity of oil required is 1300 cm³.

NOTICE! The oil reservoir may only be filled with the specified quantity of oil. Overfilling will result in the pump being rendered inoperable.

Cleaning

To clean the impeller and the spiral housing, simply remove the 4 hexagonal screws and lift the motor unit off the spiral housing.

CAUTION!

Worn impellers can have sharp edges.

NOTICE! If the wrong screws are unscrewed, the oil will run out of the oil reservoir.

Tightening torque M_A for A2 screw materials

- for M 6 $M_A = 8 \text{ Nm}$
- for M 8 $M_A = 20 \text{ Nm}$
- for M 10 $M_A = 40 \text{ Nm}$
- for M 12 $M_A = 70 \text{ Nm}$
- for M 16 $M_A = 160 \text{ Nm}$

Checking the pump unit

The housing screws for the pump, and the connecting and fixing screws of the installation must be checked to ensure they are fixed securely. They should be tightened if necessary.

If the pump performance decreases, or if increasingly loud noises can be heard during operation, the gap dimension between the impeller face and the wear plate must be checked for wear by an expert and replaced if necessary. Nominal dimension: 0.5 - 0.8 mm.

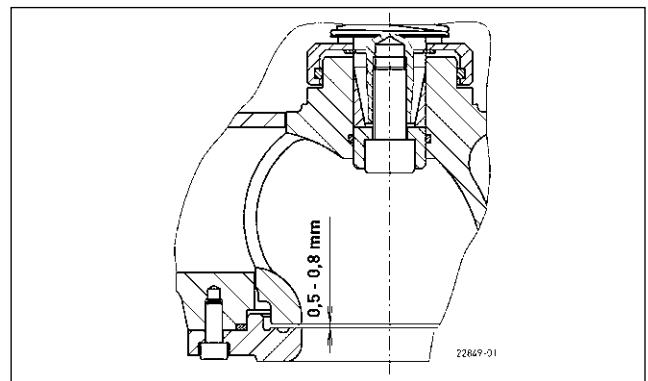

Adjust the impeller gap

1. Block the impeller.
2. Loosen the central impeller screw located in the impeller hub.
3. Loosen the impeller by knocking it gently with a hammer.
4. Tighten the impeller screw until it is "hand tight".
5. Adjust the impeller gap by pulling the impeller down to the nominal dimension 0.5 - 0.8 mm.
6. Block the impeller again and tighten the impeller screw to 160 Nm.

The maximum adjustment possible is 3 mm

Replace the wear plate

1. Loosen the four cylinder head screws on the wear plate on the lower pump case.
2. Take out the old wear plate with the seal.
3. Clean the wear plate seat and insert the new wear plate with

a new seal.

4. Tighten the four cylinder head screws again.
5. After this, readjust the impeller gap again.

Replacing the impeller

CAUTION!

Worn impellers can have sharp edges.

1. Remove the 4 hexagonal screws and lift the motor unit off the spiral housing.
2. Block the impeller.
3. Loosen the central impeller screw located in the impeller hub.
4. Loosen the impeller by knocking it gently with a hammer and then slide it off the shaft.
5. Clean all the parts of the impeller mounting.
6. Grease the shaft cover on the inside. **Notice!** Do not use grease containing graphite, such as "Molykote".
7. Fix all the parts of the impeller mounting in place and tighten the impeller screw until it is "hand tight".
8. Slide the new impeller over the preassembled impeller mounting onto the shaft.
9. Mount the motor unit on the spiral housing; the cable entry point is opposite the discharge branch.
10. Set the gap dimension to 0.5 - 0.8 mm and then tighten the impeller screw to 160 Nm.

WHAT TO DO IN THE EVENT OF ANY PROBLEMS

Pump does not work

- Check mains current (do not use a pin gauge)
- Fuse faulty = may be too weak (please refer to Electrical Connection)
- Mains supply cable damaged = repair to be carried out by manufacturer only

Pump runs but does not pump

- Empty pressure pipe or hose to allow the non-return valve to open and let the air escape from the pump housing.
- Ventilate the pump housing by unscrewing the "LUFT" (air) sealing screw.

The impeller is blocked

- Solids and fibrous matter have become lodged in the pump housing (please refer to Maintenance)

Decreased pumping performance

- The impeller is blocked (please refer to maintenance)
- Rotor gap too large = adjust (please refer to maintenance)
- The impeller or the wear plate is worn out = replace it (please refer to maintenance)
- Wrong direction of rotation = change 2 phases of the power supply

 0197	
JUNG PUMPEN GmbH - Industriestr. 4-6 - 33803 Steinhagen, Germany 13 412.17.2209	
EN 12050-1:2001; 2015 Fäkalienhebeanlage	
55/2 B2 (JP09663/2) 55/4 B6 (JP00486/3) 55/4 C2 (JP00487/3) 55/4 C5 (JP09901/2) 75/2 B5 (JP00485/3) 75/4 B6 (JP00489/3) 75/4 C2 (JP00490/3) 75/4 C5 (JP09904/2) 100/2 B5 (JP09740/1) 100/4 C2 (JP09678/1) 100/4 C5 (JP09275/1)	55/2 B2, EX (JP09664/2) 55/4 B6, EX (JP09666/2) 55/4 C2, EX (JP09668/2) 55/4 C5, EX (JP09902/2) 75/2 B5, EX (JP09665/2) 75/4 B6, EX (JP09667/2) 75/4 C2, EX (JP09669/2) 75/4 C5, EX (JP09905/2) 100/2 B5, EX (JP09741/1) 100/4 C2, EX (JP09679/1) 100/4 C5, EX (JP09276/1)
Sammeln und automatisches Heben von fäkalienfreiem und fäkalienhaltigem Abwasser über die Rückstauenebene	

BRANDVERHALTEN	NPD
WASSERDICHTHEIT	Bestanden
WIRKSAMKEIT (HEBEWIRKUNG)	
- Förderung von Feststoffen	Bestanden
- Rohranschlüsse	Bestanden
- Mindestmaße von Lüftungsleitungen	NPD
- Mindestfließgeschwindigkeit	Bestanden
- Freier Mindestdurchgang der Anlage	Bestanden
- Mindestnutzvolume	NPD
MECHANISCHE FESTIGKEIT	
- Tragfähigkeit und strukturelle Stabilität des Sammelbehälters für die Verwendung außerhalb von Gebäuden	NPD
- Strukturelle Stabilität des Sammelbehälters für die Verwendung innerhalb von Gebäuden	NPD
GERÄUSCHPEGEL	70 dB(A)
DAUERHAFTIGKEIT	
- der Wasserdichtheit und Luftdichtheit	Bestanden
- der Hebewirkung	Bestanden
- der mechanischen Festigkeit	Bestanden
GEFÄHRLICHE SUBSTANZEN	NPD

 0197	
JUNG PUMPEN GmbH - Industriestr. 4-6 - 33803 Steinhagen, Germany 13 411.17.2209	
EN 12050-1:2001; 2015 Lifting plant for wastewater containing faecal matter	
55/2 B2 (JP09663/2) 55/4 B6 (JP00486/3) 55/4 C2 (JP00487/3) 55/4 C5 (JP09901/2) 75/2 B5 (JP00485/3) 75/4 B6 (JP00489/3) 75/4 C2 (JP00490/3) 75/4 C5 (JP09904/2) 100/2 B5 (JP09740/1) 100/4 C2 (JP09678/1) 100/4 C5 (JP09275/1)	55/2 B2 (JP09663/2) 55/4 B6 (JP00486/3) 55/4 C2 (JP00487/3) 55/4 C5 (JP09901/2) 75/2 B5 (JP00485/3) 75/4 B6 (JP00489/3) 75/4 C2 (JP00490/3) 75/4 C5 (JP09904/2) 100/2 B5 (JP09740/1) 100/4 C2 (JP09678/1) 100/4 C5 (JP09275/1)
Collection and automatic lifting of wastewater without sewage and wastewater containing faecal matters above the backflow level	

REACTION TO FIRE	NPD
WATERTIGHTNESS	Pass
EFFECTIVENESS (LIFTING EFFECTIVENESS)	
- Pumping of solids	Pass
- Pipe connections	Pass
- Minimum dimensions of ventilating pipes system	NPD
- Minimum flow velocity	Pass
- Minimum free passage of the plant	Pass
- Minimum useful volume	NPD
MECHANICAL RESISTANCE	
- Load bearing capacity and structural stability of collection tank for use outside buildings	NPD
- Structural stability of collection tank for use inside buildings	NPD
NOISE LEVEL	70 dB(A)
DURABILITY	
- of structural stability	Pass
- of lifting effectiveness	Pass
- of mechanical resistance	Pass
DANGEROUS SUBSTANCES	NPD

EU-Konformitätserklärung
EU-Prohlášení o shodě
EU-Overensstemmelseserklæring
EU-Declaration of Conformity
EU-Declarazione di conformità
EU-Vaatimustenmukaisuusvakuutus
EU-Declaración de Conformidad
EU-Megfelelőseégi nyilatkozat
EU-Dichiarazione di conformità
EU-Vyhlašení o zhode
EU-Försäkrän om överensstämmelse

EU-Konformitätserklärung
EU-Prohlášení o shodě
EU-Overensstemmelseserklæring
EU-Declaration of Conformity
EU-Declarazione di conformità
EU-Vaatimustenmukaisuusvakuutus
EU-Declaración de Conformidad
EU-Megfelelőseégi nyilatkozat
EU-Dichiarazione di conformità
EU-Vyhlašení o zhode
EU-Försäkrän om överensstämmelse

DE - Richtlinien - Harmonisierte Normen
 CS - Směrnice - Harmonizované normy
 DA - Direktiv - Harmoniseret standard
 EN - Directives - Harmonised standards
 FI - Direktiivi - Yhdenmukaistetun standardi
 FR - Directives - Normes harmonisées
 HU - Irányelve - Harmonizált szabványok
 IT - Direttive - Norme armonizzate
 NL - Richtlijnen - Geharmoniseerde normen
 PL - Dyrektywy - Normy zharmonizowane
 PT - Directiva - Normas harmonizadas
 RO - Directivă - Norme coroborate
 SK - Smernice - Harmonizované normy
 SV - Direktiv - Harmoniserade normer

• 2006/42/EG (MD) EN 809:1998/AC:2010, EN ISO 12100:2010
• 2011/65/EU (RoHS)
• 2014/30/EU (EMC) EN 60034-1: 2010/AC: 2010, EN 61000-3-2:2014, EN 61000-3-3:2013
• 2014/54/EU (ATEX) EN 60079-0:2018, EN 60079-1:2014

DE - Richtlinien - Harmonisierte Normen
 CS - Směrnice - Harmonizované normy
 DA - Direktiv - Harmoniseret standard
 EN - Directives - Harmonised standards
 FI - Direktiivi - Yhdenmukaistetun standardi
 FR - Directives - Normes harmonisées
 HU - Irányelve - Harmonizált szabványok
 IT - Direttive - Norme armonizzate
 NL - Richtlijnen - Geharmoniseerde normen
 PL - Dyrektywy - Normy zharmonizowane
 PT - Directiva - Normas harmonizadas
 RO - Directivă - Norme coroborate
 SK - Smernice - Harmonizované normy
 SV - Direktiv - Harmoniserade normer

• 2006/42/EG (MD) EN 809:1998/AC:2010, EN ISO 12100:2010
• 2011/65/EU (RoHS)
• 2014/30/EU (EMC) EN 60034-1: 2010/AC: 2010, EN 61000-3-2:2014, EN 61000-3-3:2013
• 2014/54/EU (ATEX) EN 60079-0:2018, EN 60079-1:2014

JUNG PUMPEN GmbH - Industriest. 4-6 - 33803 Steinhagen - Germany - www.jung-pumpen.de
 DE - Wir erklären in alleiniger Verantwortung, dass das Produkt den aufgeführten Richtlinien entspricht.
 CS - Prohlášíme na svou výlučnou odpovědnost, že výrobek odpovídá jmenovaným směrnici.
 DA - Vi erklærer under ansvar at produktet i overensstemmelse med de retningssøjler.
 EN - We hereby declare, under our sole responsibility, that the product is in accordance with the specified Directives.
 FI - Vakuutamme omalla vastuullamme, että tuote täyttää ohjeita.
 FR - Nous déclarons sous notre propre responsabilité que le produit répond aux directives.
 HU - Kizárólagos felelősségünk tudatában kijelentjük, hogy ez a termék megfelel az Európai Unió fennvezetett irányelveinek.
 IT - Noi dichiariamo sotto la nostra esclusiva responsabilità che il prodotto è conforme alle direttive citate.
 NL - Wij verklaren geheel onder eigen verantwoordelijkheid dat het product voldoet aan de gestelde richtlijnen.
 PL - Z pełną odpowiedzialnością oświadczamy, że produkt odpowiada postanowieniom wymienionych dyrektyw.
 PT - Declaramos, sob nossa exclusiva responsabilidade, que o produto está em conformidade com as Diretivas especificadas.
 RO - Declaram pe proprie răspundere că produsul corespunde normelor prevăzute de directivele mai sus menționate.
 SK - Na výlučnú zodpovednosť vyhlasujeme, že výrobok spĺňa požiadavky uvedených smerníc.
 SV - Vi försäkrar att produkten på vårt ansvar är utförd enligt gällande riktlinjer.

JUNG PUMPEN GmbH - Industriest. 4-6 - 33803 Steinhagen - Germany - www.jung-pumpen.de
 DE - Wir erklären in alleiniger Verantwortung, dass das Produkt den aufgeführten Richtlinien entspricht.
 CS - Prohlášíme na svou výlučnou odpovědnost, že výrobek odpovídá jmenovaným směrnici.
 DA - Vi erklærer under ansvar at produktet i overensstemmelse med de retningssøjler.
 EN - We hereby declare, under our sole responsibility, that the product is in accordance with the specified Directives.
 FI - Vakuutamme omalla vastuullamme, että tuote täyttää ohjeita.
 FR - Nous déclarons sous notre propre responsabilité que le produit répond aux directives.
 HU - Kizárólagos felelősségünk tudatában kijelentjük, hogy ez a termék megfelel az Európai Unió fennvezetett irányelveinek.
 IT - Noi dichiariamo sotto la nostra esclusiva responsabilità che il prodotto è conforme alle direttive citate.
 NL - Wij verklaren geheel onder eigen verantwoordelijkheid dat het product voldoet aan de gestelde richtlijnen.
 PL - Z pełną odpowiedzialnością oświadczamy, że produkt odpowiada postanowieniom wymienionych dyrektyw.
 PT - Declaramos, sob nossa exclusiva responsabilidade, que o produto está em conformidade com as Diretivas especificadas.
 RO - Declaram pe proprie răspundere că produsul corespunde normelor prevăzute de directivele mai sus menționate.
 SK - Na výlučnú zodpovednosť vyhlasujeme, že výrobok spĺňa požiadavky uvedených smerníc.
 SV - Vi försäkrar att produkten på vårt ansvar är utförd enligt gällande riktlinjer.

55/2 B2 EX (JP09663/2) **100/2 B5** EX (JP0740/1) **75/2 BW1** (JP4687/3) **75/2 M** (JP5037/5) **75/2 M** EX (JP6037/6)
55/4 B6 EX (JP09668/2) **100/4 C2** EX (JP09678/1) **75/2 CW1** (JP4688/1) **75/2 M** EX (JP5037/7) **75/2 M** EX (JP6037/7)
55/4 C2 EX (JP09668/2) **100/4 C5** EX (JP03275/1) **75/4 BW2** (JP4687/7) **75/4 CW2** (JP4723/4) **75/2 M** EX (JP6037/8)
55/4 C5 EX (JP09002/2) **55/4 CW2** (JP4723/5) **75/2 BW1** EX (JP4687/4) **100/2 BW1** EX (JP4687/2) **75/2 M** EX (JP6037/4)
75/4 B6 EX (JP09667/2) **75/4 B6** EX (JP09667/2) **100/2 CW1** EX (JP4737/2) **75/4 BW2** EX (JP4687/8) **100/4 CW3** EX (JP4735/5) **75/2 M** EX (JP6037/8)
75/4 C2 EX (JP09669/2) **75/4 C5** EX (JP09905/2) **75/4 CW2** EX (JP4723/5) **100/4 CW3** EX (JP4735/5) **75/2 M** EX (JP6037/4)

55/2 B2 EX (JP09664/2) **100/2 B5** EX (JP0974/1) **55/4 BW2** EX (JP4826/8) **100/2 BW1** EX (JP4687/2) **75/2 M** EX (JP6037/6)
55/4 B6 EX (JP09668/2) **100/4 C2** EX (JP09679/1) **55/4 CW2** EX (JP4737/3) **100/2 CW1** EX (JP4688/0) **75/2 M** EX (JP6037/3)
55/4 C2 EX (JP09668/2) **100/4 C5** EX (JP03276/1) **75/2 BW1** EX (JP4687/4) **100/4 BW2** EX (JP487/6) **75/2 M** EX (JP6037/8)
55/4 C5 EX (JP09002/2) **75/2 BW1** EX (JP4723/4) **100/4 CW3** EX (JP4735/5) **75/2 M** EX (JP6037/4)

DE - Weitere normative Dokumente CS - Jinými normativními dokumenty DA - Andre normative dokumenter EN - Other normative documents FI - Muitten normien FR - Autres documents normatifs HU - Egyéb szabványos dokumentumok leírások IT - Altri documenti normativi NL - Verdere normatieve documenten PL - Innymi dokumentami normatywnymi PT - Outros documentos normativos RO - Alte acte normative SK - Iným záväzným dokumentom, SV - Vidare normerade dokument.
EN 60034-5-2:2011/AT:2007
EN 60079-14:2014

DE - Weitere normative Dokumente CS - Jinými normativními dokumenty DA - Andre normative dokumenter EN - Other normative documents FI - Muitten normien FR - Autres documents normatifs HU - Egyéb szabványos dokumentumok leírások IT - Altri documenti normativi NL - Verdere normatieve documenten PL - Innymi dokumentami normatywnymi PT - Outros documentos normativos RO - Alte acte normative SK - Iným záväzným dokumentom, SV - Vidare normerade dokument.
EN 60034-5-2:2011/AT:2007
EN 60079-14:2014

JUNG PUMPEN - Stefan Stiges - Industriest. 4-6 - 33803 Steinhagen
 Steinshagen, 05-01-2022

JUNG PUMPEN - Stefan Stiges - Industriest. 4-6 - 33803 Steinhagen
 Steinshagen, 05-01-2022

Physikalisch-Technische Bundesanstalt
 Zertifizierungsektor Explosionsenschutz (102)
 Bundesallee 100 - 38118 Braunschweig - Germany

 Stefan Stiges, General Manager

Physikalisch-Technische Bundesanstalt
 Zertifizierungsektor Explosionsenschutz (102)
 Bundesallee 100 - 38118 Braunschweig - Germany

 Stefan Stiges, General Manager



UKCA-Declaration of Conformity

Legislation - Designated Standards

- Supply of Machinery (Safety) Regulations 2008 (MD) EN 809;1996/AC:2010, EN ISO 12100:2010
- The Restriction of the Use of Certain Hazardous Substance in Electrical and Electronic Equipment Regulations 2012 (RoHS)
- Electromagnetic Compatibility Regulations 2016 (EMC) EN 60034-1: 2010/AC: 2010, EN 61000-3-2:2014, EN 61000-3-3:2013

Name and address of the manufacturer: JUNG PUMPEN GmbH - Industriestr. 4-6 - 33803 Steinhagen - Germany - www.jung-pumpen.de

We hereby declare, under our sole responsibility, that the product is in accordance with the specified Legislation.

- | | | | |
|---------------------|----------------------|---------------------|------------------|
| 55/2 B2 (JP09863/2) | 100/2 B5 (JP09740/1) | 75/2 BW1 (JP46873) | 75/2 M (JP50375) |
| 55/4 B6 (JP00466/3) | 100/4 C2 (JP09678/1) | 75/2 CW1 (JP46881) | 76/2 M (JP50377) |
| 55/4 C2 (JP00487/3) | 100/4 C5 (JP09275/1) | 75/4 BW2 (JP46877) | |
| 55/4 C5 (JP09901/2) | 55/4 BW2 (JP48267) | 75/4 CW2 (JP47234) | |
| 75/2 B5 (JP00465/3) | 55/4 CW2 (JP47372) | 100/2 BW1 (JP46871) | |
| 75/4 B6 (JP00469/3) | | 100/2 CW1 (JP46879) | |
| 75/4 C2 (JP00490/3) | | 100/4 BW2 (JP46875) | |
| 75/4 C5 (JP09904/2) | | 100/4 CW3 (JP47354) | |

Other normative documents:

EN 60034-5:2001/A1:2007

Authorized person for technical documentation
 JUNG PUMPEN - Stefan Sirges - Industriestr. 4-6 - 33804 Steinhagen
 Steinhagen, 09-09-2022



Stefan Sirges, General Manager

Pascal Kollbeck, Sales Manager



EG-Baumusterprüfbescheinigung



- (1) EG-Baumusterprüfbescheinigungsnummer
- (2) Geräte und Schutzsysteme zur bestimmungsgemäßen Verwendung in explosionsgefährdeten Bereichen - Richtlinie 94/9/EG
- (3) PTB 08 ATEX 1115 X
- (4) Gerät: Tauchpumpenmotor der Typen D 112 - ...
- (5) Hersteller: Jung Pumpen GmbH
- (6) Anschrift: Industriestraße 4 - 6, 33803 Steinhausen, Deutschland
- (7) Die Bauart dieses Gerätes sowie die verschiedenen zulässigen Ausführungen sind in der Anlage und den darin aufgeführten Unterlagen zu dieser Baumusterprüfbescheinigung festgelegt.
- (8) Die Physikalisch-Technische Bundesanstalt bescheinigt als benannte Stelle Nr. 0102 nach Artikel 9 der Richtlinie des Rates der Europäischen Gemeinschaften vom 23. März 1994 (94/9/EG) die Erfüllung der grundlegenden Sicherheits- und Gesundheitsanforderungen für die Konzeption und den Bau von Geräten und Schutzsystemen zur bestimmungsgemäßen Verwendung in explosionsgefährdeten Bereichen gemäß Anhang II der Richtlinie.
- (9) Die Ergebnisse der Prüfung sind in dem vertraulichen Prüfbericht PTB Ex 08-18363 festgehalten.
- (10) Die grundlegenden Sicherheits- und Gesundheitsanforderungen werden erfüllt durch Übereinstimmung mit EN 60079-0:2006
- (11) Falls das Zeichen „X“ hinter der Bescheinigungsnummer steht, wird auf besondere Bedingungen für die sichere Anwendung des Gerätes in der Anlage zu dieser Bescheinigung hingewiesen.
- (12) Diese EG-Baumusterprüfbescheinigung bezieht sich nur auf Konzeption und Prüfung des festgelegten Gerätes gemäß Richtlinie 94/9/EG. Weitere Anforderungen dieser Richtlinie gelten für die Herstellung und das Inverkehrbringen dieses Gerätes. Diese Anforderungen werden nicht durch diese Bescheinigung abgedeckt.

(12) Die Kennzeichnung des Gerätes muss die folgenden Angaben enthalten:

II 2 G Ex d IIB T4

Zertifizierungssektor Explosionsschutz

Im Auftrag



Dr.-Ing. U. Klausmeyer
Direktor und Professor

Braunschweig, 3. Februar 2009



EC-TYPE-EXAMINATION CERTIFICATE

(Translation)



- (1) Equipment and Protective Systems Intended for Use in Potentially Explosive Atmospheres - Directive 94/9/EC
- (2) EC-type-examination Certificate Number: PTB 08 ATEX 1115 X
- (3) Equipment: Submersible pump motors, type D 112 - ...
- (4) Manufacturer: Jung Pumpen GmbH
- (5) Address: Industriestraße 4 - 6, 33803 Steinhausen, Germany
- (6) This equipment and any acceptable variation thereto are specified in the schedule to this certificate and the documents therein referred to.
- (7) The Physikalisch-Technische Bundesanstalt, notified body No. 0102 in accordance with Article 9 of the Council Directive 94/9/EC of 23 March 1994, certifies that this equipment has been found to comply with the Essential Health and Safety Requirements relating to the design and construction of equipment and protective systems intended for use in potentially explosive atmospheres, given in Annex II to the Directive.
- (8) The examination and test results are recorded in the confidential report PTB Ex 08-18363.
- (9) Compliance with the Essential Health and Safety Requirements has been assured by compliance with EN 60079-0:2006
- (10) If the sign "X" is placed after the certificate number, it indicates that the equipment is subject to special conditions for safe use specified in the schedule to this certificate.
- (11) This EC-type-examination Certificate relates only to the design, examination and tests of the specified equipment in accordance to the Directive 94/9/EC. Further requirements of the Directive apply to the manufacturing process and supply of this equipment. These are not covered by this certificate.
- (12) The marking of the equipment shall include the following:

II 2 G Ex d IIB T4

Zertifizierungssektor Explosionsschutz

By order:



Dr.-Ing. U. Klausmeyer
Direktor und Professor

Braunschweig, February 3, 2009

(13) Anlage

(14) EG-Baumusterprüfbescheinigung PTB 08 ATEX 1115 X

(15) Beschreibung des Gerätes

Bei dem Betriebsmittel handelt es sich um eine drehende elektrische Maschine zum Antrieb von Pumpen. Der Motorteil ist in der Zündschutzart Druckfeste Kapselung "d" ausgeführt. Die Stromzufuhr erfolgt über schwere Gummischlauchleitung NSSHou oder ein mindestens gleichwertiges, geprüftes Kabel.

(16) Prüfbericht PTB Ex 08-18363

(17) Besondere Bedingungen

Eine Reparatur an den zünddurchschlagsicheren Spalten darf nur entsprechend den konstruktiven Vorgaben des Herstellers erfolgen. Die Reparatur entsprechend den Werten der Tabelle 1 bzw. 2 der EN 60079-1 ist nicht zulässig.

Zusätzliche Hinweise für den sicheren Betrieb:

Für den Ein- und Anbau von Komponenten (Anschlussräume, Durchführungen, Ex-Kabel- und Leitungseinführungen, Anschlussteile) sind nur solche zugelassen, die mindestens dem auf dem Deckblatt angegebenen Normenstand technisch entsprechen und für die eine gesonderte Prüfbescheinigung vorliegt. Die in den entsprechenden Bescheinigungen der Komponenten aufgeführten Einsatzbedingungen sind dabei unbedingt zu beachten und müssen mindestens den in der vorstehenden EG-Baumusterprüfbescheinigung spezifizierten Einsatzbedingungen entsprechen.

Für den Abschluss des druckfesten Raumes sind mindestens Schrauben der Festigkeitsklasse A2-70 zu verwenden.

1. Für den Betrieb am Netz

Die Motoren dieses Typs müssen zusätzlich zu thermisch verzögerten Überstromauslösern durch 2 Temperaturbegrenzer (150 °C) geschützt werden.

2. Für den Betrieb am Umrichter

2.1 Die Motoren müssen durch eine Einrichtung zur direkten Temperaturüberwachung geschützt werden. Diese besteht aus

in die Wicklung eingebauten Temperaturfühlern
(Kaltleiter DIN 44 082-150) und einem Auslösegerät
mit dem Prüfzeichen PTB 3.53 – PTC/A bzw. nach
Richtlinie 94/9/EG auf Funktion geprüft.

(13) SCHEDULE

(14) EC-TYPE-EXAMINATION CERTIFICATE PTB 08 ATEX 1115 X

(15) Description of equipment

The equipment is a rotary electric machine used for driving pumps. The motor section is designed to Flameproof Enclosure "d" type of protection. For power supply, heavy-duty NSSHou rubber hose lines are used or tested cables of equivalent or better quality.

(16) Test Report PTB Ex 08-18363

(17) Special conditions for safe use

Repairs of the flameproof joints must be made in compliance with the structural specifications provided by the manufacturer. Repairs must not be made on the basis of values specified in tables 1 and 2 of EN 60079-1.

Additional notes for safe operation

Components attached or installed (terminal compartments, bushings, 'Ex' cable glands, connectors) must be of a technical standard that at least complies with the specifications on the cover sheet and for which a separate examination certificate has been issued. The operating conditions specified in component certificates must be followed and they must as a minimum conform with the operating conditions specified in the above EC Type Examination Certificate.
Screws complying with strength class A2-70 as a minimum must be used for enclosure of the flameproof chamber.

1. For mains operation

Motors of this type must be protected by two temperature limiters (150 °C) in addition to thermally delayed overcurrent releases.

2. For converter operation

2.1 The motors must be protected by a device providing for direct temperature monitoring.

temperature sensors embedded in the winding
(PTC resistor DIN 44 082-150) and a tripping device
with test mark PTB 3.53 – PTC/A or function tested
in accordance with Directive 94/9/EC.

The concerted operation of motor and monitoring device will be indicated by a plate additionally provided on the motor.

Die Zusammengehörigkeit von Motor und Überwachungseinrichtung wird auf dem Motor durch ein Zusatzschild gekennzeichnet.

Überstromschutzeinrichtungen mit stromabhängig verzögerter Auslösung sind hierbei als zusätzliche Überwachung anzusehen.

2.2 Die Motoren werden im Frequenzbereich von 15 Hz bis 50/60 Hz betrieben. Die Ausgangsspannung des Umrichters wird dabei so geregelt, dass im Bereich von 15 Hz bis 50/60 Hz eine annähernd lineare Abhängigkeit zwischen der Spannung und der Frequenz eingehalten wird, d.h. Einhaltung eines praktisch konstanten Maschinenflusses entsprechend den Bemessungsdaten.

Die Strombegrenzung des Umrichters wird höchstens auf den 3fachen Motorstrom eingestellt.

Zusatz- und Überwachungseinrichtungen mit eigener Bescheinigung und Explosionsschutzkennzeichnung sind den am Einsatzort vorliegenden Bedingungen entsprechend auszuwählen.

Überwachungseinrichtungen müssen den Anforderungen nach Richtlinie 94/9/EG, Anhang II, Abschnitt 1.5 und EN 1127-1 genügen.

Weitere einschränkende Hinweise für den sicheren Betrieb sind dem jeweiligen Datenblatt für die Maschinenauslegung zu entnehmen.

Elektrisch-thermische Motorauslegung

Die Datenblätter 01 bis 06 der EG-Baumusterprüfbescheinigung PTB 02 ATEX 1043 sind gleichzeitig Bestandteil der vorstehenden EG-Baumusterprüfbescheinigung.

(18) Grundlegende Sicherheits- und Gesundheitsanforderungen

Erfüllt durch Übereinstimmung mit den vorgenannten Normen.

Zertifizierungssektor Explosionsschutz
Im Auftrag

Dr.-Ing. U. Klausmeyer
Direktor und Professor

Braunschweig, 3. Februar 2009

EG-Baumusterprüfbescheinigungen ohne Unterschrift und ohne Siegel haben keine Gültigkeit.
Diese EG-Baumusterprüfbescheinigung darf nur unverändert weiterverbreitet werden.
Auszüge oder Änderungen bedürfen der Genehmigung der Physikalisch-Technischen Bundesanstalt.
Physikalisch-Technische Bundesanstalt • Bundesallee 100 • 38116 Braunschweig • DEUTSCHLAND

Seite 3/3

Overcurrent protection devices with current-based delayed tripping must in this context be regarded as additional monitoring devices.

2.2 The motors will be operated within the 15 Hz to 50/60 Hz frequency range. The converter output voltage will be controlled so that within the 15 Hz to 50/60 Hz range an approximately linear relationship between voltage and frequency will be maintained, i.e. that a basically constant machine flow in compliance with the ratings will be maintained.

The converter current limitation will be set at three times the motor current as a maximum.

Supplementary and monitoring devices with their own certificate and explosion protection marking have to be selected so that they comply with the conditions at the place of installation.

Monitoring devices must satisfy the requirements in Directives 94/9/EC, Annex II, section 1.5, and EN 1127-1.

For any additional notes concerning restrictions for safe use, reference is made to the data sheet for the machine design.

Electro-thermal motor design

Data sheets 01 to 06 of EC Type Examination Certificate PTB 02 ATEX 1043 also form part of the above EC Type Examination Certificate.

(18) Essential health and safety requirements

Met by compliance with the afore-mentioned Standards.

Zertifizierungssektor Explosionsschutz

By order:

Dr.-Ing. U. Klausmeyer
Direktor und Professor

Braunschweig, February 3, 2009

EC-type-examination Certificates without signature and official stamp shall not be valid. The certificates may be circulated only without alteration. Extracts or alterations are subject to approval by the Physikalisch-Technische Bundesanstalt. In case of dispute, the German text shall prevail.

Physikalisch-Technische Bundesanstalt • Bundesallee 100 • 38116 Braunschweig • GERMANY

sheet 3/3

Physikalisch-Technische Bundesanstalt

Braunschweig und Berlin



Datenblatt 01 zur EG-Baumusterprüfbescheinigung PTB 02 ATEX 1043

der Firma Jung Pumpen GmbH & Co., 33803 Steinhausen, Deutschland

für den Tauchpumpenmotor Typ D 112 - 2 / 110 D bzw. D 112 - 2 / 110 DK

Elektrische Bemessungsdaten

Diese Bescheinigung gilt unter der Voraussetzung, dass sich die Motoren dieses Typs hinsichtlich der elektrischen und thermischen Beanspruchungen nur unwesentlich von dem geprüften Muster unterscheiden, für die folgenden Ausführungen:

Leistung (Aufnahme):	218 - 242	380 - 420	655 - 725	6,4	6,55
Spannung:	19,1	11	6,4		V
Strom:		0,88			A
Leistungsfaktor:		50 oder 60			Hz
Frequenz:		2860 bzw. 3460			min ⁻¹
Drehzahl:	max.	40			°C
Umgebungstemperatur:		4,1			
I_n/I_N :					
Betriebsart:			S1 bei eingetauchtem Motorteil, S2 15 min., S3 20 % ¹⁾		

¹⁾ Spieldauer 10 min.

Die Bescheinigung gilt auch für Motoren mit einer geringeren Leistung, jedoch maximal bis zu 6,55 kW Aufnahmeleistung.

Die entsprechenden Daten sind vom Hersteller auf dem Leistungsschild anzugeben.

Gegenüber den Bemessungswerten darf die Netzspannung bis zu $\pm 5\%$ und die Netzfrequenz bis zu $\pm 2\%$ entsprechend dem Bereich A nach IEC 34-1 schwanken.

Temperaturüberwachung

Bei Motoren mit Kaltleiterschutz muss sichergestellt sein, dass bei festgebremstem Läufer und einem Verhältnis $I_n/I_N = 4,1$ die Auslösezeit $t_A = 31$ s mit einer Toleranz von $\pm 20\%$ eingehalten wird. Dabei ist vom kalten Motor (20°C) und einer Netzspannung 400 V bei 50 Hz auszugehen.

Zur Vermeidung unzulässig hoher Temperaturen am Motorteil sind folgende Bedingungen zu beachten: Bei der Betriebsart S1 muss sichergestellt werden, dass der komplette Motor in das Fördermedium eingetaucht ist.

Bei der Betriebsart S2 15 Minuten sowie bei der Betriebsart S3 20 % mit einer Spieldauer von 10 Minuten muss mindestens das Pumpengehäuse komplett in das Fördermedium eingetaucht sein. Die Einhaltung der Betriebsart S2 bzw. S3 ist durch die elektrische Steuerung zu gewährleisten.

Bei Nichterhaltung einer dieser Bedingungen für die entsprechende Betriebsart, muss der Motor unverzüglich ausgeschaltet werden.

Prüfbericht PTB Ex 02-32058

Zertifizierungsstelle Explosionsschutz
im Auftrag



Dr.-Ing. U. Engel
Regierungsdirektor

Blatt 1/1

Physikalisch-Technische Bundesanstalt

Braunschweig und Berlin



DATA SHEET 01 TO EC-TYPE-EXAMINATION CERTIFICATE PTB 02 ATEX 1043

Manufacturer: Jung Pumpen GmbH & Co, 33803 Steinhausen, Germany

for the submersible pump motor type D 112 - 2 / 110 D or D 112 - 2 / 110 DK

Ratings

This certificate is valid for the following designs providing the motors of this type differ only negligibly from the sample tested as regards the electrical and thermal stresses:

Power(input):	218 - 242	380 - 420	655 - 725	6,4	6,55
Voltage:	19,1	11	6,4		V
Current:		0,88			A
Power factor:		50 or 60			Hz
Frequency:		2860 or 3460			min ⁻¹
Speed:	max.	40			°C
temperature of cooling medium:		4,1			
I_n/I_N ratio:					
Duty Type:			S1 with immersed motor section, S2 15 min., S3 20 % ¹⁾		

¹⁾ cycle time 10 min.

The certificate is also valid for motors with a lower power input, but up to 6,55 kW as a maximum.

The manufacturer must state the corresponding data on the nameplate.

The mains voltage may vary by up to $\pm 5\%$ and the mains frequency by up to $\pm 2\%$ from the rated values, in keeping with range A according to IEC 34-1.

Temperature monitoring

For motors with PTC thermistor are to be ensured that with a locked rotor and a ratio of $I_n/I_N = 4,1$, the release time $t_A = 31$ s will be maintained at a tolerance of $\pm 20\%$. This applies for a cold motor (20 °C) and a rated voltage of 400 V at 50 Hz.

To avoid inadmissibly high temperatures on the motor the following conditions are to be considered:

For duty type S1 it must be ensured that the complete motor is immersed into the cooling medium.

For duty type S2 15 minutes as well as for duty type S3 20% with a cycle time of 10 minutes the pump case must be completely immersed into the cooling medium. The adherence to the duty type S2 and/or S3 is to be ensured by the electrical control.

During disregard one of these conditions for the respective duty type, the motor must be switched off immediately.

Report PTB Ex 02-32058

Zertifizierungsstelle Explosionsschutz
By order

Dr.-Ing. U. Engel
Regierungsdirektor



Braunschweig, May 30, 2002

page 1/1

Elektrische Bemessungsdaten

Diese Bescheinigung gilt unter der Voraussetzung, dass sich die Motoren dieses Typs hinsichtlich der elektrischen und thermischen Beanspruchungen nur unwesentlich von dem geprüften Muster unterscheiden, für die folgenden Ausführungen:

Leistung (Aufnahme):	8,05	kW		
Spannung:	218 - 242	380 - 420	655 - 725	V
Strom:	24,0	13,7	7,9	A
Leistungsfaktor:	0,86 - 0,82			
Frequenz:	50 oder 60			
Drehzahl:	2910 bzw. 3510			
Umgebungstemperatur:	max.	40	Hz	min ⁻¹
I_w/I_N :	5,6			

Betriebsart: S1 bei eingetauchtem Motorteil, S2 20 min., S3 25 %¹⁾

¹⁾ Spieldauer 10 min.

Die Bescheinigung gilt auch für Motoren mit einer geringeren Leistung, jedoch maximal bis zu

8,05 kW Aufnahmelleistung.

Die entsprechenden Daten sind vom Hersteller auf dem Leistungsschild anzugeben.

Gegenüber den Bemessungswerten darf die Netzspannung bis zu $\pm 5\%$ und die Netzfrequenz bis zu $\pm 2\%$ entsprechend dem Bereich A nach IEC 34-1 schwanken.

Temperaturüberwachung

Bei Motoren mit Kaltleiterschutz muss sichergestellt sein, dass bei festgebremstem Läufer und einem Verhältnis $I_w/I_N = 5,6$ die Auslösezeit $t_{th} = 22$ s mit einer Toleranz von $\pm 20\%$ eingehalten wird. Dabei ist vom kalten Motor (20°C) und einer Netzspannung 400 V bei 50 Hz auszugehen.

Zur Vermeidung unzulässig hoher Temperaturen am Motorteil sind folgende Bedingungen zu beachten: Bei der Betriebsart S1 muss sichergestellt werden, dass der komplette Motor in das Fördermedium eingetaucht ist.

Bei der Betriebsart S2 20 Minuten sowie bei der Betriebsart S3 25 % mit einer Spieldauer von 10 Minuten muss mindestens das Pumpengehäuse komplett in das Fördermedium eingetaucht sein.

Die Einhaltung der Betriebsart S2 bzw. S3 ist durch die elektrische Steuerung zu gewährleisten. Bei Nichteinhaltung einer dieser Bedingungen für die entsprechende Betriebsart, muss der Motor unverzüglich ausgeschaltet werden.

Prüfbericht PTB Ex 02-32058

Zertifizierungsstelle Explosionsschutz

Im Auftrag



A. Engel
Dr.-Ing. U. Engel
Regierungsdirektor

Braunschweig, 30. Mai 2002

Ratings

This certificate is valid for the following designs providing the motors of this type differ only negligibly from the sample tested as regards the electrical and thermal stresses:

Power (input):	8,05	kW		
Voltage:	218 - 242	380 - 420	655 - 725	V
Current:	24,0	13,7	7,9	A
Power factor:	0,86 - 0,82			
Frequency:	50 or 60			
Speed:	2910 or 3510			
temperature of cooling medium:	max.	40	Hz	min ⁻¹
I_w/I_N ratio:	5,6			

Duty Type: S1 with immersed motor section, S2 20 min., S3 25%¹⁾

¹⁾ cycle time 10 min.

The certificate is also valid for motors with a lower power input, but up to 8,05 kW as a maximum. The manufacturer must state the corresponding data on the nameplate.

The mains voltage may vary by up to $\pm 5\%$ and the mains frequency by up to $\pm 2\%$ from the rated values, in keeping with range A according to IEC 34-1.

Temperature monitoring

For motors with PTC thermistor are to be ensured that with a locked rotor and a ratio of $I_w/I_N = 5,6$, the release time $t_{th} = 22$ s will be maintained at a tolerance of $\pm 20\%$. This applies for a cold motor (20 °C) and a rated voltage of 400 V at 50 Hz.

To avoid inadmissibly high temperatures on the motor the following conditions are to be considered: For duty type S1 it must be ensured that the complete motor is immersed into the cooling medium.

For duty type S2 20 minutes as well as for duty type S3 25% with a cycle time of 10 minutes the pump case must be complete immersed into the cooling medium.

The adherence to the duty type S2 and/or S3 is to be ensured by the electrical control. During disregard one of these conditions for the respective duty type, the motor must be switched off immediately.

Report PTB Ex 02-32058

Zertifizierungsstelle Explosionsschutz

By order



A. Engel
Dr.-Ing. U. Engel
Regierungsdirektor

Braunschweig, May 30, 2002

Physikalisch-Technische Bundesanstalt

Braunschweig und Berlin

Datenblatt 03 zur EG-Baumusterprüfbescheinigung PTB 02 ATEX 1043

der Firma Jung Pumpen GmbH & Co., 33803 Steinhausen, Deutschland

für den Tauchpumpenmotor Typ D 112 - 2 / 200 B bzw. D 112 - 2 / 200 BK

Elektrische Bemessungsdaten

Diese Bescheinigung gilt unter der Voraussetzung, dass sich die Motoren dieses Typs hinsichtlich der elektrischen und thermischen Beanspruchungen nur unwesentlich von dem geprüften Muster unterscheiden, für die folgenden Ausführungen.

Leistung (Aufnahme):	12.2	kW		
Spannung:	218 - 242	380 - 420 655 - 725	V	
Strom:	36,5	21	12,2	A
Leistungsfaktor:	0,85 - 0,82			
Frequenz:	50 oder 60			
Drehzahl:	2892 bzw. 3492			
Umgebungstemperatur:	max.	40	°C	
I_k/I_N :	5,8			
Betriebsart:	S1 bei eingetauchtem Motorteil, S2 20 min., S3 20 % ¹⁾			
¹⁾ Spieldauer	10 min.			

Die Bescheinigung gilt auch für Motoren mit einer geringeren Leistung, jedoch maximal bis zu 12,2 kW Aufnahmeleistung.

Die entsprechenden Daten sind vom Hersteller auf dem Leistungsschild anzugeben.

Gegenüber den Bemessungswerten darf die Netzspannung bis zu $\pm 5\%$ und die Netzfrequenz bis zu $\pm 2\%$ entsprechend dem Bereich A nach IEC 34-1 schwanken.

Temperaturüberwachung

Bei Motoren mit Kaltleiterschutz muss sichergestellt sein, dass bei festgebremstem Läufer und einem Verhältnis $I_k/I_N = 5,8$ die Auslösezeit $t_A = 19,5$ s mit einer Toleranz von $\pm 20\%$ eingehalten wird. Dabei ist vom kalten Motor (20°C) und einer Netzspannung 400 V bei 50 Hz auszugehen.

Zur Vermeidung unzulässig hoher Temperaturen am Motorteil sind folgende Bedingungen zu beachten: Bei der Betriebsart S1 muss sichergestellt werden, dass der komplette Motor in das Fördermedium eingetaucht ist.

Bei der Betriebsart S2 20 Minuten sowie bei der Betriebsart S3 20 % mit einer Spieldauer von 10 Minuten muss mindestens das Pumpengehäuse komplett in das Fördermedium eingetaucht sein. Die Einhaltung der Betriebsart S2 bzw. S3 ist durch die elektrische Steuerung zu gewährleisten.

Bei Nichterhaltung einer dieser Bedingungen für die entsprechende Betriebsart, muss der Motor unverzüglich ausgeschaltet werden.

Prüfbericht PTB Ex 02-32058

Zertifizierungsstelle Explosionsschutz

Im Auftrag

A. Engel

Dr.-Ing. U. Engel
Regierungsdirektor



Braunschweig, 30. Mai 2002

Blatt 1/1

PTB

Physikalisch-Technische Bundesanstalt

Braunschweig und Berlin

DATA SHEET 03 TO EC-TYPE-EXAMINATION CERTIFICATE PTB 02 ATEX 1043

Manufacturer: Jung Pumpen GmbH & Co., 33803 Steinhausen, Germany

for the submersible-pump motor type D 112 - 2 / 200 B or D 112 - 2 / 200 BK

Ratings

This certificate is valid for the following designs providing the motors of this type differ only negligibly from the sample tested as regards the electrical and thermal stresses:

Power (input):	12.2	kW		
Voltage:	218 - 242	380 - 420 655 - 725	V	
Current:	36,5	21	12,2	A
Power factor:	0,85 - 0,82			
Frequency:	50 or 60			
Speed:	2892 or 3492			
temperature of cooling medium:	max.	40	°C	
I_k/I_N ratio:	5,8			
Duty Type:	S1 with immersed motor section, S2 20 min., S3 20% ¹⁾			
¹⁾ cycle time	10 min.			

The certificate is also valid for motors with a lower power input, but up to 12.2 kW as a maximum. The manufacturer must state the corresponding data on the nameplate.

The mains voltage may vary by up to $\pm 5\%$ and the mains frequency by up to $\pm 2\%$ from the rated values, in keeping with range A according to IEC 34-1.

Temperature monitoring

For motors with PTC thermistor are to be ensured that with a locked rotor and a ratio of $I_k/I_N = 5,8$, the release time $t_A = 19,5$ s will be maintained at a tolerance of $\pm 20\%$. This applies for a cold motor (20 °C) and a rated voltage of 400 V at 50 Hz.

To avoid inadmissibly high temperatures on the motor the following conditions are to be considered:

For duty type S1 it must be ensured that the complete motor is immersed into the cooling medium.

For duty type S2 20 minutes as well as for duty type S3 20% with a cycle time of 10 minutes the pump case must be completely immersed into the cooling medium.

The adherence to the duty type S2 and/or S3 is to be ensured by the electrical control.

During disregard one of these conditions for the respective duty type, the motor must be switched off immediately.

Report PTB Ex 02-32058

Zertifizierungsstelle Explosionsschutz

By order

A. Engel

Dr.-Ing. U. Engel
Regierungsdirektor



Braunschweig, May 30, 2002

page 1/1

Elektrische Bemessungsdaten

Diese Bescheinigung gilt unter der Voraussetzung, dass sich die Motoren dieses Typs hinsichtlich der elektrischen und thermischen Beanspruchungen nur unwesentlich von dem geprüften Muster unterscheiden, für die folgenden Ausführungen:

Leistung (Aufnahme):	6,39	kW		
Spannung:	218 - 242	380 - 420	655 - 725	V
Strom:	18,8	10,8	6,3	A
Leistungsfaktor:	0,85			
Frequenz:	50 oder 60			Hz
Drehzahl:	1410 bzw. 1710			min ⁻¹
Umgebungstemperatur:	max.	40		°C
I _A /I _N :	3,9			
Betriebsart:	S1 bei eingetauchtem Motorteil, S2 10 min., S3 15 % ¹⁾			
¹⁾ Spieldauer	10 min.			

Die Bescheinigung gilt auch für Motoren mit einer geringeren Leistung, jedoch maximal bis zu 6,39 kW Aufnahmeleistung.

Die entsprechenden Daten sind vom Hersteller auf dem Leistungsschild anzugeben.

Gegenüber den Bemessungswerten darf die Netzspannung bis zu ± 5 % und die Netzfrequenz bis zu ± 2 % entsprechend dem Bereich A nach IEC 34-1 schwanken.

Temperaturüberwachung

Bei Motoren mit Kalteiferschutz muss sichergestellt sein, dass bei festgebremstem Laufer und einem Verhältnis I_A/I_N = 3,9 die Auslösezeit t_A = 19 s mit einer Toleranz von ± 20 % eingehalten wird. Dabei ist vom kalten Motor (20°C) und einer Netzspannung 400 V bei 50 Hz auszugehen.

Zur Vermeidung unzulässig hoher Temperaturen am Motorteil sind folgende Bedingungen zu beachten: Bei der Betriebsart S1 muss sichergestellt werden, dass der komplette Motor in das Fördermedium eingetaucht ist.

Bei der Betriebsart S2 10 Minuten sowie bei der Betriebsart S3 15% mit einer Spieldauer von 10 Minuten muss mindestens das Pumpengehäuse komplett in das Fördermedium eingetaucht sein.

Die Einhaltung der Betriebsart S2 bzw. S3 ist durch die elektrische Steuerung zu gewährleisten. Bei Nichteinhaltung einer dieser Bedingungen für die entsprechende Betriebsart, muss der Motor unverzüglich ausgeschaltet werden.

Prüfbericht PTB Ex 02-32058

Zertifizierungsstelle Explosionsschutz
Im Auftrag



A. Engel
Dr.-Ing. U. Engel
Regierungsdirektor

Braunschweig, 30. Mai 2002

Ratings

This certificate is valid for the following designs providing the motors of this type differ only negligibly from the sample tested as regards the electrical and thermal stresses:

Power (input):	6,39	kW		
Voltage:	218 - 242	380 - 420	655 - 725	V
Current:	18,8	10,8	6,3	A
Power factor:	0,85			
Frequency:	50 or 60			Hz
Speed:	1410 or 1710			min ⁻¹
temperature of cooling medium:	max.	40		°C
I _A /I _N ratio:	3,9			
Duty Type:	S1 with immersed motor section, S2 10 min., S3 15% ¹⁾			
¹⁾ cycle time	10 min.			

The certificate is also valid for motors with a lower power input, but up to 6,39 kW as a maximum. The manufacturer must state the corresponding data on the nameplate.

The mains voltage may vary by up to ± 5% and the mains frequency by up to ± 2% from the rated values, in keeping with range A according to IEC 34-1.

Temperature monitoring

For motors with PTC thermistor are to be ensured that with a locked rotor and a ratio of I_A/I_N = 3,9, the release time t_A = 19 s will be maintained at a tolerance of ± 20 %. This applies for a cold motor (20 °C) and a rated voltage of 400 V at 50 Hz.

To avoid inadmissibly high temperatures on the motor the following conditions are to be considered:

For duty type S1 it must be ensured that the complete motor is immersed into the cooling medium.

For duty type S2 10 minutes as well as for duty type S3 15% with a cycle time of 10 minutes the pump case must be completely immersed into the cooling medium.

The adherence to the duty type S2 and/or S3 is to be ensured by the electrical control.

During disregard one of these conditions for the respective duty type, the motor must be switched off immediately.

Report PTB Ex 02-32058

Zertifizierungsstelle Explosionsschutz
By order



A. Engel
Dr.-Ing. U. Engel
Regierungsdirektor

Braunschweig, May 30, 2002

Physikalisch-Technische Bundesanstalt

Braunschweig und Berlin



Datenblatt 05 zur EG-Baumusterprüfbescheinigung PTB 02 ATEX 1043

der Firma Jung Pumpen GmbH & Co., 33803 Steinhagen, Deutschland

für den Tauchpumpenmotor Typ D 112 - 4 / 140 D bzw. D 112 - 4 / 140 DK

Elektrische Bemessungsdaten

Diese Bescheinigung gilt unter der Voraussetzung, dass sich die Motoren dieses Typs hinsichtlich der elektrischen und thermischen Beanspruchungen nur unwesentlich von dem geprüften Muster unterscheiden, für die folgenden Ausführungen.

Leistung (Aufnahme):	218 - 242	380 - 420	655 - 725	8,25	kW
Spannung:	24,5	14,2	8,2		V
Strom:		0,86 - 0,80			A
Leistungsfaktor:		50 oder 60			Hz
Frequenz:		1409 bzw. 1709			min ⁻¹
Drehzahl:		max.	40		°C
Umgebungstemperatur:			3,9		
I_k/I_n :					
Betriebsart:					

¹⁾ Spieldauer 10 min. S1 bei eingetauchtem Motorteil, S2 11 min., S3 15 % ¹⁾

Die Bescheinigung gilt auch für Motoren mit einer geringeren Leistung, jedoch maximal bis zu 8,25 kW Aufnahmeleistung.

Die entsprechenden Daten sind vom Hersteller auf dem Leistungsschild anzugeben.

Gegenüber den Bemessungswerten darf die Netzspannung bis zu $\pm 5\%$ und die Netzfrequenz bis zu $\pm 2\%$ entsprechend dem Bereich A nach IEC 34-1 schwanken.

Temperaturüberwachung

Bei Motoren mit Kalleiterschutz muss sichergestellt sein, dass bei festgebremstem Laufer und einem Verhältnis $I_k/I_n = 3,9$ die Auslösezeit $t_a = 20,6$ s mit einer Toleranz von $\pm 20\%$ eingehalten wird. Dabei ist vom kalten Motor (20 °C) und einer Netzspannung 400 V bei 50 Hz auszugehen.

Zur Vermeidung unzulässig hoher Temperaturen am Motorteil sind folgende Bedingungen zu beachten: Bei der Betriebsart S1 muss sichergestellt werden, dass der komplette Motor in das Fördermedium eingetaucht ist.

Bei der Betriebsart S2 11 Minuten sowie bei der Betriebsart S3 15% mit einer Spieldauer von 10 Minuten muss mindestens das Pumpengehäuse komplett in das Fördermedium eingetaucht sein.

Die Einhaltung der Betriebsart S2 bzw. S3 ist durch die elektrische Steuerung zu gewährleisten. Bei Nichteinhalten einer dieser Bedingungen für die entsprechende Betriebsart, muss der Motor unverzüglich ausgeschaltet werden.

Prüfbericht PTB Ex 02-32058

Zertifizierungsstelle Explosionsschutz

Braunschweig, 30. Mai 2002

Im Auftrag



Dr.-Ing. U. Engel
Regierungsdirektor

Blatt 1/1



Physikalisch-Technische Bundesanstalt

Braunschweig und Berlin

DATA SHEET 05 TO EG-TYPE-EXAMINATION CERTIFICATE PTB 02 ATEX 1043

Manufacturer: Jung Pumpen GmbH & Co, 33803 Steinhagen, Germany

for the submersible-pump motor type D 112 - 4 / 140 D or D 112 - 4 / 140 DK

Ratings

This certificate is valid for the following designs providing the motors of this type differ only negligibly from the sample tested as regards the electrical and thermal stresses:

Power (input):	218 - 242	380 - 420	655 - 725	8,25	kW
Voltage:	24,5	14,2	8,2		V
Current:		0,86 - 0,80			A
Power factor:		50 or 60			Hz
Frequency:		1409 or 1709			min ⁻¹
Speed:		max.	40		°C
temperature of cooling medium:			3,9		
I_k/I_n ratio:					
Duty Type:					

¹⁾ cycle time 10 min. S1 with immersed motor section, S2 11 min., S3 15% ¹⁾

The certificate is also valid for motors with a lower power input, but up to 8,25 kW as a maximum. The manufacturer must state the corresponding data on the nameplate.

The mains voltage may vary by up to $\pm 5\%$ and the mains frequency by up to $\pm 2\%$ from the rated values, in keeping with range A according to IEC 34-1.

Temperature monitoring

For motors with PTC thermistor are to be ensured that with a locked rotor and a ratio of $I_k/I_n = 3,9$, the release time $t_a = 20,6$ s will be maintained at a tolerance of $\pm 20\%$. This applies for a cold motor (20 °C) and a rated voltage of 400 V at 50 Hz.

To avoid inadmissibly high temperatures on the motor the following conditions are to be considered:

For duty type S1 it must be ensured that the complete motor is immersed into the cooling medium.

For duty type S2 11 minutes as well as for duty type S3 15% with a cycle time of 10 minutes the pump case must be completely immersed into the cooling medium.

The adherence to the duty type S2 and/or S3 is to be ensured by the electrical control.

During disregard one of these conditions for the respective duty type, the motor must be switched off immediately.

Report PTB Ex 02-32058

Zertifizierungsstelle Explosionsschutz

Braunschweig, May 30, 2002

By order



Dr.-Ing. U. Engel
Regierungsdirektor

page 1/1

Braunschweig und Berlin

Datenblatt 06 zur EG-Baumusterprüfbescheinigung PTB 02 ATEX 1043

der Firma Jung Pumpen GmbH & Co., 33803 Steinhagen, Deutschland

für den Tauchpumpenmotor Typ D 112 - 4 / 200 B bzw. D 112 - 4 / 200 BK

Bemessungsgrößen und Daten

Diese Bescheinigung gilt unter der Voraussetzung, dass sich die Motoren dieses Typs hinsichtlich der elektrischen und thermischen Beanspruchungen nur unwesentlich von dem geprüften Muster unterscheiden, für die folgenden Ausführungen:

Leistung (Aufnahme):	12,95	kW		
Spannung:	218 - 242	380 - 420	655 - 725	V
Strom:	36,5	21	12,2	A
Leistungsfaktor:	0,87			
Frequenz:	50 oder 60			Hz
Drehzahl:	1410 bzw. 1710			min ⁻¹
Umgebungstemperatur:	max.	40		°C
I_d/I_N :	3,9			
Betriebsart:	S1 bei eingetauchtem Motorteil, S2 10 min., S3 15 % ¹⁾			
¹⁾ Spieldauer	10 min.			

Die Bescheinigung gilt auch für Motoren mit einer geringeren Leistung, jedoch maximal bis zu 12,95 kW Aufnahmeleistung.

Die entsprechenden Daten sind vom Hersteller auf dem Leistungsschild anzugeben.

Gegenüber den Bemessungswerten darf die Netzspannung bis zu $\pm 5\%$ und die Netzfrequenz bis zu $\pm 2\%$ entsprechend dem Bereich A nach IEC 34-1 schwanken.

Es sind nur Anschlusskabel oder -leitungen mit erhöhter Wärmebeständigkeit und einer Grenztemperatur von mindestens 90 °C zu verwenden.

Temperaturüberwachung

Bei Motoren mit Kaltleiterschutz muss sichergestellt sein, dass bei festgebremstem Läufer und einem Verhältnis $I_d/I_N = 3,9$ die Auslösezeit $t_A = 20$ s mit einer Toleranz von $\pm 20\%$ eingehalten wird. Dabei ist vom kalten Motor (20 °C) und einer Netzspannung 400 V bei 50 Hz auszugehen.

Zur Vermeidung unzulässig hoher Temperaturen am Motorteil sind folgende Bedingungen zu beachten: Bei der Betriebsart S1 muss sichergestellt werden, dass der komplette Motor in das Fördermedium eingetaucht ist.

Bei der Betriebsart S2 10 Minuten sowie bei der Betriebsart S3 15% mit einer Spieldauer von 10 Minuten muss mindestens das Pumpengehäuse komplett in das Fördermedium eingetaucht sein. Die Einhaltung der Betriebsart S2 bzw. S3 ist durch die elektrische Steuerung zu gewährleisten. Bei Nichteinhaltung einer dieser Bedingungen für die entsprechende Betriebsart, muss der Motor unverzüglich ausgeschaltet werden.

Prüfbericht PTB Ex 02-32058

Im Auftrag



A. Engel
Dr.-Ing. U. Engel
Regierungsdirektor

Braunschweig, 14. Juni 2002

Blatt 1/1

Braunschweig und Berlin

DATA SHEET 06 TO EC-TYPE-EXAMINATION CERTIFICATE PTB 02 ATEX 1043

Manufacturer: Jung Pumpen GmbH & Co., 33803 Steinhagen, Germany

for the submersible-pump motor type D 112 - 4 / 200 B or D 112 - 4 / 200 BK

 Ratings

This certificate is valid for the following designs providing the motors of this type differ only negligibly from the sample tested as regards the electrical and thermal stresses:

Power (input):	12,95	kW		
Voltage:	218 - 242	380 - 420	655 - 725	V
Current:	36,5	21	12,2	A
Power factor:	0,87			
Frequenz:	50 or 60			Hz
Speed:	1410 or 1710			min ⁻¹
temperature of cooling medium:	max.	40		°C
I_d/I_N ratio:	3,9			
Duty Type:	S1 with immersed motor section, S2 10 min., S3 15% ¹⁾			
¹⁾ cycle time	10 min.			

The certificate is also valid for motors with a lower power input, but up to 12,95 kW as a maximum. The manufacturer must state the corresponding data on the nameplate.

The mains voltage may vary by up to $\pm 5\%$ and the mains frequency by up to $\pm 2\%$ from the rated values, in keeping with range A according to IEC 34-1.

For this motor are only connecting cables or lines with increased thermal endurance and a temperature limit of at least 90 °C to used.

Temperature monitoring

For motors with PTC thermistor are to be ensured that with a locked rotor and a ratio of $I_d/I_N = 3,9$, the release time $t_A = 20$ s will be maintained at a tolerance of $\pm 20\%$. This applies for a cold motor (20 °C) and a rated voltage of 400 V at 50 Hz.

To avoid inadmissibly high temperatures on the motor the following conditions are to be considered:

For duty type S1 it must be ensured that the complete motor is immersed into the cooling medium.

For duty type S2 10 minutes as well as for duty type S3 15% with a cycle time of 10 minutes the pump case must be complete immersed into the cooling medium. The adherence to the duty type S2 and/or S3 is to be ensured by the electrical control.

During disregard one of these conditions for the respective duty type, the motor must be switched off immediately.

Report PTB Ex 02-32058

By order



A. Engel
Dr.-Ing. U. Engel
Regierungsdirektor

Braunschweig, June 14, 2002



J. Müller

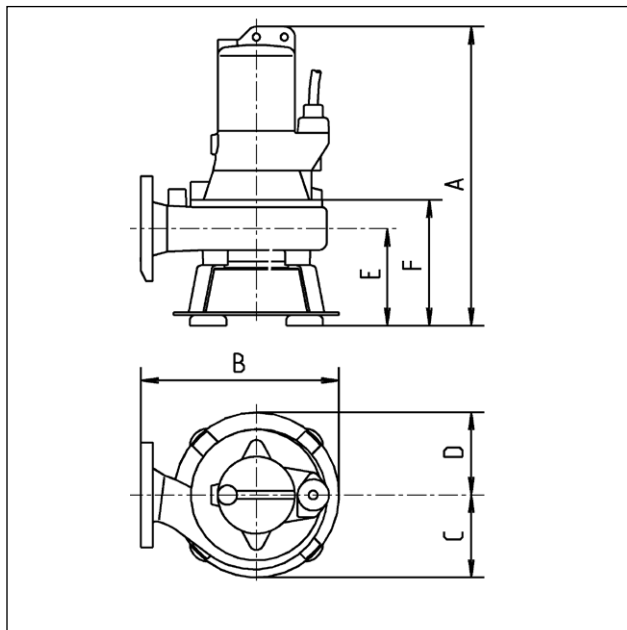

Page 1/1



Technische Daten | Technical data | Caractéristiques techniques | Technische gegevens |
 Dados técnicos | Dati tecnici | Dane techniczne | Technické údaje | Technické údaje |
 Műszaki adatok | Date tehnice



	A	B	C	D	E	F
55/2 B2	700	395	145	135	185	240
55/4 B6	740	520	235	195	210	290
55/4 C2	770	580	260	215	240	320
55/4 C5	775	480	230	195	240	320
75/2 B5	725	460	195	195	215	280
75/4 B6	740	520	235	195	210	290
75/4 C2	770	580	260	215	240	320
75/4 C5	775	480	230	195	240	320
100/2 B5	785	460	195	195	215	280
100/4 C2	830	580	260	215	240	320
100/4 C5	835	480	230	195	240	320

		55/2 B2	55/4 B6	55/4 C2	55/4 C5
	[kg]	88	111	125	119
	PN 6 /10	DN 80	DN 100	DN 150	DN 100
	[mm]	70	70	100	100
	S2	32 min.	14 min.	14 min	14 min.
	S3*	40 %	20 %	20 %	20 %
EX		D 112-2/110	D 112-4/110	D 112-4/110	D 112-4/110
Motor	PTB 08	08 ATEX 1115 X	ATEX 1115 X	ATEX 1115 X	ATEX 1115 X
	 II 2 G	Ex db IIB T4 Gb	Ex db IIB T4 Gb	Ex db IIB T4 Gb	Ex db IIB T4 Gb
P1 / P2	[kW]	5,2 / 4,5	5,8 / 4,7	5,8 / 4,7	5,8 / 4,7
U	[V]	3/PE ~400/690	3/PE ~400/690	3/PE ~400/690	3/PE ~400/690
f	[Hz]	50	50	50	50
I	[A]	8,7 / 5,0	10,2 / 5,9	10,2 / 5,9	10,2 / 5,9
Ader	∅	10G2,5	10G2,5	10G2,5	10G2,5
cos phi		0,87	0,83	0,83	0,83
n	[min ⁻¹]	2910	1430	1430	1430

		75/2 B5	75/4 B6	75/4 C2	75/4 C5
	[kg]	98	116	131	124
	PN 6 /10	DN 80	DN 100	DN 150	DN 100
	[mm]	70	70	100	100
	S2	27 min.	18 min.	18 min.	18 min.
	S3*	30 %	25 %	25 %	25 %
EX		D 112-2/140	D 112-4/140	D 112-4/140	D 112-4/140
Motor	PTB 08	ATEX 1115 X	ATEX 1115 X	ATEX 1115 X	ATEX 1115 X
	 II 2 G	Ex db IIB T4 Gb	Ex db IIB T4 Gb	Ex db IIB T4 Gb	Ex db IIB T4 Gb
P1 / P2	[kW]	7,7 / 6,6	7,2 / 5,9	7,2 / 5,9	7,2 / 5,9
U	[V]	3/PE ~400 / 690	3/PE ~400 / 690	3/PE ~400 / 690	3/PE ~400 / 690
f	[Hz]	50	50	50	50
I	[A]	13,2 / 7,7	12,8 / 7,4	12,8 / 7,4	12,8 / 7,4
ADER	∅	10G2,5	10G2,5	10G2,5	10G2,5
cos phi		0,84	0,81	0,81	0,81
n	[min ⁻¹]	2925	1432	1432	1432

		100/2 B5	100/4 C2	100/4 C5
	[kg]	121	149	138
	PN 6 /10	DN 80	DN 150	DN 100
	[mm]	70	100	100
	S2	29 min.	27 min.	27 min.
	S3*	30 %	25 %	25 %
EX		D 112-2/200	D 112-4/200	D 112-4/200
Motor	PTB 08	ATEX 1115 X	ATEX 1115 X	ATEX 1115 X
	 II 2 G	Ex db IIB T4 Gb	Ex db IIB T4 Gb	Ex db IIB T4 Gb
P1 / P2	[kW]	10,5 / 9,2	9,5 / 8,0	9,5 / 8,0
U	[V]	3/PE ~400 / 690	3/PE ~400 / 690	3/PE ~400 / 690
f	[Hz]	50	50	50
I	[A]	17,6 / 10,2	17,2 / 10,0	17,2 / 10,0
ADER	∅	10G2,5	10G2,5	10G2,5
cos phi		0,86	0,81	0,81
n	[min ⁻¹]	2920	1444	1444

		35 B6	55/2 B2	55/4 B6
	[kg]	114	88	130
	PN 6 /10	DN 100	DN 80	DN 100
	[mm]	70	70	70
	S2	18 min	35 min	25 min
	S3*	25 %	35 %	20 %
Motor		D112-4/140 D	D112-2/140 D	D112-4/200 B
P1 / P2	[kW]	7,2 / 6,2	8,3 / 7,1	10,5 / 9,0
U	[V]	3/PE x 460/795	3/PE x 460/795	3/PE x 460/795
f	[Hz]	60	60	60
I	[A]	11,0 / 6,4	12,6 / 7,3	16,0 / 9,2
ADER	∅	6G1,5	10G2,5	10G2,5
cos phi		0,83	0,82	0,81
n	[min ⁻¹]	1750	3500	1750

* Beispiel: 40%: 4 min Betrieb + 6 min Pause (Spieldauer 10 min)

* Example for 40%: 4 min. operation and 6 min. rest (Cycle duration 10 min.)

* Exemple: 40% = 4 min de service et 6 min de pause (Durée du jeu 10 min)

* Eksempel: 40 %: 4 min drift + 6 min pause (spilletid 10 min)

* Exemplo para 40%: 4 min. operação e 6 min. pausa (duração de ciclo 10 min.)

* Esempio: 40%: 4 min. di funzionamento + 6 min. di pausa (durata del ciclo 10 min.)

* Przykładowo 40%: 4 min pracy i 6 min przerwy (Czas cyklu 10 min)

* Příklad 40%: 4 min. provoz a 6 min. přestávka (trvání pracovního cyklu 10 min.)

* Příklad 40%: 4 min prevádzka a 6 min prestávka (doba trvania cyklu 10 min)

* 4 perc üzem és 6 perc szünet (ciklusidő 10 perc)

* Exemplu 40%: 4 min funcționare și 6 min pauză (timp aproximativ 10 min)

**LEISTUNGEN • PERFORMANCE • PUISSANCES • PRESTAZIONI • WYDAJNOŚCI I MOCE •
VÝKONY • TELJESÍTMÉNY • CAPACITĂȚI**

H[m]	1	2	3	4	5	6	7	8	9	12	15	18	21	24	27	30	33	36
	Q [m³/h]																	
55/2 B2	127	123	118	114	109	103	97	91	85	65	44	24	6					
55/4 B6	167	160	154	147	140	132	123	114	103	72	39	12						
55/4 C2	245	229	214	198	184	164	144	125	105	41								
55/4 C5	198	190	181	172	161	149	136	125	112	74	32							
75/2 B5	150	147	142	135	131	126	121	116	110	93	77	59	42	27	15			
75/4 B6	191	188	181	173	165	157	150	141	131	104	72	41	17					
75/4 C2	270	257	245	233	216	199	185	168	146	86	26							
75/4 C5	212	204	195	187	178	169	160	148	138	99	61	22						
100/2 B5	190	188	184	182	177	174	169	164	159	144	129	113	97	79	63	47	32	18
100/4 C2	300	287	278	268	259	243	230	217	203	149	95	46						
100/4 C5	260	255	249	238	229	219	208	195	180	142	102	65	28					
35/46 B6	189	185	180	174	167	161	153	144	135	108	79	50	23	7				
55/26 B2	149	148	146	143	140	137	133	129	124	111	95	80	64	45	30	19		
55/46 B6	210	202	196	192	188	184	177	172	166	141	113	84	58	32	15			
UC 55/2 B2						103	97	91	85	65	44	24	6					
UC 55/4 C5										74	32							
UC 75/2 B5										93	77	59	42	27	15			
UC 75/4 B6										104	72	41	17					
UC 75/4 C5										99	61	22						
UC 100/2 B5													97	79	63	47	32	18

MULTISTREAM 55/2

Ersatzteile - Spare parts - Pièces de rechange - Reserveonderdelen - Parti di ricambio - Reservedele - Reservdelar
 Varaosat - Części zamienne - Náhradní díly - Alkatrészek - Piese de schimb - Запасные части - 备件

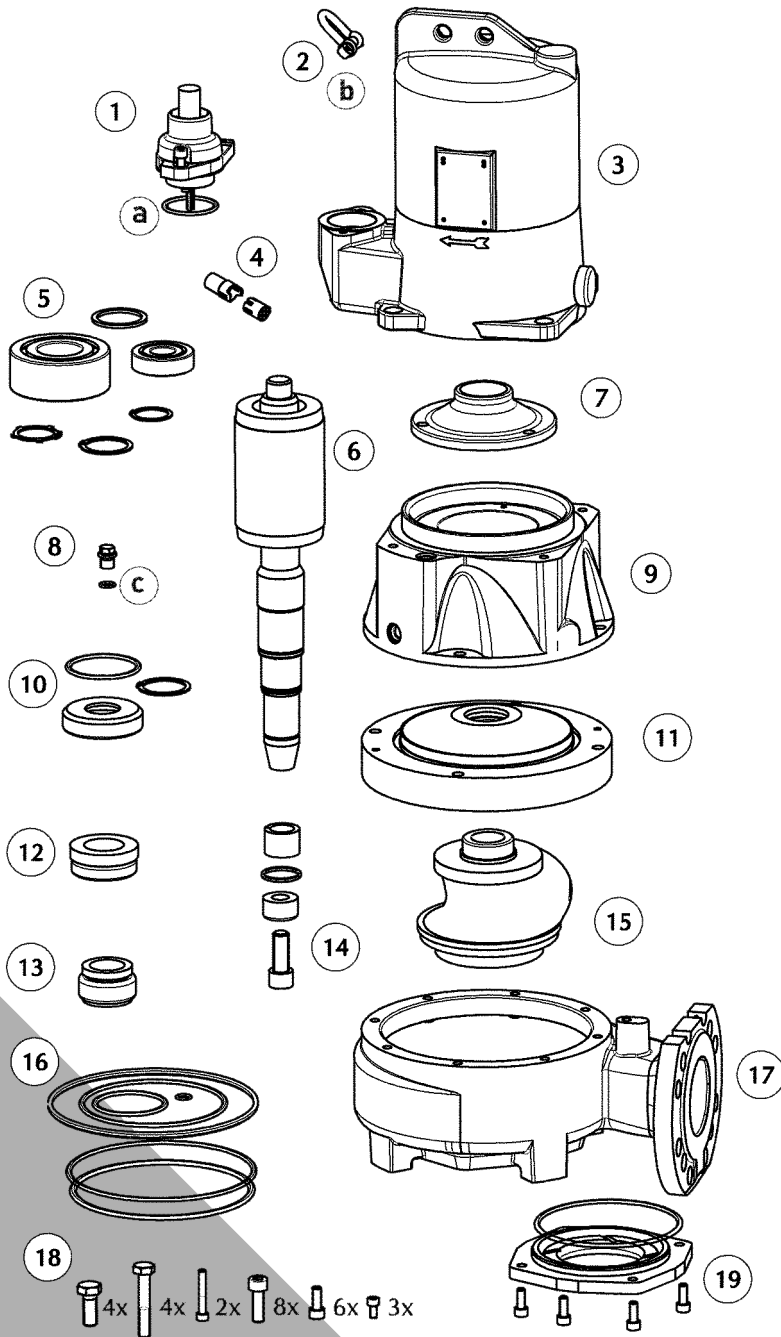

①	Leitung	Cable	
	10 m		JP46575
	EX, 10 m		JP46576
	EX, 15 m		JP46634
	EX, 20 m		JP46635
	EX, 25 m		JP46636
	EX, 30 m		JP46637
②	Schäkel	Shackle	JP45904
③	Stator + Gehäuse	Stator + Housing	JP47141
④	Steckverbinder	Connector	JP46573
⑤	Lagersatz	Bearing set	JP47137
⑥	Rotorwelle	Rotor shaft	JP47148
⑦	Lagerdeckel	Bearing cover	JP47155
⑧	Ölschraube	Oil screw	JP46046
⑨	Lagerkammer	Bearing housing	JP47162
⑩	Wellenabdeckung	Shaft cover	JP47181
⑪	Trennflansch	Partition flange	JP47160
⑫	Gleitringdichtung	Mechanical seal	JP46587
⑬	Gleitringdichtung	Mechanical seal	JP47140
⑭	Lauf radbefestigung	Impeller fixation	JP47182
⑮	Lauf rad	Impeller	JP47145
⑯	Dichtungssatz	Seal set	JP47138
⑰	Pumpengehäuse	Pump casing	JP47063
⑱	Schraubensatz	Screw set	JP47139
⑲	Schleifring	Wear ring	JP47163
⑳	1l Öl	1l Oil	JP48236

a	10x O-Ring 47x3,5	JP48110
b	10x Splint / Cotter pins 1,6 x 20	JP46182
c	10x O-Ring 10x2,5	JP48088

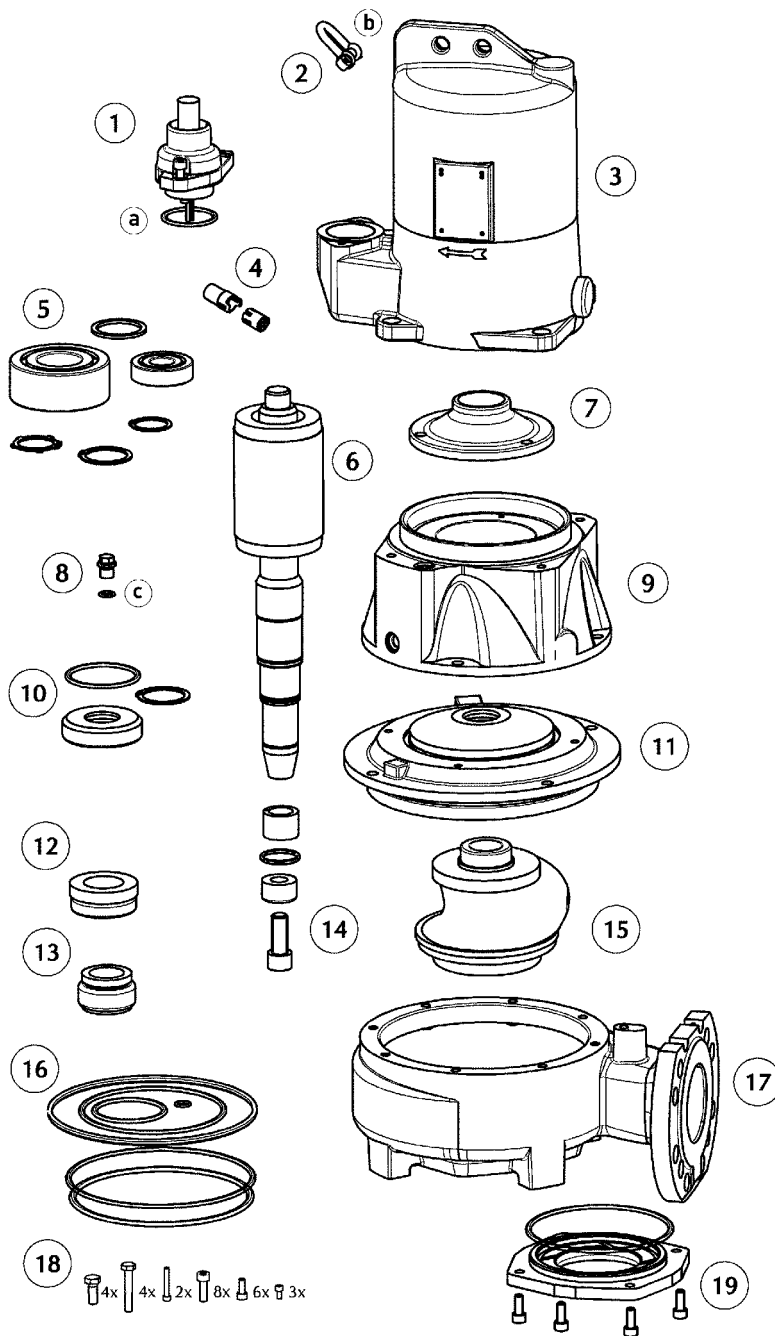

a	10x O-Ring 47x3,5	JP48110
b	10x Splint / Cotter pins 1,6 x 20	JP46182
c	10x O-Ring 10x2,5	JP48088

①	Leitung 10 m EX, 10 m EX, 15 m EX, 20 m EX, 25 m EX, 30 m	Cable	JP46575 JP46576 JP46634 JP46635 JP46636 JP46637
②	Schäkel	Shackle	JP45904
③	Stator + Gehäuse 55/4 75/2 75/4 100/2 100/4	Stator + Housing	JP47142 JP46574 JP47143 JP47144 JP47178
④	Steckverbinder	Connector	JP46573
⑤	Lagersatz	Bearing set	JP47137
⑥	Rotorwelle 55/4 75/2 75/4, 76/4 100/2 100/4	Rotor shaft	JP47151 JP47149 JP47152 JP47150 JP47169
⑦	Lagerdeckel	Bearing cover	JP47155
⑧	Ölschraube	Oil screw	JP46046
⑨	Lagerkammer	Bearing housing	JP47158
⑩	Wellenabdeckung	Shaft cover	JP47181
⑪	Trennflansch B5 B6, C2, C5	Partition flange	JP47159 JP47161
⑫	Gleitringdichtung	Mechanical seal	JP46587
⑬	Gleitringdichtung	Mechanical seal	JP47140
⑭	Laufradbefestigung B5, C5, 55/4 C2 B6, 75/4, 100/4 C2	Impeller fixation	JP47182 JP47183
⑮	Laufrad 55/4 B6 55/4 C2 55/4 C5 75/2 B5 75/4 B6 75/4 C2 75/4 C5 100/2 B5 76/4 C5, 100/4 C2, 100/4 C5	Impeller	JP47156 JP47172 JP47170 JP47146 JP47157 JP47173 JP47171 JP47147 JP47174
⑯	Dichtungssatz	Seal set	JP47138
⑰	Pumpengehäuse B5 B6 C2 C5 UC ...C5 UC ...B6	Pump casing	JP47153 JP47101 JP47175 JP47176 JP47177 JP47154
⑱	Schraubensatz	Screw set	JP47139
⑲	SchleiBring 55/4 B6 55/4 C2 55/4 C5, 75/4 C5 75/2 B5 75/4 B6 75/4 C2, 76/4 C5, 100/4 C2, 100/4 C5 100/2 B5	Wear ring	JP47164 JP47167 JP47166 JP47072 JP47165 JP47168 JP47163
⑳	1l Öl	1l Oil	JP48236



**PUMP TECHNICAL
SERVICES LIMITED**



THE SUBMERSIBLE PUMP SPECIALISTS

✉ service@pts-jung.co.uk

✉ sales@pts-jung.co.uk

Pump House
Unit 12
Bilton Road Industrial Estate
Erith, Kent, DA8 2AN

☎ 01322 357 080

🌐 pts-jung.co.uk