



**PUMP TECHNICAL
SERVICES LIMITED**



THE SUBMERSIBLE PUMP SPECIALISTS

MANUFACTURING | SALES | PROJECT DESIGN | INSTALLATION | MAINTENANCE AND REPAIRS

U5 - U6



U5 K U6 KE U6 KD
U5 KS U6 KES U6 KDS

EN Instruction Manual



Type Tested
and Monitored

www.tuv.com
ID 1111219532

 service@pts-jung.co.uk
 sales@pts-jung.co.uk

Pump House
Unit 12
Bilton Road Industrial Estate
Erith, Kent, DA8 2AN

 01322 357 080

 pts-jung.co.uk

You have purchased a product made by JUNG PUMPEN and with it, therefore, also excellent quality and service. Secure this service by carrying out the installation works in accordance with the instructions, so that our product can perform its task to your complete satisfaction. Please remember that damage caused by incorrect installation or handling will adversely affect the guarantee. Therefore please adhere to the instructions in this manual!

This appliance can be used by children aged 8 years or over and by persons with limited physical, sensory or intellectual capabilities, or with limited experience and knowledge, provided that they are supervised or have been instructed in the safe use of the appliance and are aware of the dangers involved. Children must not be allowed to play with the appliance. Cleaning and user maintenance must not be carried out by children unless they are supervised.

Damage prevention in case of failure

Like any other electrical device, this product may fail due to a lack of mains voltage or a technical defect.

If damage (including consequential damage) can occur as a result of product failure, the following precautions can be taken at your discretion:

- Installation of a water level dependent (under circumstances, mains-independent) alarm system, so that the alarm can be heard before damage occurs.
- Inspection of the collecting tank/chamber for tightness up to the top edge before – or at the latest, during – installation or operation of the product.
- Installation of backflow protection for drainage units that can be damaged by wastewater leakage upon product failure.
- Installation of a further product that can compensate in case of failure of the other product (e.g. duplex unit).
- Installation of an emergency power generator.

As these precautions serve to prevent or minimise consequential damage upon product failure, they are to be strictly observed as the manufacturer's guideline – in line with the standard DIN EN specifications as state of the art – when using the product (Higher Regional Court Frankfurt/Main, Ref.: 2 U 205/11, 06/15/2012).

SAFETY INSTRUCTIONS

This instruction manual contains essential information that must be observed during installation, operation and servicing. It is therefore important that the installer and the responsible technician/operator read this instruction manual before the equipment is installed and put into operation. The manual must always be available at the location where the pump or the plant is installed.

Failure to observe the safety instructions can lead to the loss of all indemnity.

In this instruction manual, safety information is distinctly labelled with particular symbols. Disregarding this information can be dangerous.



General danger to people



Warning of electrical voltage

NOTICE! Danger to equipment and operation

Qualification and training of personnel

All personnel involved with the operation, servicing, inspection and installation of the equipment must be suitably qualified for this work and must have studied the instruction manual in depth to ensure that they are sufficiently conversant with its contents. The supervision, competence and areas of responsibility of the personnel must be precisely regulated by the

operator. If the personnel do not have the necessary skills, they must be instructed and trained accordingly.

Safety-conscious working

The safety instructions in this instruction manual, the existing national regulations regarding accident prevention, and any internal working, operating and safety regulations must be adhered to.

Safety instructions for the operator/user

All legal regulations, local directives and safety regulations must be adhered to.

The possibility of danger due to electrical energy must be prevented.

Leakages of dangerous (e.g. explosive, toxic, hot) substances must be discharged such that no danger to people or the environment occurs. Legal regulations must be observed.

Safety instructions for installation, inspection and maintenance works

As a basic principle, works may only be carried out to the equipment when it is shut down. Pumps or plant that convey harmful substances must be decontaminated.

All safety and protection components must be re-fitted and/or made operational immediately after the works have been completed. Their effectiveness must be checked before restarting, taking into account the current regulations and stipulations.

Unauthorised modifications, manufacture of spare parts

The equipment may only be modified or altered in agreement with the manufacturer. The use of original spare parts and accessories approved by the manufacturer is important for safety reasons. The use of other parts can result in liability for consequential damage being rescinded.

Unauthorised operating methods

The operational safety of the supplied equipment is only guaranteed if the equipment is used for its intended purpose. The limiting values given in the "Technical Data" section may not be exceeded under any circumstances.

Instructions regarding accident prevention

Before commencing servicing or maintenance works, cordon off the working area and check that the lifting gear is in perfect condition.

Never work alone. Always wear a hard hat, safety glasses and safety shoes and, if necessary, a suitable safety belt.

Before carrying out welding works or using electrical devices, check to ensure there is no danger of explosion.

People working in wastewater systems must be vaccinated against the pathogens that may be found there. For the sake of your health, be sure to pay meticulous attention to cleanliness wherever you are working.

Make sure that there are no toxic gases in the working area.

Observe the health and safety at work regulations and make sure that a first-aid kit is to hand.

In some cases, the pump and the pumping medium may be hot and could cause burns.

For installations in areas subject to explosion hazards, special regulations apply!

APPLICATION



WARNING!

The pump must only be connected to sockets that have been installed properly in accordance with the regulations and are protected with at least 10 A (slow) and RCD-safety switches (30mA).



DANGER!

The pump must never be used when a person is in the water.

Submersible pumps from the U5 and U6 series are suitable for pumping domestic waste water without stones. This includes also water from household dishwashers and household washing machines.

The U6 can also pump ground water, drainage silage liquor and liquid manure.

NOTICE! In outdoor applications, only pumps with at least a 10-metre mains cable must be used.

When using the pumps, the relevant national laws, regulations and stipulations must be adhered to, for example:

- Domestic contaminated and waste water (e.g. EN 12056 in Europe)
- Installation of low voltage systems (e.g., VDE 0100 in Germany)

For non-standard utilization conditions, further regulations must be observed (e.g. VDE 0100 in Germany, part 701: bathrooms and shower rooms; part 702: swimming pools and fountains and part 737: outdoor use).

Temperatures

The pumped medium must have a temperature of max 35°C.

The submersible pump is frost-resistant down to -20°C when stored in dry conditions. When installed, however, it must not be allowed to freeze in the water.

Transport

The pump must always be lifted by the handle and never by the power supply cable! The pump should only be lowered into deeper chambers or pits using a rope or chain.

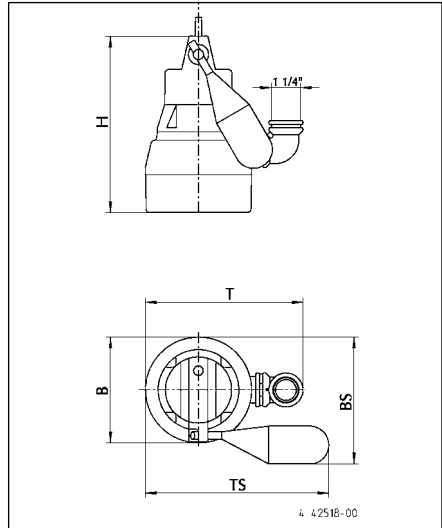

Dimensions [mm]

	H	B	T	BS	TS
U5 K	280	170	250	205	290
U6 K	335	175	255	210	295

Pumps with special float assembly, (JP44207)

	H	BS	TS
U5 KS	280	245	285
U6 KS	335	250	290

Switching points On - Off for built-in switching

	Normal		Special	
	●	○	●	○
U5 KS	240	135	-	-
U6 KS	270	170	-	-

ELECTRICAL CONNECTION

NOTICE! Only qualified electricians may carry out electrical works to the pump or the controls.



WARNING!

Before carrying out any works: disconnect the pump and the controls from the mains and take steps to ensure that no one else can reconnect them to the power supply.

The relevant standards (such as EN standards), country-specific regulations (such as VDE in Germany), and the regulations of the local power supply companies must be observed.

NOTICE! Never put the mains plug or a free lead end in water! If water gets into the plug, this can cause malfunctions and damage.

Observe the operating voltage (see the type plate)!

The pump is provided with a winding thermostat. In case of unacceptably high temperatures it switches off the pump to protect it against possible damage. Unacceptably high temperatures may result e.g. from dry running or mechanical or electrical overload.



CAUTION!

The pump is switched on again automatically after cooling down - risk of injury!

For this reason, always disconnect the device from the mains before remedying the fault! In order to do this, unplug from the mains supply or remove the pre-fuses of the pump controls!

Rotational direction

Applies only for three-phase pumps. The rotational direction must be checked before installation! If the rotational direction is correct, the start-up jolt should be counter-clockwise. If the rotational direction is wrong, 2 phases of the supply cable must be swapped over, because a wrong direction of rotation results in an overload of the pump.

Alternating and three-phase current circuit diagrams

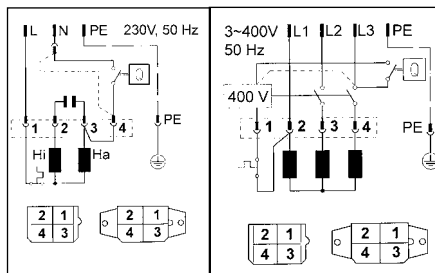

INSTALLATION

The pump must be installed as shown in the examples. For installations in accordance with EN 12056-4, the pressure pipe must be laid in a loop above the local backflow level and protected with a backflow prevention valve. The rubber flap supplied (U5) is for mobile operation only.

A correspondingly larger diameter pipe should be used for longer pressure pipelines to avoid pipe friction losses.

With any pump that has no automatic switching, the switch-on and switch-off heights can be set variably with a separate level control. Our ready to connect level controls can be installed without specific electrotechnical skills.

The pump housing is automatically vented using the enclosed bracket. If this is not required, the vent opening can be closed, such as for mobile operation.

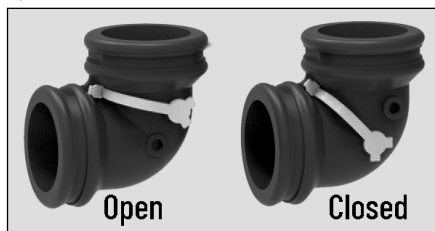

Dimensions of chamber

Single installation with pump base: 40 x 40 cm
 Single installation with guide rail system:
 40 x 50 cm and Duplex installation: 50 x 50 cm

Example of installation with guide rail system

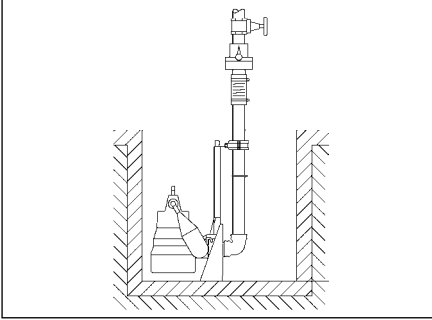

Installation

Fix the coupling base firmly to the floor of the collection chamber using wall plugs and then mount the guide rail. Next, install the pressure pipe including the necessary fittings, such as the non-return valve and shut-off valves.

Reseal the coupling catch at the pump and tighten it until it is "hand tight". Finally, fit the pump with the coupling catch onto the guide rail and lower it into place using a chain fixed to the handle.

Example of installation Duplex unit

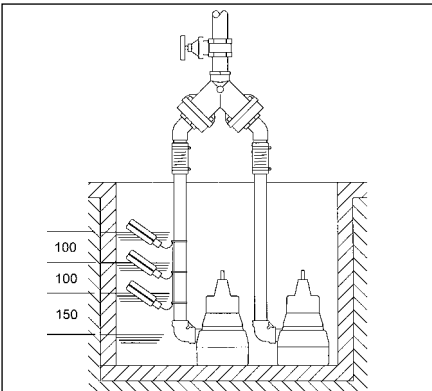

NOTICE! The floats of the level controller and alarm system are installed so that they are freely movable but not under the inlet. Please observe the minimum distances. The controls may only be installed in a dry and well ventilated room!

Flushing device

The pump can keep the intake section at the bottom of the chamber clear of deposits to a large extent if you carry out a small modification. This reduces the performance of the pump only insignificantly.

This modification is carried out as follows. Detach the foot strainer and carefully drill a hole into the 3 markings with the $\varnothing 5$ symbols. Deburr the drillholes. When reattaching the foot strainer, ensure that the new drill-holes are not covered by the bars of the foot strainer. The U5 and U6 ranges provide markings on the housing and the foot strainer to help you.

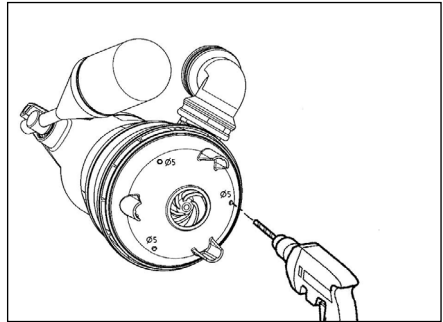

Low level pumping

Flooded areas can be pumped out leaving only few mm of residual water without the need for optional extras, U5K: 6 mm and U6K: 10 mm. To do so, the foot strainer must be levered off with a screwdriver. In the case of pumps with an attached control, the float switch must be locked in the ON position. It is not possible therefore in low level pumping to operate the pump in switching mode.

To make the pump operate, the drainage hose must be emptied before each pumping run and there must be a minimum water level available of, for U5K: 60 mm and for U6K: 90 mm.

⚠ CAUTION!

For safety reasons, mobile operation is only allowed vertically and with a foot strainer!

If a hose is used as a pressure line, care must be taken to ensure that for every pumping operation the hose is completely empty before the pump is submersed. Any residual liquid would obstruct the ventilation of the pump housing and therefore also hinder the pumping operation. For the same reason, the pump would not operate if it was switched on before being submersed.

The enclosed rubber flap (not Flutbox and U6) is fitted in the attached elbow (U5). Ensure that the flap opens in the direction of flow.

Enlarging the free passage

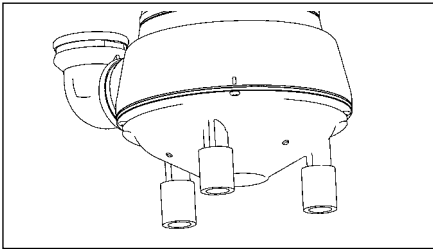

The free passage of the U5 and U6 pump ranges can be enlarged from 10 to 20 mm. This is done by levering off the foot strainer and attaching the enclosed extensions to the integrally molded pump feet. The foot strainer no longer fits under the pump.

NOTICE! If the pump is malfunctioning, part of the contents of the oil reservoir could escape into the pumping medium.

MAINTENANCE

Maintenance and inspection of this product must be carried out in accordance with EN 12056-4.

⚡ WARNING!

Before carrying out any works: disconnect the pump and the controls from the mains and take steps to ensure that no one else can reconnect them to the power supply.

⚡ WARNING!

Check the mains cable for signs of mechanical and chemical damage. Damaged or kinked cables must be replaced by the manufacturer.

NOTICE! If the water contains high levels of iron or lime, insufficient cleaning can result in irreparable damage to the seal and thus also to the pump motor in the long term.

Consequently, the pump must be cleaned at regular intervals according to the hardness of the water.

Cleaning

The foot strainer prevents coarse impurities from entering the pump. Regular cleaning of the float and the foot strainer ensures optimum performance and operation.

Cleaning of the impeller U5 and U6

To clean the impeller, and in the event of an obstacle or blockage, the foot strainer must be levered off. After this, take out the screws on the underside of the pump and remove the cover. The impeller can now be cleaned.

⚠ CAUTION!

Worn impellers can have sharp edges.

If the pump performance decreases, the impeller must be checked for wear and replaced only by the manufacturer if necessary.

Tightening torque M_A for A2 screw materials

for M 5 $M_A = 5 \text{ Nm}$

for Amtec 3,5 $M_A = 1 \text{ Nm}$

for Amtec 5,0 $M_A = 2 \text{ Nm}$

QUICK TIPS FOR REMEDYING FAULTS

Pump does not work

- Check mains current (do not use a pin gauge)
- Fuse faulty = may be too weak (please refer to Electrical Connection)
- Mains supply cable damaged = repair to be carried out by manufacturer only

Pump runs but does not pump

- Empty the pressure pipe or hose to allow the non-return valve to open and the air to escape from the pump housing, it may be necessary to carry out a ventilation drilling

Impeller blocked

- Solids and fibrous matter have become lodged in the pump housing = clean

Decreased pumping performance

- Foot strainer obstructed = clean
- Pressure pipe obstructed = clean
- Rotor worn out = repair to be carried out by the manufacturer
- Wrong direction of rotation (for a three-phase current) = ask a qualified electrician to change 2 phases of the supply line

 0197	
JUNG PUMPEN GmbH - Industriestr. 4-6 33803 Steinhagen, Germany 20 401.17-22.02	
EN 12050-2:2001; 2015 Lifting plant for faecal-free wastewater DN 32	
U5 K (JP09386/0) U5 KS (JP09387/0) U5 KS (JP09417/0)	U6 K E (JP00226/2) U6 K D (JP00228/3) U6 K ES (JP00227/2) U6 K ES (JP09260/2) U6 K DS (JP00229/3) U6 K DS (JP09261/3)
Collecting and automatically lifting faecal-free waste water above the backflow level in buildings and sites	

REACTION TO FIRE	NPD
WATERTIGHTNESS	Pass
EFFECTIVENESS (LIFTING EFFECT)	
- Pumping of solids	Pass
- Pipe connections	Pass
- Ventilation	NPD
- Minimum flow velocity	Pass
- Minimum free passage of the plant	Pass
- Minimum useful volume	NPD
MECHANICAL RESISTANCE	
- Load bearing capacity and structural stability of collection tank for use	NPD
- Structural stability of collection tank for use inside buildings	NPD
NOISE LEVEL	70 dB(A)
DURABILITY	
- of structural stability	NPD
- of lifting effectiveness	Pass
- of mechanical resistance	NPD
DANGEROUS SUBSTANCES	NPD

DE - Technische Daten
 NL - Technische Gegevens
 CZ - Technické Údaje

EN - Technical Data
 IT - Dati Tecnici
 HU - Műszaki Adatok

FR - Caractéristiques Techniques
 PL - Dane Techniczne
 RO - Date Tehnice

	U5 K/KS	U6 KE/KES	U6 KD/KDS	U6 KES
[kg]	4,7 / 4,5	5,9 / 5,3	6,6 / 5,8	5,3
	DN	32	32	32
	[mm]	10 / 20	10 / 20	10 / 20
P1	[W] 520	750	750	750
P2	[W] 380	490	550	490
U	[V] 1/N/PE ~230	1/N/PE ~230	3/PE ~400	1/N/PEx230
f	[Hz] 50	50	50	60
I	[A] 2,3	3,3	1,3	3,3

DE - Leistungen
 NL - Capaciteit
 CZ - Výkony

EN - Performance
 IT - Prestazione
 HU - Teljesítmény

FR - Puissances
 PL - Wydajności i moce
 RO - Capacități

H[m]	1	2	3	4	5	6	7	8	9
	Q[m ³ /h]								
U5	11,5	10,5	9,0	7,5	6,5	4,5	2,5		
U6	15,5	14,5	13,0	11,5	9,5	8,0	6,0	4,0	1,5

Ersatzteile - Spare parts - Pièces de rechange - Reserveonderdelen - Parti di ricambio - Reservedele - Reservdelar
 Varaosat - Części zamienne - Náhradní díly - Alkatrészek - Piese de schimb - Запасные части - 备件

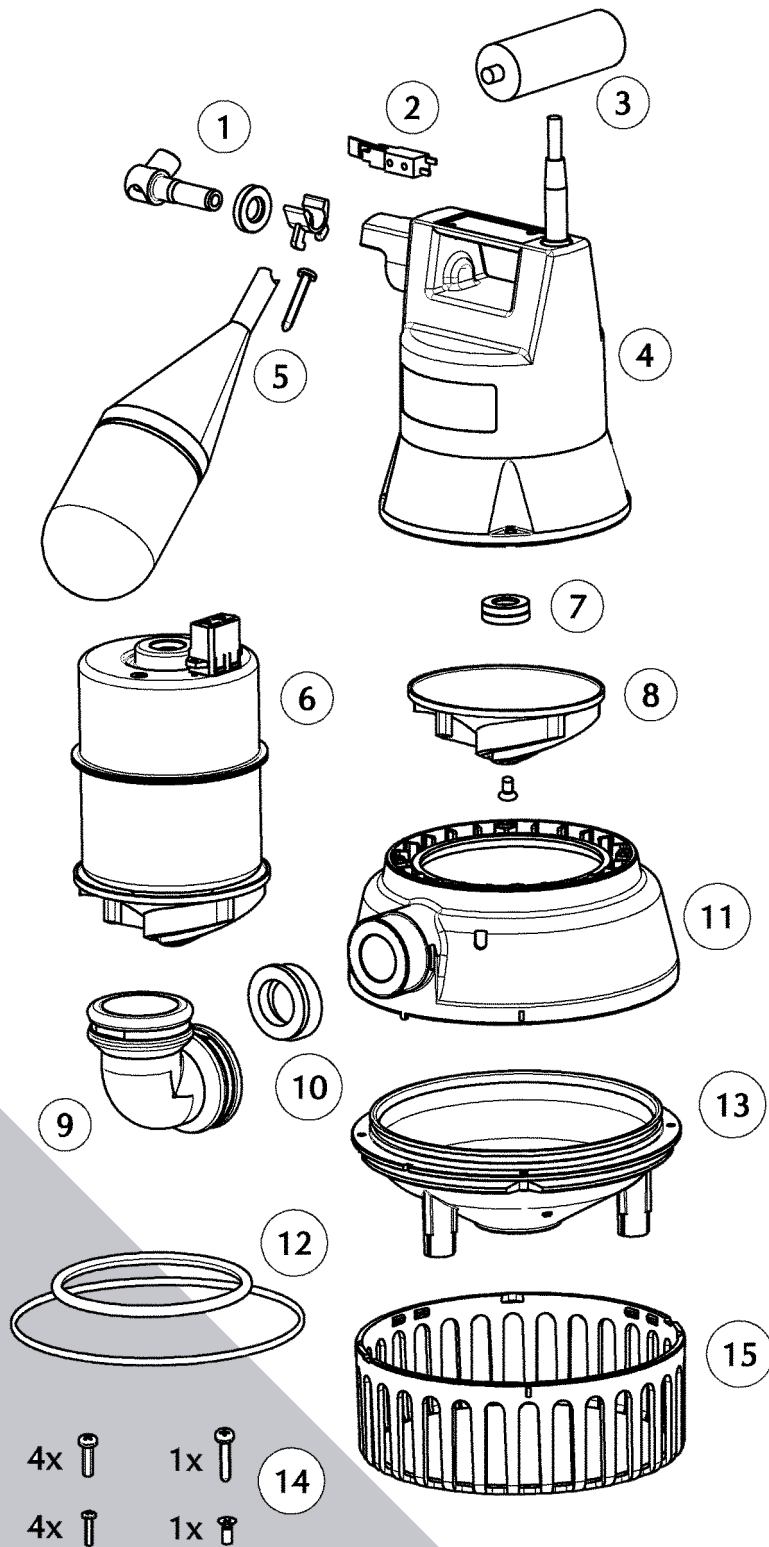

①	Schaltwelle	Shift shaft	JP42770
②	Mikroschalter	Microswitch	JP46351
③	Kondensator	Capacitor	JP46015
④	Anschlusseinheit	Top cover	
	U5 K, 10m		JP46389
	U5 KS, 4m		JP46390
	U5 KS, 10m		JP46391
⑤	Schwimmer	Float	JP42771
⑥	Motor	Motor	JP46388
⑦	Dichtungen	Seals	JP46385
⑧	Lauftrad	Impeller	JP46363
⑨	Winkel	Elbow	JP46355
⑩	Gummiklappe	Rubber flap	JP50774
⑪	Spiralgehäuse	Volute casing	JP46364
⑫	Dichtungssatz	Seal set	JP46354
⑬	Deckel	Cover	JP46387
⑭	Schraubensatz	Screw set	JP42773
⑮	Siebfuß	Strainer base	JP46365

Ersatzteile - Spare parts - Pièces de rechange - Reserveonderdelen - Parti di ricambio - Reservedele - Reservdelar
 Varaosat - Części zamienne - Náhradní díly - Alkatrészek - Piese de schimb - Запасные части - 备件

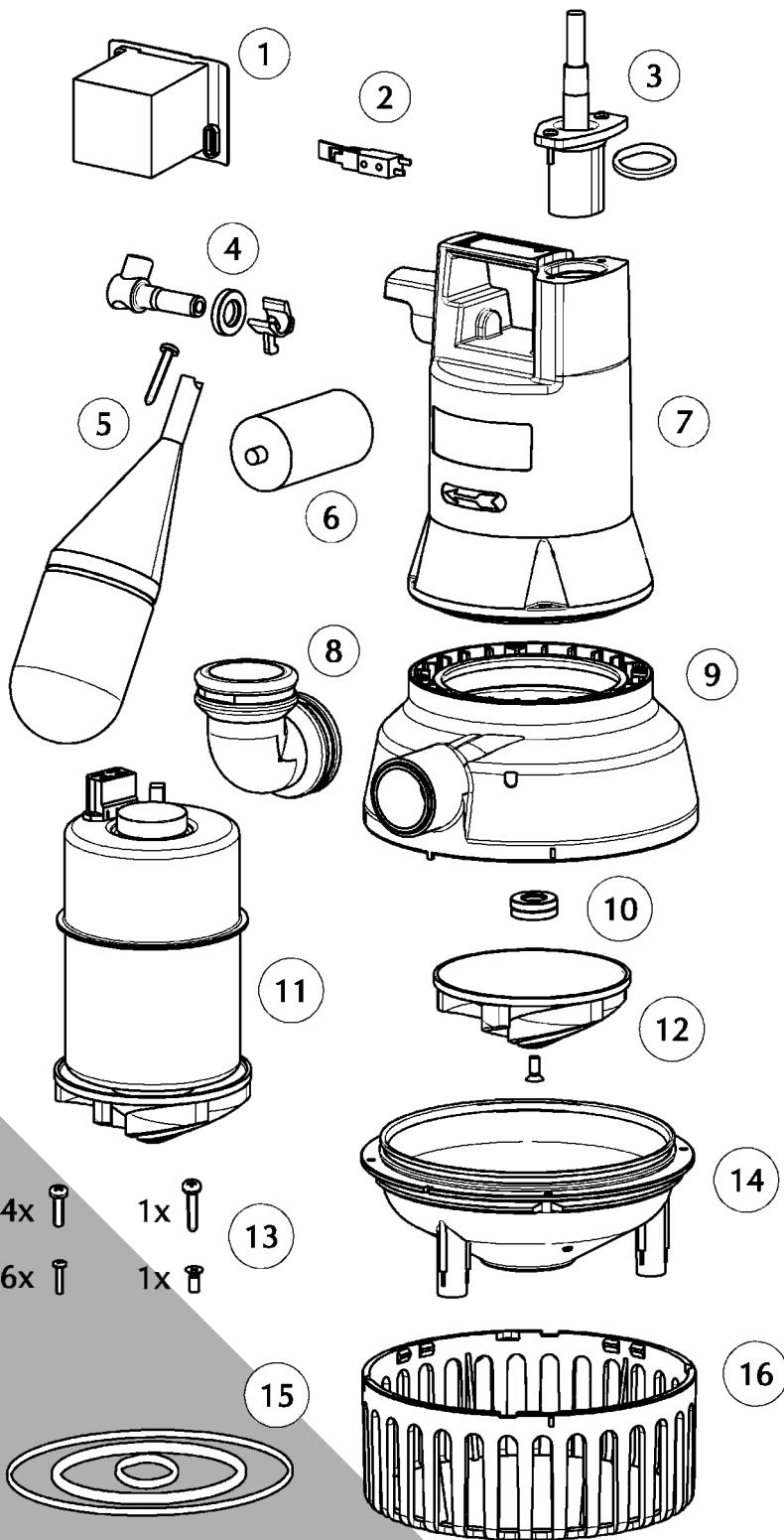

①	Schalterschütz	Motor contactor	JP46371	
②	Mikroschalter	Microswitch	JP46351	
			ES	JP46351
			DS	JP46352
③	Leitung	Cable	JP42776	
			E / ES, 4 m	JP42776
			E / ES, 10 m	JP42777
			D / DS, 4 m	JP42778
			D / DS, 10 m	JP42779
10 m, A/NZ-plug	JP47221			
④	Schaltwelle	Shift shaft	JP42770	
⑤	Schwimmer	Float	JP42771	
⑥	Kondensator	Capacitor	JP46374	
⑦	Haube	Top cover	JP46919	
			E	JP46919
			D	JP46920
			ES	JP46372
DS	JP46373			
⑧	Winkel	Elbow	JP46355	
⑨	Spiralgehäuse	Volute casing	JP46368	
⑩	Dichtungen	Seals	JP46370	
⑪	Motor	Motor	JP46375	
			E / ES	JP46375
D / DS	JP46376			
⑫	LaufRad	Impeller	JP46369	
⑬	Schraubensatz	Screw set	JP42773	
⑭	Deckel	Cover	JP42772	
⑮	Dichtungssatz	Seal set	JP46354	
⑯	Siebfuß	Strainer base	JP46367	



**PUMP TECHNICAL
SERVICES LIMITED**

**J JUNG
PUMPEN**

THE SUBMERSIBLE PUMP SPECIALISTS

✉ service@pts-jung.co.uk

✉ sales@pts-jung.co.uk

Pump House
Unit 12
Bilton Road Industrial Estate
Erith, Kent, DA8 2AN

☎ 01322 357 080

🌐 pts-jung.co.uk