

U6
DRAINAGE PUMPS

- Cooling jacket for motor housing
- Flushing device
- Low level pumping by detachable strainer base
- SiC mechanical seal independent of sense of rotation
- Safe to run dry
- 10/20 mm free passage with EIP technology
- Replaceable moisture sealed cable inlet



DESCRIPTION

The U6K range of pumps is suitable for stationary and portable use. It can be used as a drainage pump for mildly contaminated waste and ground water, in sumps with rain water, drainage or seepage water, silage liquor and also liquid manure. The high quality mechanical seal also makes the pump suitable for extracting abrasive media.

In stationary use the U6K ES/DS removes the waste water from domestic appliances such as dishwashers and washing machines (also high temperature). Guide rail systems offer the advantages of quick and easy maintenance. The Easyfix installation sets are particularly convenient. They are pre-assembled ready to plug in and can be installed as single or duplex systems. Our ready-to-install collecting tanks extend the options for installation and use.

For supporting sewage water with heavy pollution we recommend our US series. Especially for the transportable use, in building site areas for example, our building pumps MultiDrain UV should be used.

If centrifugal submersible pumps are used outdoors, only a pump with 10 m cable without extension cable may be used in accordance with VDE Regulation 0100.

PERFORMANCE

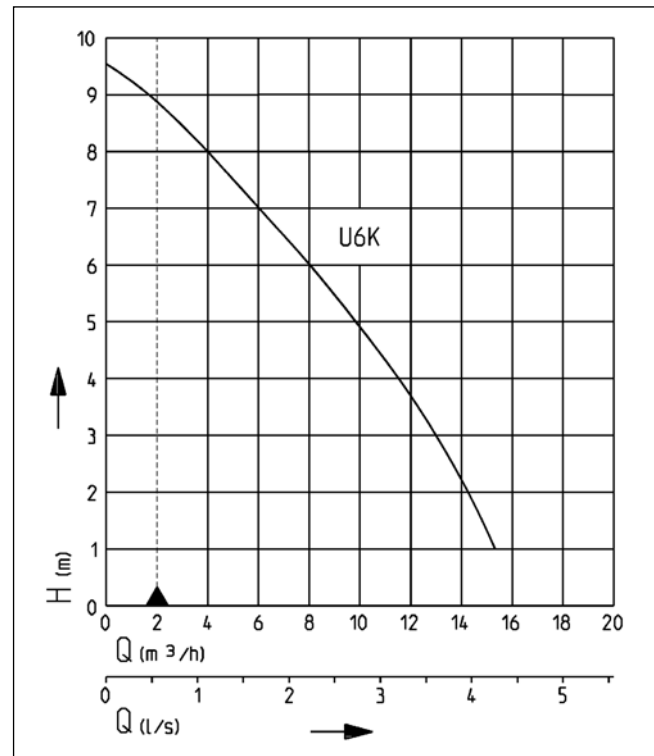

Type	Delivery head H [m]	1	2	3	4	5	6	7	8	9
U6K E/D/ES/DS	Flow rate Q [m³/h]	15.5	14.5	13.0	11.5	9.5	8.0	6.0	4.0	1.5

Specifications can be changed without notice. Performance subject to ISO 9906 tolerances. The minimum flow velocity in the pressure piping must be 0.7 m/s according to EN 12056. This data is represented in the performance curve as a limit of application.



U6

DRAINAGE PUMPS

SCOPE OF SUPPLY

Pump ready for connection acc. to EN 12050 with 90°, 1/4" female connection elbow, cable and plug, S model with automatic level float switch.

The pump is delivered with attached strainer base, which can be exchanged for the enclosed feet if 20 mm free passage is required.

MECHANICAL DATA

Pump	Vertical single-stage	Run dry protection	Yes
Free passage	20 mm	Shaft	Stainless steel
Bearing	Ball bearings, grease-lubricated	Impeller	Vortex impeller, GFK
Seal on motor side	Rotary shaft seal	Motor housing	Stainless steel
Oil chamber	Yes	Submersible	Yes
Seal on medium side	SiC mechanical seal	Pressure outlet	1 1/4"

ELECTRICAL DATA

Motor rating P1	0.75 kW	Winding thermostat	Yes
Type of enclosure	IP 68	Motor protection	Integrated
Insulation class	B		

U6

Type	Code No.	Voltage	Motor rating P2	Current	Power line	Wires	Plug	Weight
Without level control								
U6K E, 10 m cable	JP00226	1/N/PE~230 V	0.50 kW	3.3 A	10m H07RN-F	3G1,0	Safety	6.0 kg
U6K D, 10 m cable	JP00228	3/PE~400 V	0.55 kW	1.3 A	10m H07RN-F	4G1,0	CEE	6.5 kg
With built-in level control								
U6K ES, 4 m cable	JP00227	1/N/PE~230 V	0.50 kW	3.3 A	4m H07RN-F	3G1,0	Safety	5.5 kg
U6K DS, 4 m cable	JP00229	3/PE~400 V	0.55 kW	1.3 A	4m H07RN-F	4G1,0	CEE	5.9 kg
U6K ES, 10 m cable	JP09260	1/N/PE~230 V	0.50 kW	3.3 A	10m H07RN-F	3G1,0	Safety	6.2 kg
U6K DS, 10 m cable	JP09261	3/PE~400 V	0.55 kW	1.3 A	10m H07RN-F	4G1,0	CEE	6.8 kg

U6

DRAINAGE PUMPS

Dimensions and switching points U6KS (mm)

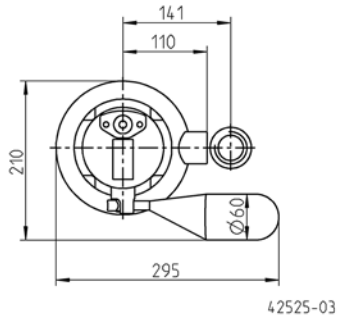
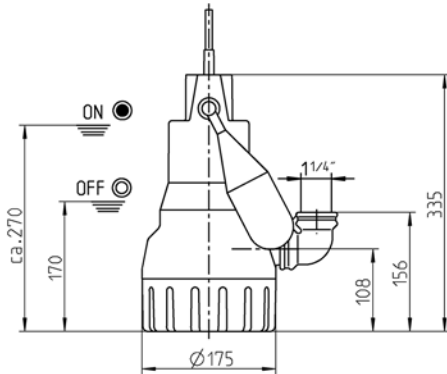

Dimensions and switching points special float (mm)

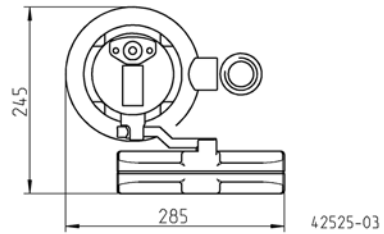
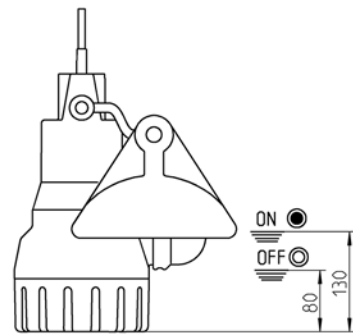

Dimensions and switching points special float (mm)

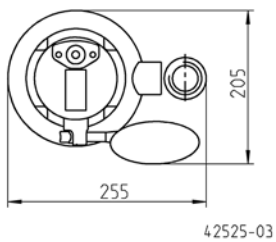
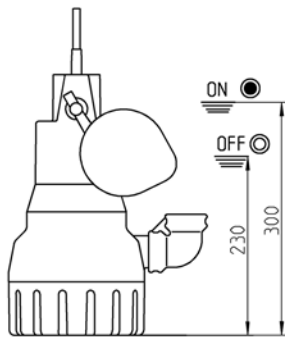

Dimensions and switching points GR 32 (mm)

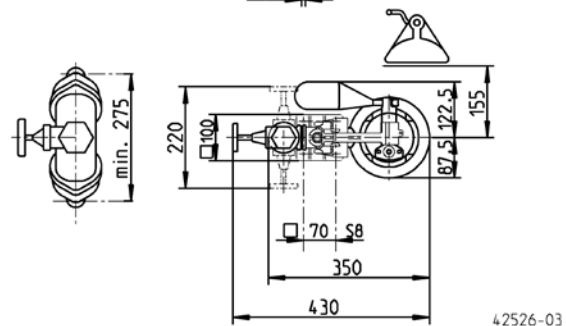
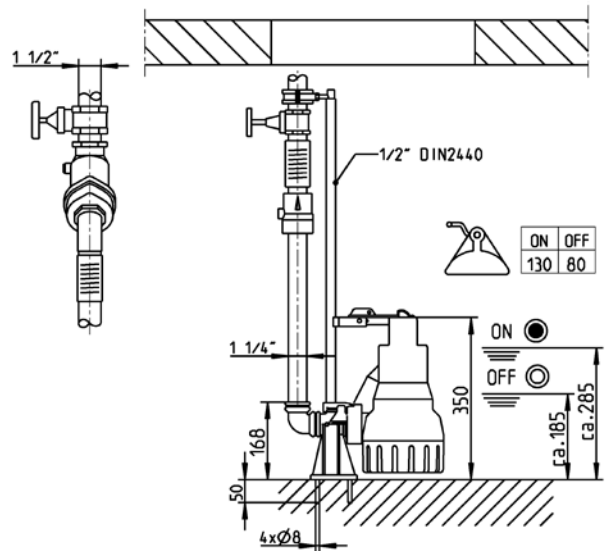

U6

DRAINAGE PUMPS

Example of single pump installation with GR

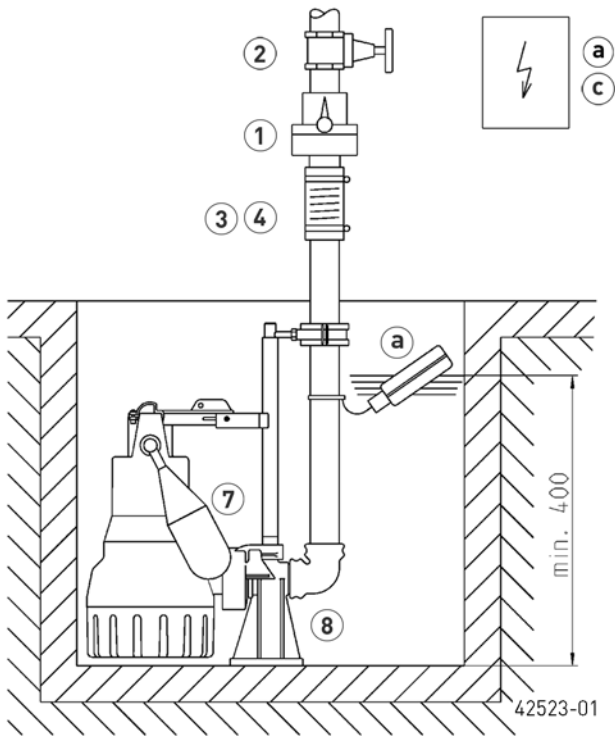

Example of duplex pump installation

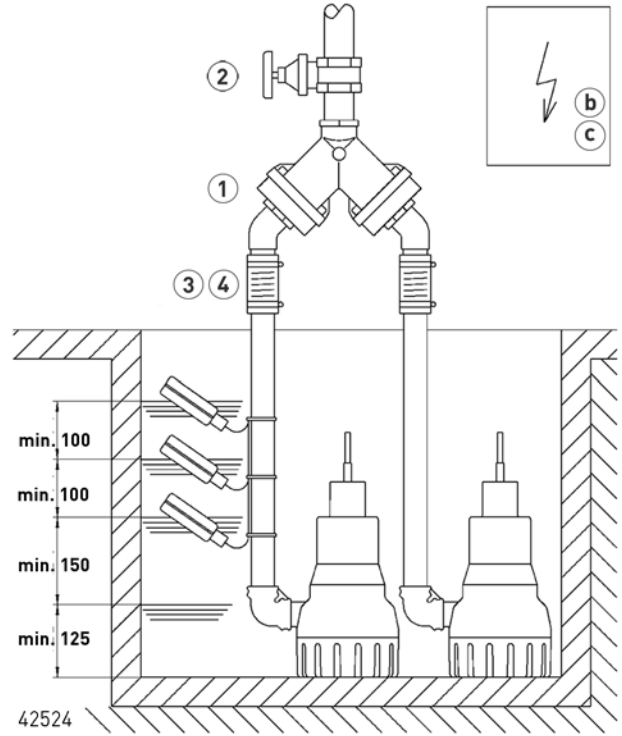

Example of installation and dimensions Easyfix 32 Single

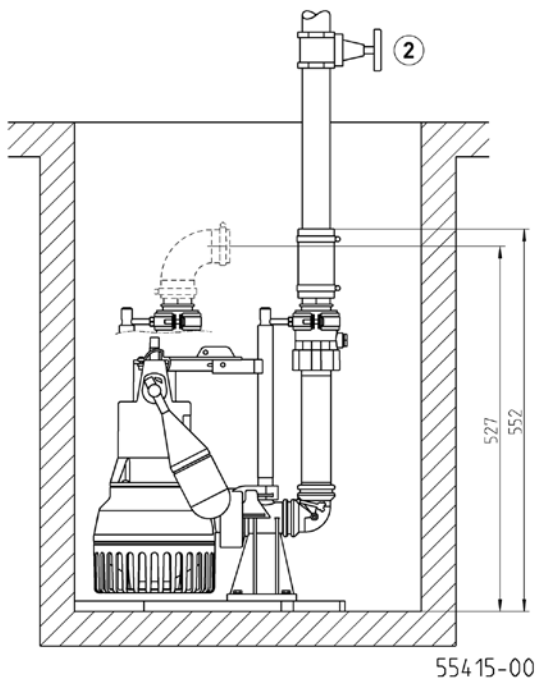

Example of installation and dimensions Easyfix 32 Duo

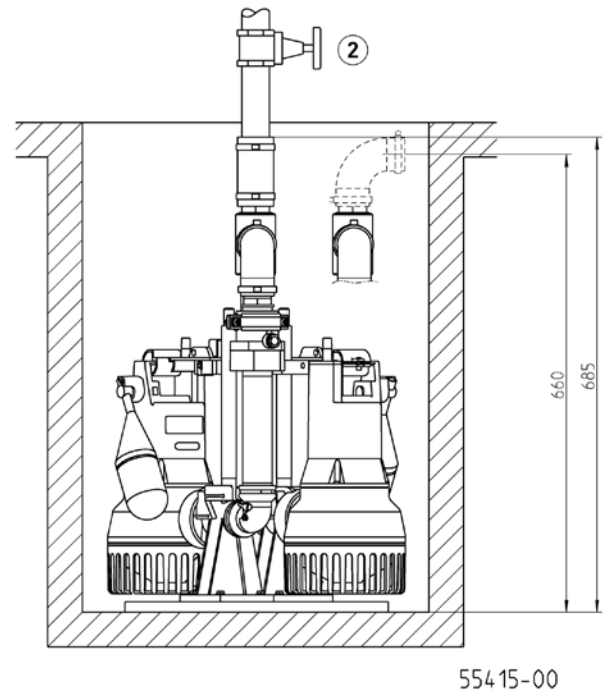













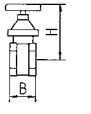

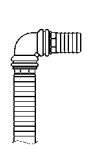

Single unit with GR: sump area min. 40x50 cm or Ø 50 cm
 Single unit without GR: sump area min. 40x40 cm or Ø 40 cm
 Duplex unit with GR: sump area min. 50x55 cm, Ø 65 cm
 Duplex unit without GR: sump area min. 50x50, Ø 55 cm
 Single unit Easyfix 32 Single: sump min. 30x45 cm, Ø 45 cm
 Duplex unit Easyfix 32 Duo: sump min. 50x40 cm, Ø 60 cm
 Duplex unit Easyfix 32 Duo with special float: sump min. 50x50 cm Ø 70 cm

In case of installation beneath the backpressure level the pressure tube must be taken in a loop over the local backup level acc. to EN 12056. Besides, it must be secured with an EN 12050-4-proofed swing-type check valve. Additionally we recommend an alarm system.
 In accordance with EN 12056-4 section 5.1, it has a built-in automatic spare pump or a double attachment included, which ensures that sewage drainage is not interrupted.
 Suspend control unit in a dry room

U6

DRAINAGE PUMPS



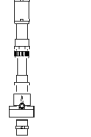

MECHANICAL ACCESSORY

					Code No.
	① Swing-type check valve				
	R32 EN 12050-4	1/4" (DN 32), PN 4	90x90 (HxB)		JP09739
	DR 40 EN 12050-4	1/2" (DN 40), PN 4	200x280 (HxB)		JP09155
	Rupper flap DN32	for transportable use	35x35 (HxB)		JP50774
	② Stop valve	1/4" (DN 32), PN 16	110x60 (HxB)		JP44785
		brass, 1/2" (DN 40), PN 16	125x60 (HxB)		JP44786
	③ Elastic connection	1/4" (DN 32), PN 3	100x42 (HxD)		JP44773
	④ Hose band clamp	1/4"			JP44765
	⑤ Hose coupling				
	Hose coupling	1/4" (DN 32) brass, for transportable use			JP00327
	Coupling Storz C	1 1/4" male thread			JP44780
	Coupling wrench				JP25708
	House connection	1/4" - 38/32/25			JP44209
	⑥ Hose set	1 1/4" (DN32), 15 m PVC hose c/w elbow			JP43550
	⑦ Special float	for lower switching points (U5 and U6)			JP44207
		for narrow chambers (mind. 30x30 od Ø30 cm)			JP40856
	Float fixation	for continuous pump operation			JP42175
	⑧ Guide rail system	GR 32			JP44000
	Support for guide rail extension	ex 2 m sump depth, per m 1 piece			JP28314
	Easyfix 32 Single	ready-to-connect installation set			JP50308
	Easyfix 32 Duo	ready-to-connect installation set with control unit for duplex units			JP50307
	⑨ Connection kit	DN 32, with telescopable pressure pipe 30-90 cm			JP44609

U6

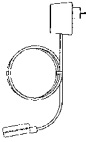
DRAINAGE PUMPS

ELECTRICAL ACCESSORY

			Code No.
	a Alarm unit		
	AG3	subm. ball contact switch, mains dependent, potential-free contact, 3 m cable	JP44891
	AG10	subm. ball contact switch, mains dependent, potential-free contact, 9.5 m cable	JP44892
	Washing machine stop		
	AW3	subm. ball contact switch, mains dependent, 3 m cable	JP44895
	b Control for duplex units		
	Control unit HIGHLOGO 2-00 E	230 V	JP47996
	Control unit BD 00 E	230 V, for pumps U3-U6, US 62-105, UV3, UV 300, 08/2 ME	JP45735
	Control unit HIGHLOGO 2-00	400 V	JP47997
	Control unit BD 00	400 V, for pumps U6, US 62-105, UV 300	JP45993
	Level control		
	Subm. switch pack B	3 subm. ball contact switch with 9.5 m and fixing devices	JP16725
	Subm. switch pack BmG	3 subm. ball contact switch with 9.5 m and counterweight	JP16726
	c Rechargeable battery	9 V, for mains independent alarm	JP44850
	d Smart Home	FTJP radio transmitter	JP47209