

US 62-US 251

SUBMERSIBLE DRAINAGE PUMPS

- 10 mm free passage
- Safe to run dry
- Controllable oil chamber
- SiC mechanical seal
- independent of sense of rotation
- Replaceable moisture sealed cable inlet



DESCRIPTION

The centrifugal submersible drainage pumps US 62-251 can be used wherever sewage water with solids up to 10 mm particle size occurs, e.g. in collecting sumps for ground water, or in permanent draining systems for clean water, or handling solids in suspension. They are also ideal for pumping the sewage water from collecting sumps into which dishwashers or washing machines are discharging. For high temperature hot water in the industrial and commercial field we recommend the use of our US 73 and US 103 HE/HES.

This range of pumps is suitable for stationary and portable use. For easy removal of the pumps from deep sumps we recommend the use of our guide rail systems which provide ease of maintenance and inspection.

For automatic monitoring of the oil chamber a seal leak control can be connected.

Maximum cable length of the pumps is 10 m. 3-phase pumps with level control (US 151 DS, US 152 DS and US 251 DS) have a CEE-Plug with phase inverter.

The sewage pumps are tested by the German Institute for Construction Engineering and correspond to the valid construction and test principles.

PERFORMANCE

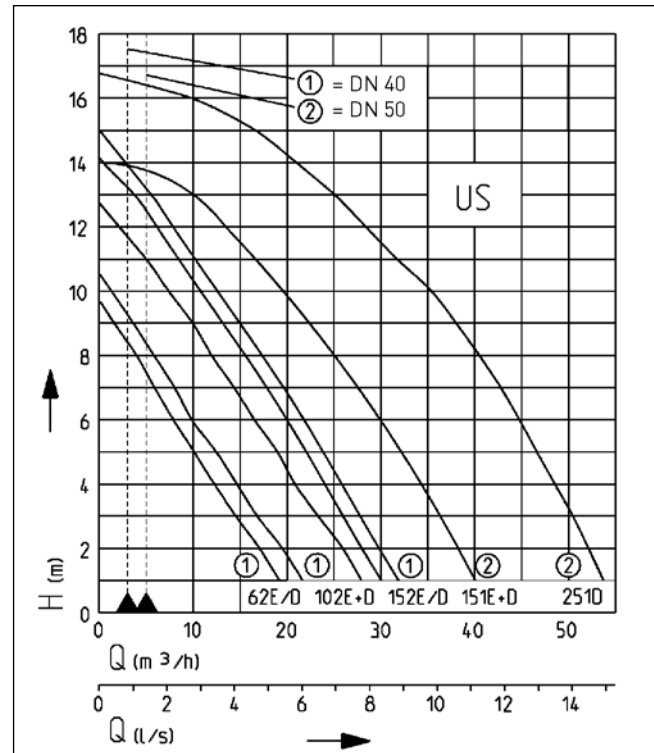

Type	Delivery head H [m]	1	2	3	4	5	6	7	8	9	10	11	12	13	14	16
US 62 E/ES	Flow rate Q [m³/h]	19	17	15	12	10	8	6	4	2						
US 62 D/DS		22	20	17	15	12	10	8	6	4						
US 102 E/D/ES/DS		28	26	23	21	19	17	15	12	10	8	5	2			
US 152 E/ES		30	29	27	24	22	20	18	15	13	11	8	6	3	1	
US 152 D/DS		31	30	28	26	23	21	19	17	14	12	10	8	5	3	
US 151 E/D/ES/DS		40	39	37	35	33	31	29	26	23	20	17	14			
US 251 D/DS		54	52	51	49	47	45	43	40	38	35	32	29	25	21	10

Specifications can be changed without notice. Performance subject to ISO 9906 tolerances.

The minimum flow velocity in the pressure piping must be 0.7 m/s according to EN 12056. This data is represented in the performance curve as a limit of application.

VDE/GS-Certification for US 62 E/ES, US 102 E/ES



US 62–US 251

SUBMERSIBLE DRAINAGE PUMPS

SCOPE OF SUPPLY

Pump according to DIN EN 12050 ready for connection with 10 m cable. US 62 and US 102 with safety plug (1-phase) or CEE-Plug (3-phase).

US 151, US 152 and 251: Pumps without level control with free lead end. Pump with built-in level control with CEE-Plug and phase inverter (3-phase) or safety-plug (1-phase).

MECHANICAL DATA

Pump	Vertical single-stage	Oil chamber	Yes
Free passage	10 mm	Seal on medium side	SiC mechanical seal
Bearing	Ball bearings, grease-lubricated	Run dry protection	Yes
Seal on motor side	Duplex rotary shaft seals	Submersible	Yes
		Pressure outlet	IG 1 1/2" (US151,251: 2")

ELECTRICAL DATA

Power line	10m H07RN-F	Insulation class	B (151,251:F)
Type of enclosure	IP 68	Winding thermostat	Yes

US 62–US 251

Type	Code No.	Voltage	Motor rating P1	P2	Current	Wires	Motor protection	Plug	Weight
Without level control									
US 62 E	JP09812	1/N/PE~230 V	0.83 kW	0.50 kW	3.9 A	3G1,0	Integrated	Safety	12.6 kg
US 62 D	JP09813	3/PE~400 V	0.85 kW	0.60 kW	1.4 A	4G1,0	Integrated	CEE	12.8 kg
US 102 E	JP09278	1/N/PE~230 V	1.37 kW	0.98 kW	6.0 A	3G1,0	Integrated	Safety	14.5 kg
US 102 D	JP00214	3/PE~400 V	1.36 kW	1.06 kW	2.4 A	4G1,0	Integrated	CEE	15.0 kg
US 152 E	JP09435	1/N/PE~230 V	1.60 kW	1.21 kW	7.5 A	3G1,0	on request ¹	Without	16.0 kg
US 152 D	JP09437	3/PE~400 V	1.70 kW	1.41 kW	3.1 A	4G1,0	on request ¹	Without	17.0 kg
With built-in level control									
US 62 ES	JP09814	1/N/PE~230 V	0.83 kW	0.50 kW	3.9 A	3G1,0	Integrated	Safety	12.7 kg
US 62 DS	JP09815	3/PE~400 V	0.85 kW	0.60 kW	1.4 A	4G1,0	Integrated	CEE	12.9 kg
US 102 ES	JP09279	1/N/PE~230 V	1.37 kW	0.98 kW	6.0 A	3G1,0	Integrated	Safety	14.5 kg
US 102 DS	JP00218	3/PE~400 V	1.36 kW	1.06 kW	2.4 A	4G1,0	Integrated	CEE	15.0 kg
US 152 ES	JP09436	1/N/PE~230 V	1.60 kW	1.21 kW	7.5 A	3G1,0	Integrated	Safety	16.0 kg
US 152 DS	JP09438	3/PE~400 V	1.70 kW	1.41 kW	3.1 A	4G1,0	Integrated	CEE	17.0 kg
Without level control									
US 151 E	JP09310	1/N/PE~230 V	1.68 kW	1.19 kW	7.6 A	4G1,0	on request ¹	Without	27.0 kg
US 151 D	JP09300	3/N/PE~400 V	1.60 kW	1.30 kW	3.0 A	6G1,5	on request ¹	Without	27.5 kg
US 251 D	JP09301	3/N/PE~400 V	2.60 kW	2.10 kW	4.4 A	6G1,5	on request ¹	Without	27.5 kg
With built-in level control									
US 151 ES	JP09241	1/N/PE~230 V	1.68 kW	1.19 kW	7.6 A	4G1,0	Integrated	Safety	29.0 kg
US 151 DS	JP09243	3/N/PE~400 V	1.60 kW	1.30 kW	3.0 A	6G1,5	Integrated	CEE	29.5 kg
US 251 DS	JP09245	3/N/PE~400 V	2.60 kW	2.10 kW	4.4 A	6G1,5	Integrated	CEE	29.5 kg

¹Protective motor plug necessary see accessory

US 62-US 251

SUBMERSIBLE DRAINAGE PUMPS

Dimensions and switching points US 62, US 102, US 152 (mm)

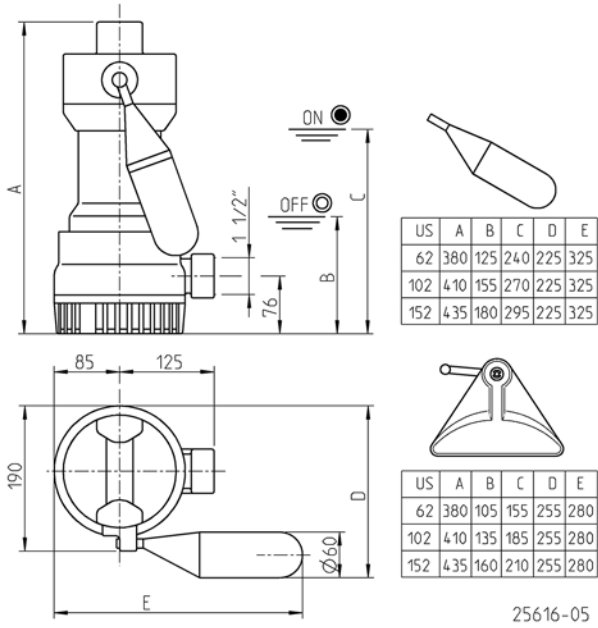

Dimensions US 151 and US 251 (mm)

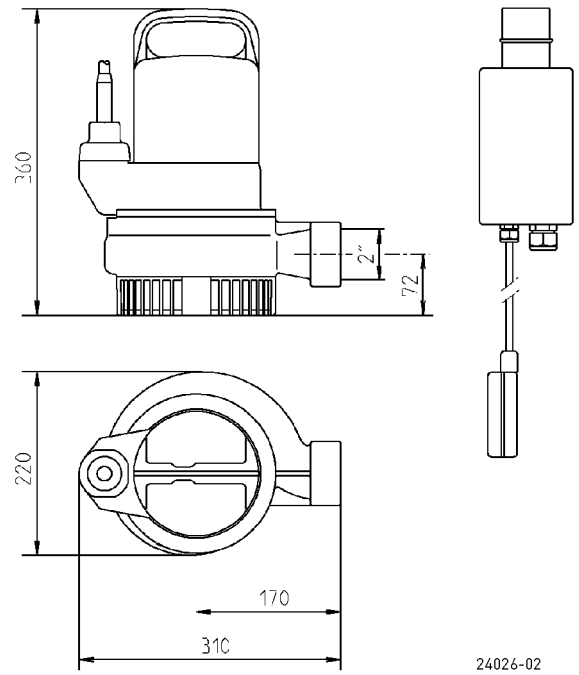

Dimensions and switching points GR 40 (mm)

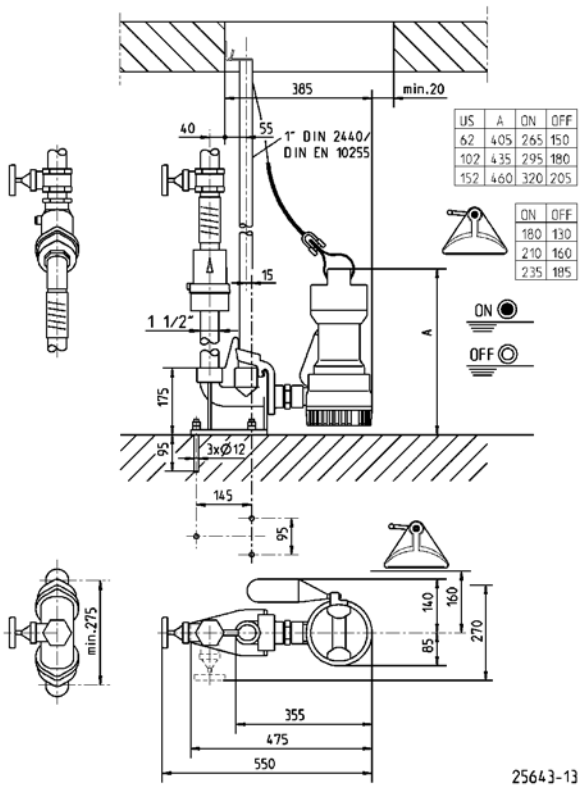

Dimensions GR 50 (mm)

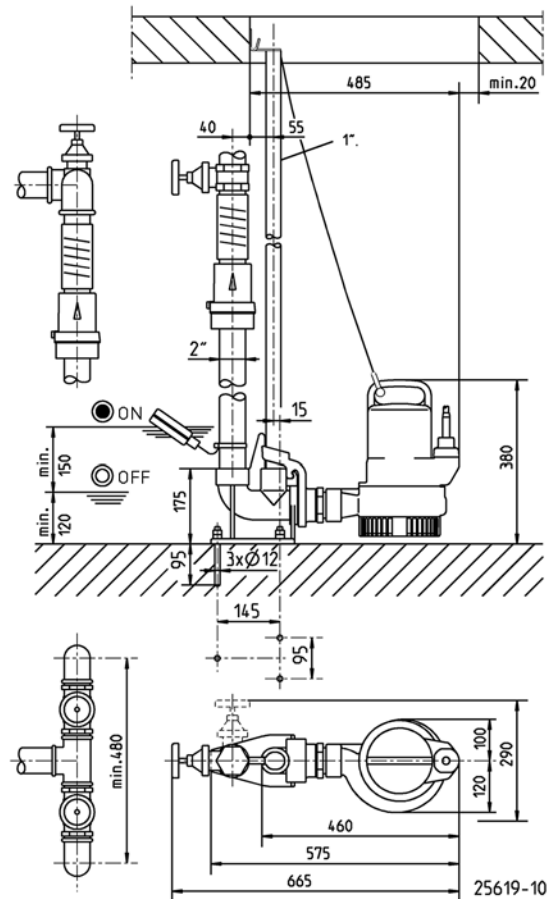

US 62-US 251

SUBMERSIBLE DRAINAGE PUMPS

Example of single pump installation with GR

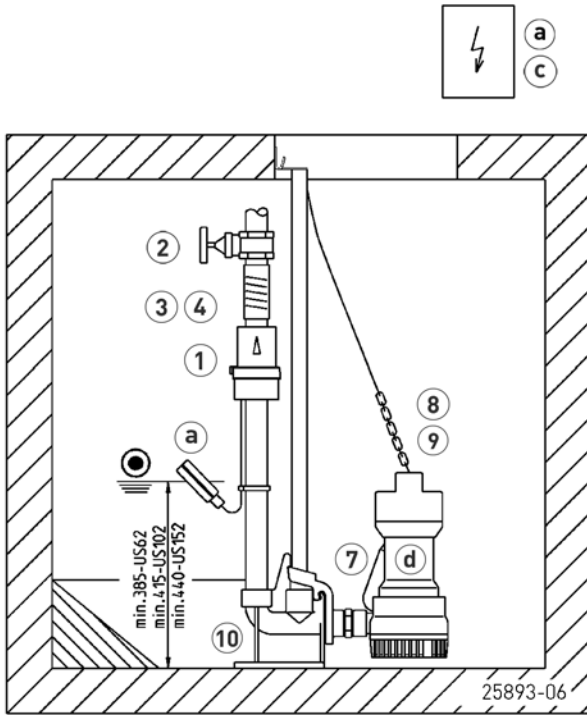

Single unit 1½" with GR 40: sump area min. 40x60 cm
 Single unit 1½" without GR: sump area min. 40x40 cm
 Single unit 2" with GR 50: sump area min. 40x70 cm
 Single unit 2" without GR: sump area min. 40x50 cm
 Duplex unit 1½" with GR 40: sump area min. 60x60 cm
 Duplex unit 1½" without GR: sump area min. 40x60 cm
 Duplex unit 2" with GR 50: sump area min. 70x70 cm

Example of duplex pump installation

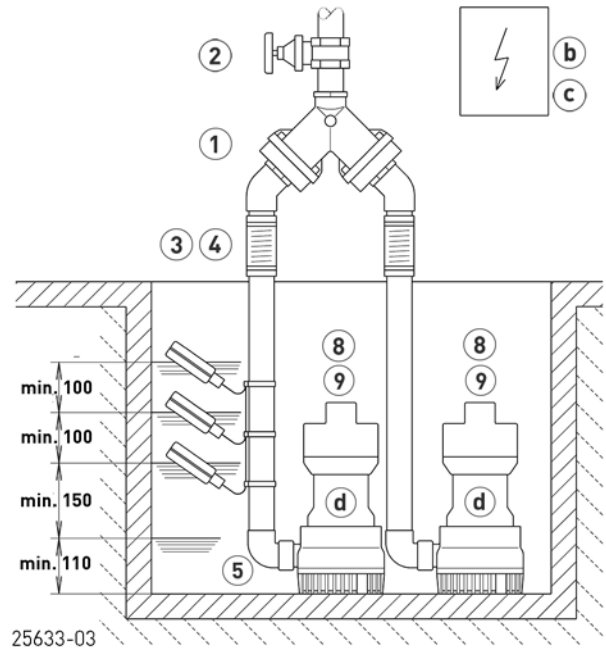

Duplex unit 2" without GR: sump area min. 50x70 cm

In case of installation beneath the backpressure level the pressure tube must be taken in a loop over the local backup level acc. to EN 12056. Besides, it must be secured with an EN 12050-4-proofed swing-type check valve. Additionally we recommend an alarm system.

In accordance with EN 12056-4 section 5.1, it has a built-in automatic spare pump or a double attachment included, which ensures that sewage drainage is not interrupted.

Suspend control unit in a dry room





MECHANICAL ACCESSORY

				Code No.
	1	Swing-type check valve		
		R40 EN 12050-4	1½" (DN 40), PN 4	150x120 (HxB) JP00317
		DR 40 EN 12050-4	1½" (DN 40), PN 4	200x280 (HxB) JP09155
		R50 EN 12050-4	2" (DN 50), PN 4	150x120 (HxB) JP00326
		Ball-type check valve		
		KE40 EN 12050-4	1½" (DN 40), PN 6	170x125 (HxB) JP47974
		K50 EN 12050-4	2" (DN 50), PN 6	185x155 (HxB) JP44782
	2	Stop valve		
			brass, 1½" (DN 40), PN 16	125x60 (HxB) JP44786
			brass, 2" (DN 50), PN 16	140x70 (HxB) JP44787
	3	Elastic connection		
			1½" (DN 40), PN 4	120x50 (HxD) JP44777
			2" (DN 50), PN 4	150x63 (HxD) JP44775
	4	Hose band clamp		
			1½"	JP44763
			2"	JP44764

US 62-US 251

SUBMERSIBLE DRAINAGE PUMPS

MECHANICAL ACCESSORY

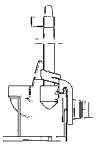
			Code No.	
	⑤ Elbow	1½"	JP45953	
		2"	JP44771	
	⑥ Hose coupling	Coupling Storz C	JP44770	
		Coupling Storz C	JP50217	
		Coupling wrench	JP25708	
		Pressure hose	12,5 m, synthetic, with coupling Storz C, Ø 38 mm	JP50298
		15 m, synthetic, with coupling Storz C, Ø 52 mm	JP00336	
	⑦ Special float	for lower switching points	JP44795	
	⑧ Chain	certified, 2.5 m, 320 kg, 5 rings (EN 818 mod.)	JP45901	
		certified, 5.0 m, 320 kg, 8 rings (EN 818 mod.)	JP45902	
		certified, 7.5 m, 320 kg, 11 rings (EN 818 mod.)	JP47365	
	⑨ Webbing	with shackle	JP45168	
	⑩ Guide rail system	GR 40	JP25592	
		GR 50	JP25593	
		Guide rail 1"	1500 mm	JP48937
		Guide rail 1"	2000 mm	JP48938
		Guide rail 1"	2500 mm	JP48939
		Guide rail 1"	3000 mm	JP48940



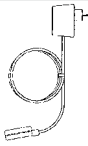

ELECTRICAL ACCESSORY

			Code No.	
	a Alarm unit	AG3	subm. ball contact switch, mains dependent, potential-free contact, 3 m cable	JP44891
		AG10	subm. ball contact switch, mains dependent, potential-free contact, 9.5 m cable	JP44892
		Washing machine stop		
		AW3	subm. ball contact switch, mains dependent, 3 m cable	JP44895
		AW0	for alarm forwarding in case of several washing machines	JP44899

US 62-US 251

SUBMERSIBLE DRAINAGE PUMPS

ELECTRICAL ACCESSORY

			Code No.
	b Control for duplex units		
	Control unit HIGHLOGO 2-00 E	230 V	JP47996
	Control unit BD 00 E	230 V, for pumps U3-U6, US 62-105, UV3, UV 300, 08/2 ME	JP45735
	Control unit HIGHLOGO 2-00	400 V	JP47997
	Control unit BD 00	400 V, for pumps U6, US 62-105, UV 300	JP45993
	Control unit HIGHLOGO 2-25	400 V	JP47998
	Control unit BD 25	400 V, for pumps US 151-155	JP45737
	Control unit BD 610 EC	230 V, with operating capacitor	JP45743
	Control unit HIGHLOGO 2-46	400 V	JP47999
	Control unit BD 46	400 V, for pumps US 251-253, UV 620-3, UV 625-3	JP45739
	Level control		
	Subm. switch pack B	3 subm. ball contact switch with 9.5 m and fixing devices	JP16725
	Subm. switch pack BmG	3 subm. ball contact switch with 9.5 m and counterweight	JP16726
	Protective motor plug		
	Safety protective motor plug	230 V, 8 A for pumps without integrated motor protection	JP40264
	Safety protective motor plug	230 V, 8 A for pumps without integrated motor protection	JP44753
	CEE-Motorprotection 2.9-4.0 A	400 V with level control	JP09725
	CEE motor protection 4.5-6.3 A	400 V with level control	JP09726
	CEE motor protection 2.9-4.0 A	400 V, mandatory for pumps without integrated motor protection	JP44750
	CEE motor protection 2.5-4.0 A	400 V, mandatory for pumps with integrated motor protection	JP44754
	CEE motor protection 4.5-6.3 A	400 V, mandatory for pumps without integrated motor protection	JP44751
	c Rechargeable battery	9 V, for mains independent alarm	JP44850
	d Seal leak detector	DKG	JP44900
	e Smart Home	FTJP radio transmitter	JP47209