

WCFIX PLUS

SEWAGE LIFTING STATION FOR WASTEWATER CONTAINING FAECES

- For pre-wall installation or fitting directly behind a floor-standing WC
- Powerful motor
- 19 mm free passage
- Runtime monitoring with acoustic alarm and potential-free alarm contact
- Vent valve and active carbon filter
- Maintenance friendly
- Integrated swing-type check valve



DESCRIPTION

The WCFix plus can be fitted in a pre-wall system or connected directly to a floor-standing toilet with a minimum flush volume of 6 litres. This allows an additional WC or an additional bathroom to be installed almost anywhere during renovation or alteration work. When installed below the backup level, the device also provides anti-flooding protection.

Pumping is particularly quiet due to its flow-optimized open centrifugal impeller. Due to this design, regular cleaning is not necessary and servicing works are significantly reduced.

Due to the restricted use, the installation is only permitted if the number of users is small and an additional WC above the backup level is available to them. According to EN 12050 Part 3, the following sanitary products can be connected:

- 1 WC
- 1 washbasin
- 1 shower
- 1 bidet

These are required to be located in the same room. According to EN 12050 Part 3, washing machines or bathtubs must not be connected.

The WCFix plus is equipped with a runtime monitoring for early acoustic fault signalling. It is also possible to pass on the fault signal to other places via a volt free contact fitted as standard. The appliance is fully pre-assembled, ready for connection to a power socket, and operates fully automatically as soon as the flush is actuated. When installed in bathrooms or shower rooms, the corresponding German VDE regulations must be observed.

Attention: Do not flush any hygienic products down the toilet, because they can cause malfunctions!

For the installation and and for maintenance work a sufficiently large inspection opening has to be planned (accessory).

PERFORMANCE

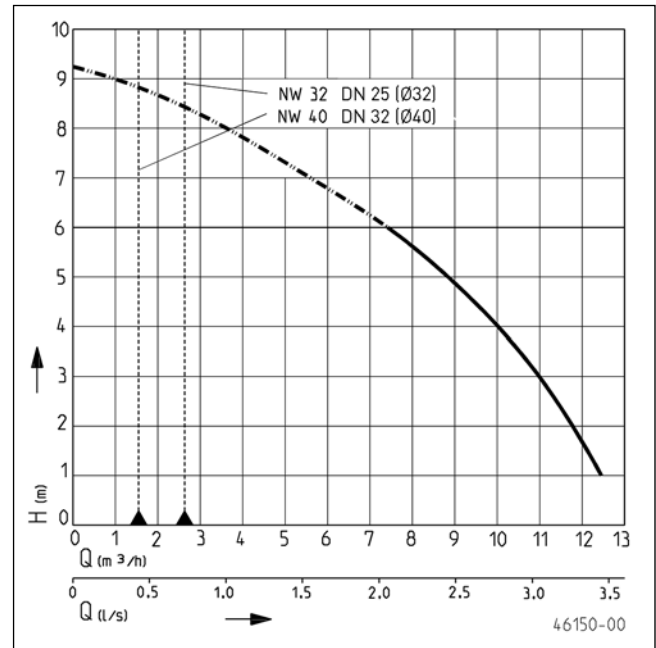

Type	Delivery head H [m]	1	2	3	4	5	6
WCFIX Plus	Flow rate Q [l/min]	208	196	183	163	146	125

Specifications can be changed without notice. Performance subject to ISO 9906 tolerances. The minimum flow velocity in the pressure piping must be 0.7 m/s according to EN 12056. This data is represented in the performance curve as a limit of application.



WCFIX PLUS

SEWAGE LIFTING STATION FOR WASTEWATER CONTAINING FAECES

SCOPE OF SUPPLY

Appliance including pump complied with EN 12050, ready to connect with cable and plug, complete with collars, outlet elbow,

swing-type check valve 1¼", ventilation insert, active carbon filter, clamps and fixing materials for buoyancy control.

MECHANICAL DATA

Seal on motor side	Rotary shaft seal	Impeller	Vortex impeller, GFK
Oil chamber	Yes	Motor housing	Stainless steel
Seal on medium side	Rotary shaft seal	Pump housing	GRP
Shaft	Stainless steel	Weight	6.2 kg

ELECTRICAL DATA

Voltage	1/N/PE~230 V	Type of enclosure	IP 44
Motor rating P1	0.73 kW	Motor protection	Installed in the winding
Motor rating P2	0.47 kW	Plug	Safety
Current	3.2 A	S3	30 %

WCFIX PLUS

Type	Code No.
WCFIX Plus	JP45367

Dimensions (mm)

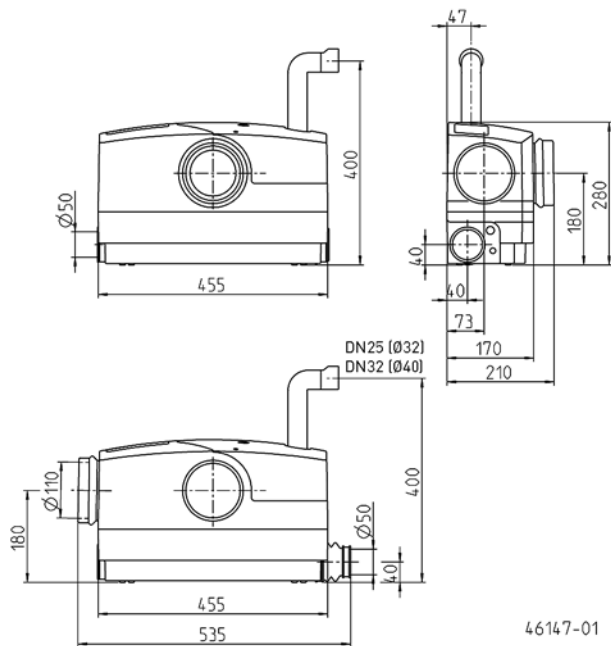

Performance

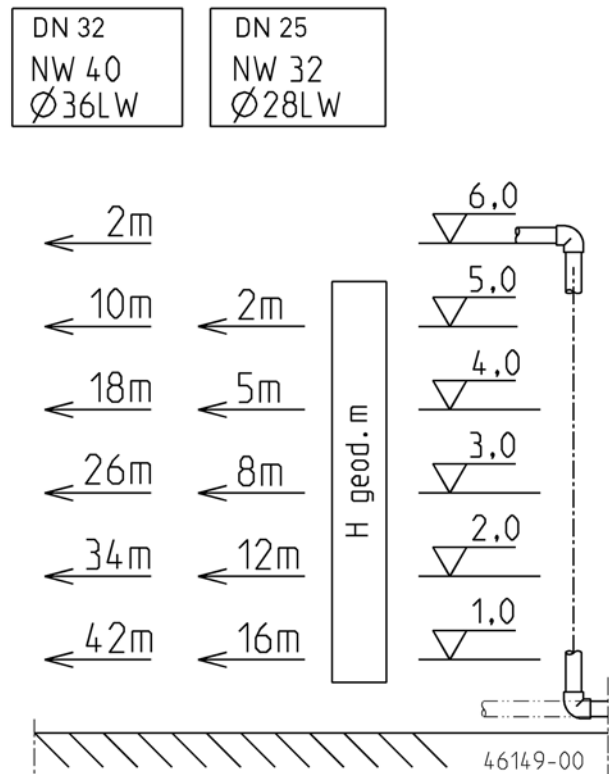

WCFIX PLUS

Example of installation

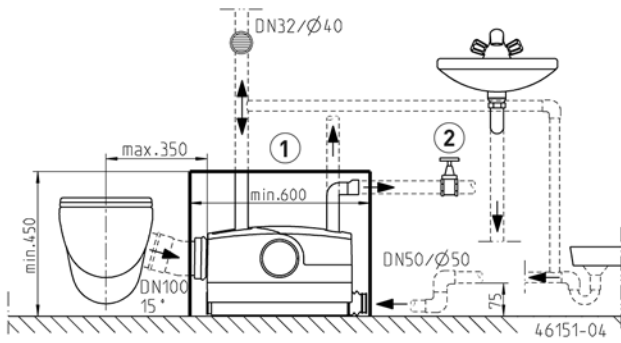

Example of installation

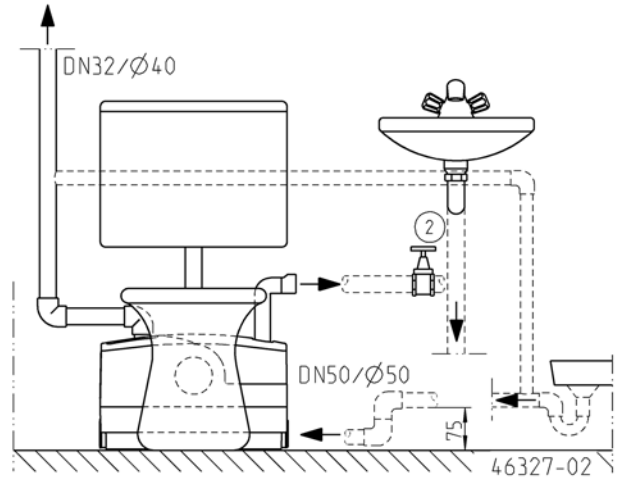

MECHANICAL ACCESSORY

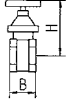
			Code No.
	1 Installation kit	selectable size according to the tiles	JP41075
	2 Stop valve	1/4" (DN 32), PN 16	110x60 (HxB)